

Packaging - Processing Bid on Equipment

1-847-683-7720

www.bid-on-equipment.com

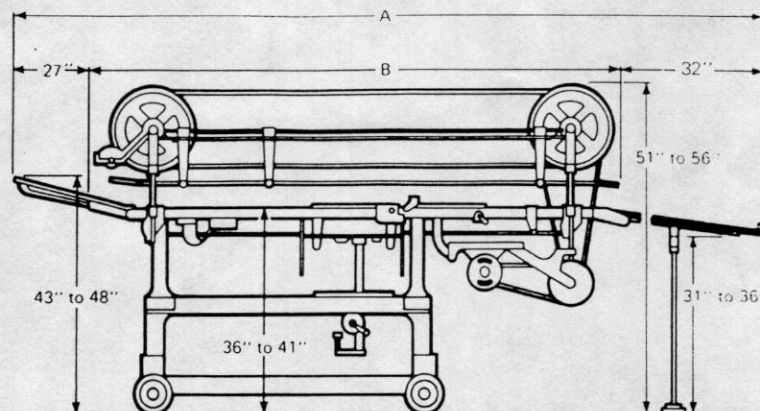
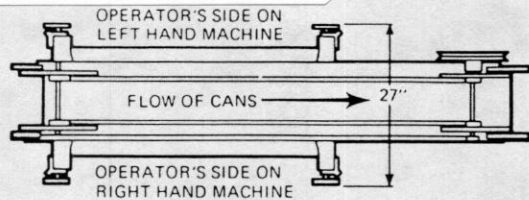

Machines with standard label stack height

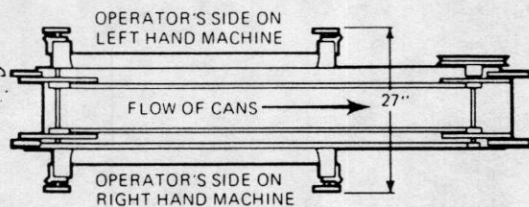

SERIES	404	611
DIMENSIONS	A 136"	A 176"
	B 77"	B 117"

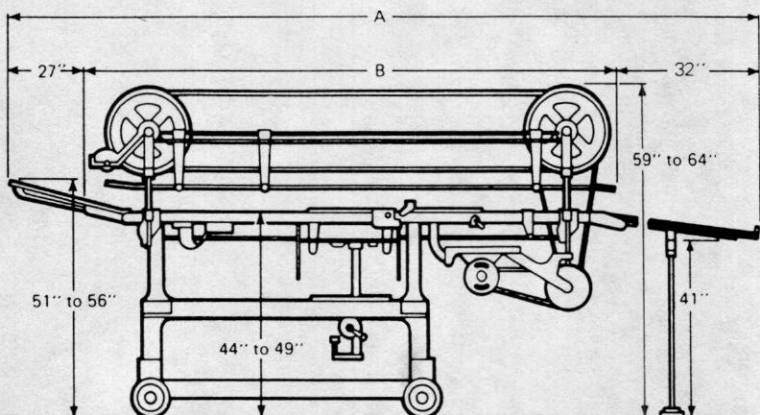

Machines with extra capacity high label stack

General Specifications

	611 Machines	404 Machines
Main Drive Motor	¾ h.p. 230/3 phase/60 cycle	¾ h.p. 230/3 phase/60 cycle
Glue Pot Thermostatic Control Range	150° F. to 500° F.	150° F. to 500° F.
Machine Weight	1300 lbs.	1100 lbs.
Control Power	230/single phase/60 cycle	230/single phase/60 cycle
Shipping Weight	1900 lbs.	1725 lbs.
Label Lap	Specify right or left hand	Specify right or left hand

Machine Speeds: Up to 600 per minute on cans, up to 400 per minute on fiber, up to 300 per minute on glass, up to 200 per minute on plastic.

Cast iron wheels standard on all machines.
Manual motor starter standard on all machines.
Right or left hand machines available.

Two label tables supplied with each machine except aerosol machines where three are provided.

Options

Explosion-proof models	Work lights
Elevated can return tracks	Dual glue pots
Infeed elevators	Voltage as required
Infeed and discharge twisters	

Represented

MATEER-BURT CO.

436 Devon Park Drive • P.O. Box 405 • Wayne, Pa. • 19087 • U.S.A.

BERWIND
Process Industries Group

(215) 293-0100

Telex: 83-1612

Packaging - Processing Bid on Equipment

1-847-683-7720

www.bid-on-equipment.com