

**INSTALLATION
OPERATION
MAINTENANCE**

**Wet Scrubbers
MW-100, MW-200, MW-300**

**DO NOT STORE GRAY PVC
SCRUBBERS IN DIRECT SUNLIGHT**

Built to Last



**MW-100 FUME
SCRUBBER**



**MW-300 FUME
SCRUBBER**



**MW-200 FUME
SCRUBBER**

PO Box 5319
281 Hughes Drive
Traverse City, MI 49686

Ph: 231-941-5865
Fax: 231-941-1636
mapco@midwestair.com

JOB NO: _____

CUSTOMER: _____

APPLICATION: _____

MAPCO
MIDWEST AIR PRODUCTS CO., INC.

**Packaging - Processing
Bid on Equipment**
1-847-854-8577
www.bid-on-equipment.com

INDEX

Cautions	3
Introduction	4
Safety	
Receiving and Inspection	
Handling and Storage	
Foundation	
Duct Connections	
General	
Materials of Construction	
Operating Temperature	5
Installation	
Supply Piping	
Waste Piping	
Fresh Water Make-up	
Blowdown System	6
Remote Recirculation	
Self-Contained Recirculation	
Pump	7
Operating Data	
Pre-Start-up Checklist	
Maintenance Instructions	8
Inspection Doors	
Strainers	
Pumps/Motors	
Spray Nozzles	
Mist Eliminator	
Photohelic Gauge	9
pH Control System	9
Trouble Shooting	10
MW-100 Parts	11
MW-200 Parts	12
MW-300 Parts	13
Scrubber Weights	14

CAUTION

This equipment can cause serious bodily injury. Severe damage could occur to the equipment, surrounding property and automobiles. Before operating this equipment read the Installation, Operation and Maintenance Instructions.

1. Do not operate fan without scrubber recirculation system on.
2. Do not operate fan or scrubber when spray nozzles are plugged.
3. Do not operate fan if scrubber recirculation liquor is concentrated. Proper fresh water make-up and blowdown rates must be maintained.
4. Spray pattern should be adjusted so spray does not hit scrubber side wall.
5. Do not cover plating tanks when heat is on or until tank solution is ambient temperature.
6. If fan and scrubber have been shut down for any period of time, scrubber recirculation system should be run while fan is off to clean scrubber internals.
7. If unit is equipped with a sump heater and freezing conditions exist, recirculation pump and heater should be in operation during periods of shut down unless scrubber sump is completely drained.
8. Improper pH setting could cause severe damage (see section on **pH control**).
9. Velocity/CFM - make sure exhaust fan is exhausting proper CFM. Higher CFM than design could cause excessive misting at the scrubber outlet.

Any of the above could result in corrosive fumes passing through the scrubber and impinging on the scrubber packing and mist eliminator. Corrosive condensate in the duct and exhaust stack could be discharged from the stack. Any apparent malfunction of the fume scrubber should be reported to MAPCO for repair or service instructions.

Start-Up Service:

In addition to this installation, operation and maintenance manual, MAPCO offers a factory trained service representative to perform, assist or advise in the installation and start-up of this equipment. The cost for this service is charged per man at the following rates:

- | | |
|---|--------------|
| A. First eight (8) hours of a single day | \$50.00/hour |
| B. Overtime hours in a single day | \$65.00/hour |
| C. Sunday or Holiday | \$80.00/hour |
| D. Other expenses such as airfare, hotel, car rental, meals, parts, tax, freight, etc. if applicable will be charged at cost plus 15% administration fee. | |
| E. Company Vehicles | |
| 1. Company car or truck @ \$1.00/mile | |
| 2. Company truck and trailer @ \$1.50/mile | |

Note: MAPCO assumes the "End User" is knowledgeable of this equipment and fully understands the risks associated with the installation, operation and maintenance of the equipment purchased.

MAPCO SCRUBBER MODELS MW-100, MW-200 and MW-300

INTRODUCTION - The performance of every MAPCO scrubber depends on many factors. The purpose of this manual is to make you aware of these factors so you will obtain the utmost efficient and dependable performance from your MAPCO equipment.

Providing care is exercised in installing this equipment, and it is given reasonable maintenance, you can be assured of trouble free operation for years to come.

It is important that you study this manual prior to installing and operating this equipment to assure safe installation and operation.

SAFETY - The very nature of air handling equipment and accessories present a hazard to personnel during installation and maintenance. The following precautions should be observed prior to starting and maintaining the scrubber:

1. All system motors should be locked out. This is accomplished by padlocking the disconnect switch in the off position until installation or maintenance is complete.
2. The scrubber housing should be inspected for debris or any loose parts.
3. Installation should be complete with inlet and outlet accessories attached.
4. All guards should be in place and secured. Never remove or replace any guards unless pump is shut-down and locked out.
5. All dampers in duct system should be locked in open position.
6. Never discharge corrosive or harmful fumes from the fan. Fume Scrubber should always be operated with the proper amount of fresh water make-up.
7. Inspect ductwork for leakage of harmful or corrosive fumes.
8. Follow good safety practices when installing or maintaining this equipment.

RECEIVING AND INSPECTION - Upon receipt of shipment, check first to see that all items on bill of lading and/or packing slip have been received. By careful inspection determine whether damage has occurred in transit. Any shortage or damage should be noted and a claim should be filed immediately.

HANDLING AND STORAGE - If installation of the scrubber is delayed and storage is made outdoors, provide reasonable weather protection. Special attention should be given to pump and motor to prevent the entrance of water. When transporting or installing a scrubber, the lifting eyes should be used to prevent damage. Never pick a scrubber up by its flanges. Do not tarp equipment or ductwork exposed to direct sun-light. Excessive heat can build-up causing distortion. Motors and pumps supplied with products manufactured by Midwest Air Products Co., Inc. have been test run prior to shipping. All scrubbers have been test run and checked for leaks.

FOUNDATIONS - A rigid, level foundation is vitally essential for operation and good performance of a scrubber. A frequent error is to design a foundation for the weight of the scrubber only. Consideration should be given for weight of the scrubbing liquor.

Poured concrete is preferred to steel or wood. Steel platforms should be heavily braced.

DUCT CONNECTIONS - Duct loads can cause distortion with consequent damage to the scrubber. With this in mind, please observe the following:

1. Support ducts independently of scrubber.
2. Use flexible connections between fan and scrubber.
3. Inlet duct should be supplied with a flanged connection a minimum of 3'-0" from scrubber inlet.

GENERAL

1. Prior to installing this equipment inspect the name plates or other tags for special instructions.
2. It is recommended that this equipment be installed by personnel familiar with the installation of this type of equipment.
3. All MAPCO Fume Scrubbers are supplied with an enamel coated steel base. If the scrubber is mounted on a platform, it should be thoroughly braced. If the scrubber is roof mounted, a structural engineer should be consulted to determine if the roof can support the operating weight of the scrubber (See operating weights on page 26). This equipment is constructed of P.V.C., Polypropylene or F.R.P. Care should be exercised in handling this equipment during installation to prevent damage caused by external stress or shock.

OPERATING TEMPERATURES - P.V.C. Scrubbers should not be used on constant temperatures exceeding 130° F. Polypropylene should not be used on temperatures exceeding 160° F. and F.R.P. Scrubbers should not be used on constant temperatures exceeding 180° F.

INSTALLATION INSTRUCTIONS

1. Prior to installation, inspect packing material to determine if damage or settling has occurred during shipment. Inspection can be made by looking at the packing face from scrubber inlet side. Vertical units can be viewed from the inspection door.
2. Inspect the mist eliminator section which can be viewed from the outlet end. Check the mist eliminator for any shifting or damage during shipment. Vertical units can be viewed from the top prior to mounting top section.
3. Inspect all piping for breakage.
4. All MAPCO scrubbers are equipped with lifting eyes for rigging. Do not lift P.V.C. scrubbers by the flanges.
5. It is recommended that inlet/outlet transitions be bolted on prior to setting the scrubber. Prior to bolting transitions be sure the flanges are clean. Use adhesive backed, closed cell gasket or 100% silicone caulking material supplied with the scrubber. Apply gasket starting at the center of the top flange horizontally. Continue around face of flange to starting point making sure gasket is within the inside of bolt holes. Bolt transitions in place using stainless steel hardware supplied with unit. Bolt holes (if not drilled) should be on 4" or 6" centerlines.
6. After transitions are installed and bolts tightened, working inside the scrubber, apply a sufficient amount of compatible caulking along the bottom at the flange joint and approximately 2'-0" up both sides of inlet and outlet. This method applies for transitions bolted in the horizontal position. Using a putty knife, smooth out the caulking to be sure the joint is completely sealed. This is a precautionary step only. Mapco scrubbers are supplied with 3/4" thick inlet and outlet flanges to promote a good seal and minimize leakage.
7. The scrubber packed bed, scrubber body, mist eliminator, and transitions should be thoroughly cleaned with a hose spray nozzle to wash any foreign material out of scrubber sump prior to connecting drain piping. Debris can cause pump malfunction.

SUPPLY PIPING - Supply piping will have to be installed from pump discharge to scrubber spray header connection on remote units only. Self contained units and the remote tank require a fresh water line to the make-up valve (see fresh water make-up page 4). Remote scrubbers are supplied with a pump and motor

mounted on a polyethylene tank. Starting at the scrubber, use the same diameter piping as the spray header connection on the scrubber. Continue with this diameter down to pump discharge. In most cases the diameter will reduce down at the pump discharge. A gate valve and strainer are supplied with both self-contained and remote units, normally at the pump discharge. The gate valve allows more precise control over the spray pattern while allowing the valve to close should the pump need repair or change out. The strainer minimizes nozzle plugging. All horizontal runs of piping should be sloped towards the remote tank to avoid freezing conditions in cold climates.

In certain cases, scrubbers equipped with mesh pad mist eliminators may include a washdown spray header connection. A fresh water supply line capable of delivering the specified liquid flow rate will need to be plumbed to this connection. The washdown will be periodic with the exhaust fan turned off. Under no condition should the washdown schedule be deviated from that which is suggested by MAPCO without prior authorization from MAPCO.

WASTE PIPING - Self contained scrubbers are supplied with overflow and drain connection. Install a valve immediately after the drain fitting. Plumb the overflow into a tee after the valve on the drain.

Remote scrubbers are supplied with a drain. Using the same diameter piping as the drain fitting, run the drain line down to remote tank. Connect drain line to the fitting supplied on top of recirculation tank. Do not reduce the drain line diameter from that of the scrubber. An overflow and drain connection are supplied on the side of the remote tank. Connect the same as instructed above for the self-contained unit. Scrubbers with mesh pad mist eliminators have a drain fitting located directly underneath the mesh pad near the outlet of the scrubber. This will require a drain trap of the same diameter as the drain. Plumb this drain to the scrubber overflow/drain. If the fan is equipped with a drain fitting, plumb in the same manner as the mist eliminator.

FRESH WATER MAKE-UP - Fresh water must be continuously supplied to scrubber to maintain overflow of contaminated sump water. Overflow rate should be maintained at 3% - 5% of scrubber recirculation rate.

Example: Scrubber recirculation rate 30 GPM, then overflow rate is 3% of 30 GPM or 0.90 GPM.

NOTE:

Float valves should not be used in place of make-up control. They should be used for control of evaporation only.

For more precise water usage, see section titled "Blowdown".

- A. Self contained scrubbers and remote tanks are supplied with a flowmeter for regulating make-up water. A water supply line capable of delivering the proper GPM as indicated on scrubber nameplate is also supplied. At a convenient location, install a shut off valve prior to connecting to flow meter. Check with local codes concerning installation of back-flow valve.

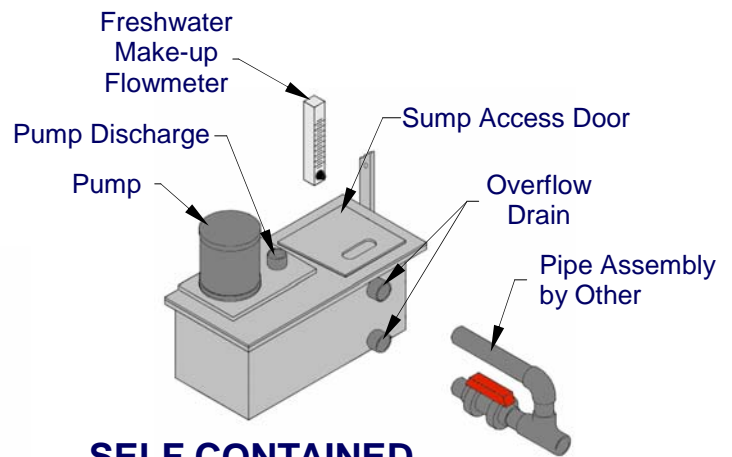

SELF CONTAINED

PUMPS - Depending on the recirculation package purchased with your scrubber, most units are supplied with a CPVC, seal-less, vertical pump located on the scrubber sump or remote tank. Standard pumps are less a mechanical and operate at 3600 RPM. CPVC pumps can run dry for short periods without causing damage to pump.

WARNING: Check pump rotation before filling the sump and final wiring. Some manufacturers recommend that impeller be removed prior to bump starting. Read the instructions, reverse rotation can cause severe damage. Impeller should rotate CW when viewed from the motor end (see pump label).

PUMP MOTORS-Single Phase - Single phase pumps are supplied with dual voltage motors (115/230). Follow wiring instructions on motor nameplate. Make sure pump is wired for clockwise rotation as viewed from motor end.

PUMP MOTORS-Three Phase - Three phase pumps are supplied with dual voltage (230/460). Follow wiring instructions on motor nameplate.

1. After motor is wired, bump start motor.
2. Check motor to determine rotation.
3. If rotation is CCW when viewed from motor end, interchange any two leads for correct rotation.

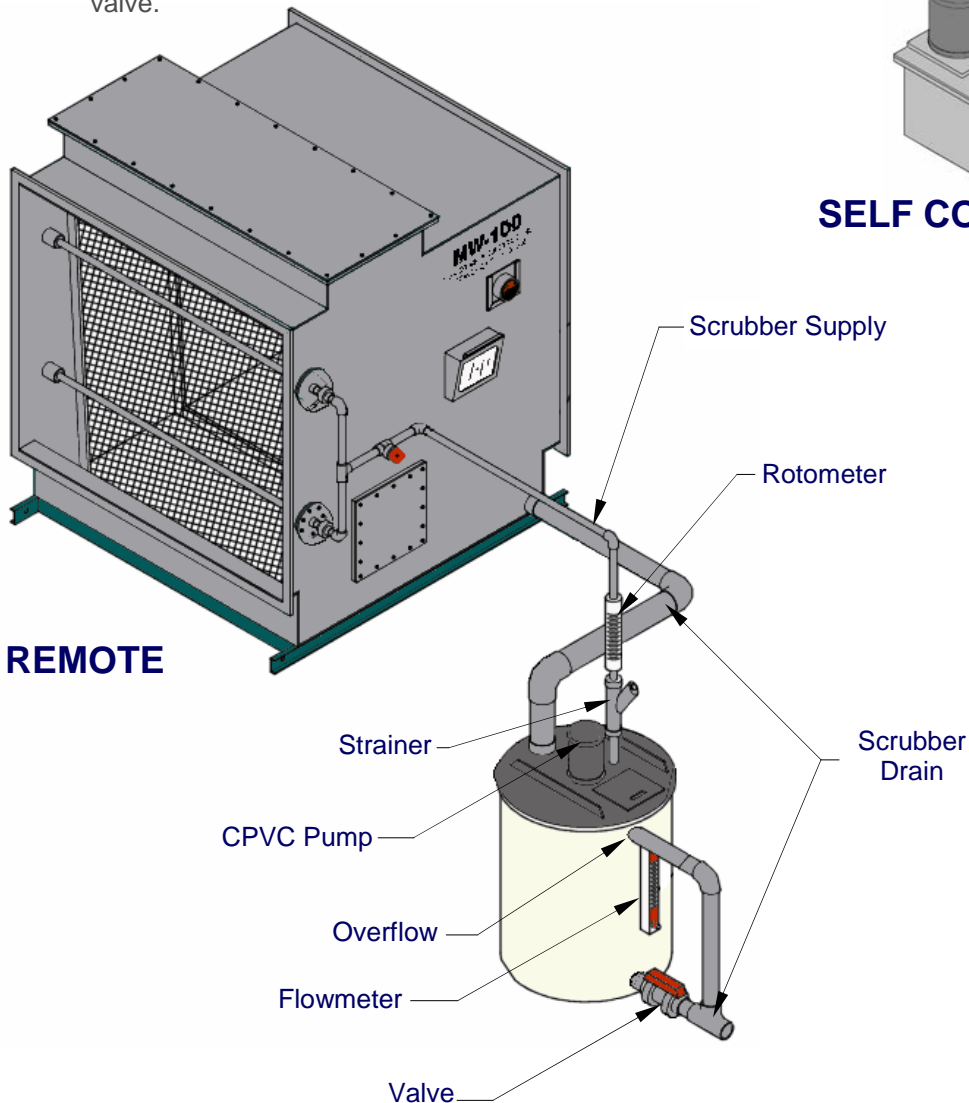

REMOTE

- B. Prior to starting the system, check all valves for proper position and leaks. Regulate gate valve so spray pattern is adequate to cover pack area while minimizing spray on scrubber side walls. The drain valve should be perpendicular to line of flow.

OPTIONAL BLOW-DOWN SYSTEM

Scrubbers can be purchased with a manual or automatic blow-down system. This system will conserve water and minimize effluent. The scrubber liquor should be monitored weekly for concentration. After a few weeks of monitoring during normal operation, a schedule can be devised to blow-down a portion or all of the scrubber liquor. After or during blow-down, fresh water can be introduced into the system. Consult Mapco for specific details or price quotes.

OPERATING DATA - The nature of this equipment is such that a record of operating data should be maintained to ensure proper maintenance and to simplify troubleshooting. Depending on the application it may be necessary to inspect the system on a weekly basis. In any case the maximum interval should be no more than one month. The responsible party should inspect and record the following:

1. Freshwater make-up setting.
2. Overflow valve in open position.
3. Air flow rate (velometer).
4. Spray Pattern.
5. Nozzles for plugging.
6. Strainer for plugging.
7. Packing for sludge build-up
8. Mist eliminator for plugging or build-up.
9. Mesh pad for plugging or saturation.
10. Record date and time of observations.

PRE-START-UP CHECKLIST - Prior to starting the system the following should be inspected:

1. Correct fan rotation.
2. Fan and pump motor wired for correct voltage.
3. Fan accessories installed.
4. All dampers locked in open position.
5. Ductwork clean and free of debris.
6. Ductwork sealed properly.
7. Plumbing connections leak tested.
8. Freshwater make-up set correctly.
9. Overflow and drain connected.
10. Packing and mist eliminator installed properly.
11. Correct spray pattern.

SYSTEM START-UP AND OPERATION

It is critical that the scrubber system be started and checked out prior to filling plating tanks. A scrubber over-load condition is possible when mixing volatile chemicals at the plating tank due to excess misting or violent Reaction of strong chemicals.

1. Fill scrubber sump or remote tank with freshwater until water begins to overflow.
2. Set freshwater make-up valve to proper GPM.
3. Start pump and then pump.
4. Adjust spray pattern to minimize spray hitting side wall of scrubber.
5. Immediately check stack discharge. If excessive misting is observed shut system down immediately and consult factory.
6. Adjust riser dampers to produce desired flow rate. Begin at riser furthest from exhaust fan and work towards fan. Measure velocity with pitot tube and average readings. Velocity (**FPM**) X Area of riser (dia X dia X.7854 divided by 144= ft² area)= **CFM**.

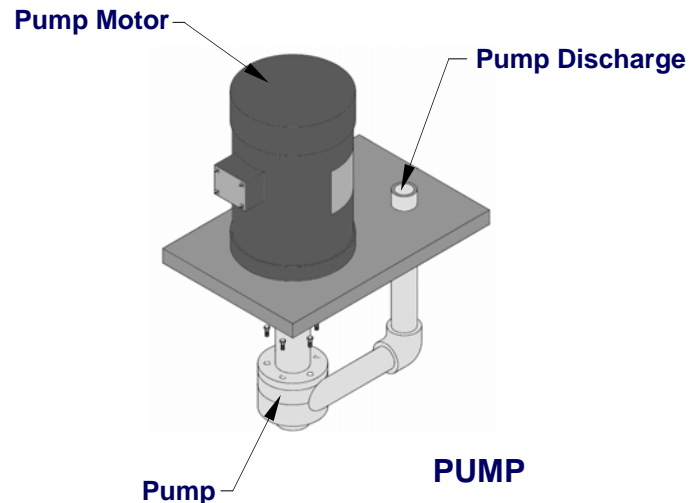

MAINTENANCE INSTRUCTIONS - The scrubber should be checked weekly for the first couple of weeks until a comfort level is established. The nature of the contaminant being scrubbed and proper maintenance procedures will determine the frequency of inspection. It is important that the pump, spray nozzles and filter media be properly maintained in order for the scrubber to achieve maximum efficiencies.

INSPECTION DOORS - P.V.C. inspection doors are installed at critical points on the scrubber. Bolt-on doors are installed at key points to facilitate cleaning of the vessel.

STRAINER - Clean in-line strainers once a week until a schedule can be established.

PUMPS - Recirculation pumps, if properly maintained, seldom require maintenance. Should it be necessary to remove a pump, please observe the following:

1. Turn off and lock out power to the pump.
2. Disconnect pump wiring.
3. Shut off diaphragm valve on pump discharge. If scrubber is not equipped with shut off valves, drain sump prior to removing pump.
4. Remove bolts on pump mounting plate and pull pump.
5. After repairs or installation of new pump, remember to turn valves to original position.

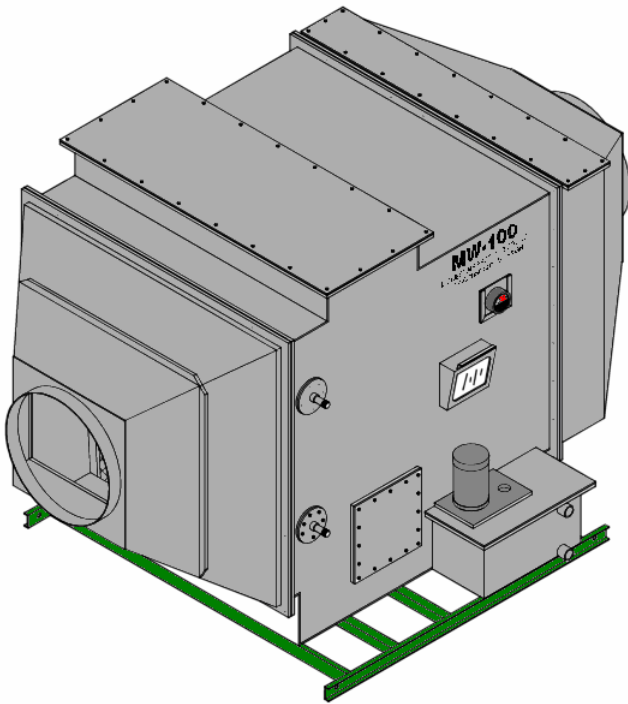

PUMP MOTOR - Remember a clean motor runs cooler. The motor should be cleaned and inspected at regular intervals. At this time, bearings should be checked for wear and greased if applicable.

PACKING ACCESS - MAPCO fume scrubbers are equipped with bolt-on doors for (1) pack removal and (2) pack fill. MW-100 scrubbers have a door on top of unit to insert new packing. The scrubber should always be shut down when removing the packing. Scrubbers not equipped with a top door can be filled by leaving the fan on and inserting packing through pack fill door on side of scrubber. Should the packing become plugged, it can sometimes be cleaned with a high pressure water hose. Do not use steam or high temperature water.

SPRAY NOZZLES - All Mapco scrubbers are supplied with removable spray headers from outside the unit. Spray headers are bolted in place using 1/4-20 stainless steel bolts with teflon gasket or 100% silicone caulk. Each header is equipped with a backing plate with 1/4" stainless steel nuts pressed in place. The backing plate is then welded to the scrubber side wall thereby encapsulating the stainless steel nuts. This eliminates the possibility of stripping out PVC threads so common with other units.

SPRAY PATTERN - Spray pattern is critical to the performance of your wet scrubber. All Mapco scrubbers are equipped with a gate valve for better control of the spray pattern. Observe spray pattern at start-up and adjust nozzle pattern to minimize water droplets colliding with side wall of scrubber. Make sure spray nozzles are pointed towards the packing.

NOZZLE AND HEADER CLEANING - Periodically check nozzles for plugging. If spray nozzles become plugged, remove and clean as follows:

- A. Shut pump down and lock out disconnect switch.
- B. Drain all plumbing lines of scrubbing liquor.
- C. Remove each individual spray header.
- D. Remove all nozzles from header and clean.
- E. Remove threaded cap on opposite end of spray header and flush out header with clean water.
- F. Reverse above steps to re-install. If plugging was caused by chemical build-up, adjust scrubbing liquor pH.

CHEVRON MIST ELIMINATOR - Mapco scrubbers utilize a fixed chevron type PVC mist eliminator (providing four (4) 30° directional changes in air flow) for removal of large droplets. Removable chevron mist eliminators are optional.

Inspect the mist eliminator periodically for plugging, broken pieces or shifting.

NOTE: If the eliminator is broken it must be replaced.

MESH PAD MIST ELIMINATORS - Mesh pad mist eliminators fabricated with multiple filament diameters offer a greater degree of mist elimination on smaller mist particles. Mesh pad mist eliminators are standard and used in conjunction with a chevron eliminator, the mesh eliminator is supplied in a removable configurations. Due to the density of the mesh pad, the scrubber will operate under a higher negative pressure than normal.

MESH PAD MAINTENANCE - Under normal operation with proper scrubber maintenance, the mesh eliminator requires little or no maintenance (see trouble shooting chart). If the mesh pad becomes plugged it can be cleaned as follows:

CLEANING PAD

1. Remove pad from scrubber and clean pad with pressurized water hose. If pad cannot be removed, clean through the cleanout door.
2. Clean pad chemically

CAUTION: Follow proper safety precautions while cleaning pad. Wear protective clothing and safety goggles.

PHOTOHELIC GAUGE (optional) - Inspect photohelic gauge periodically. An increase or decrease in static pressure indicates a problem. See trouble shooting chart.

NOTE: Severe negative pressure in building can cause a change in static pressure.

INSTALLATION & MAINTENANCE-pH CONTROL SYSTEM (OPTIONAL)

All MAPCO scrubbers utilize water as the main scrubbing agent. In certain cases, contaminants which are low in solubility require the addition of chemical additives to improve absorption. This is accomplished by the addition of a pH control system to monitor and adjust the scrubbing liquid when necessary.

When using a pH control system it is necessary to maintain a slight blow-down from scrubber sump or incorporate a manual or automatic blow-down system. This will insure that salts do not build-up in sump or plug the spray nozzles and mist eliminator.

The panel is mounted on the scrubber unless otherwise specified. When wired properly, the pH controller signals the chemical feed pump when to pump neutralizing agent from holding tank to the scrubber recirculation reservoir.

WARNING:

1. pH probe sensor will dry out if not in solution for extended periods of time. If this is allowed the controller cannot be programmed.
2. Depending on the chemicals involved, the pH probe may have to be replaced on a regular basis. It is recommended that back-up probes are maintained.

WIRING - See instructions supplied with unit (115 volt single phase power).

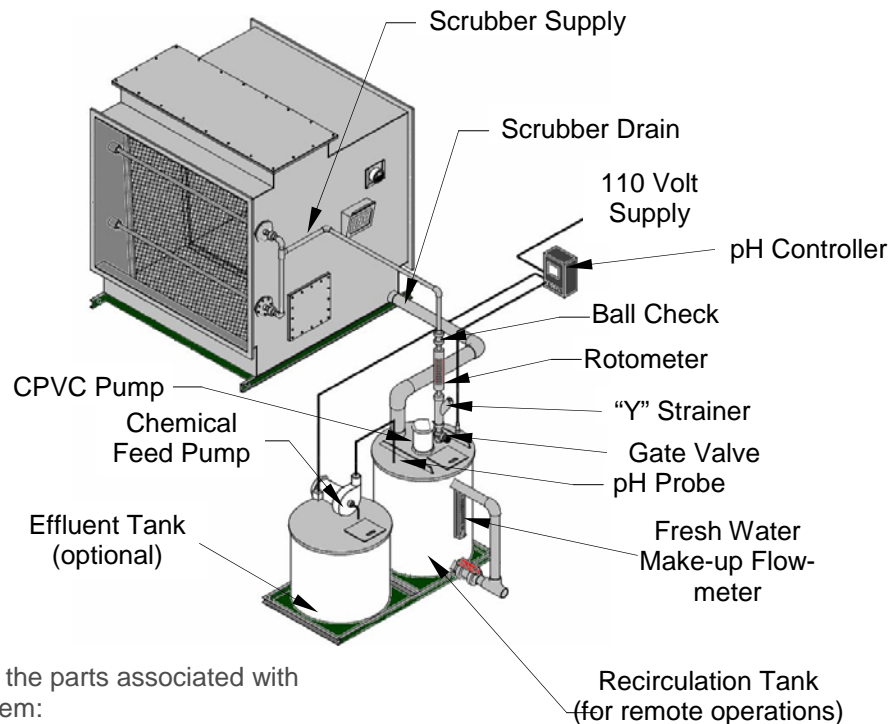

The following list describes all the parts associated with a standard chemical feed system:

1. PVC or Polyethylene holding tank with overflow and drain.
2. Chemical feed pump mounted on tank with pump suction pre-plumbed. The outlet plumbing must be supplied and installed by other.

NOTE: If holding tank was not purchased with scrubber, chemical feed pump will be supplied loose.

3. Mixer (optional).
4. pH Controller mounted in a NEMA box with pH probe.

SCRUBBER TROUBLE SHOOTING

PROBLEM	POSSIBLE CAUSE
POOR SPRAY PATTERN	<ul style="list-style-type: none"> • Spray Nozzles plugged up • Spray Headers plugged up • Pump suction blocked • Pump discharge piping too small • Insufficient water in sump • Pump running backwards • Total head exceeds that of pump
UNIT WILL NOT DRAIN	<ul style="list-style-type: none"> • Drain line to remote tank is not submerged or trapped • Drain line is not sloped towards tank • Drain line plugged • Drain line too small
MOISTURE AFTER UNIT	<ul style="list-style-type: none"> • Re-Entrainment due to liquid loading • Gap or void in mist eliminator • Mist Eliminator damaged • Velocity too high through scrubber • Droplet size too small • Build-up of chrome on Mist Eliminator • Packing has settled (horizontal units) • Mesh pad mist eliminator plugged or saturated—liquid loading too high—throttle back nozzle spray pattern—clean mesh pad
LOW REMOVAL EFFICIENCY	<ul style="list-style-type: none"> • Insufficient or no water to spray nozzles • Mist Eliminator (if present) plugged or shifted • Velocity too high or too low • Improper pH of scrubbing liquor—inlet concentration too high • Packing plugged or settled •
DECREASED EXHAUST VOLUME—EXHAUST SYSTEM NOT VENTING PROPERLY	<ul style="list-style-type: none"> • Check fan—RPM—belts—rotation—fuses • Packing plugged • Chevron mist eliminator and or mesh pad plugged • Dampers closed or broken in closed position • Ductwork plugged with solids • High negative pressure in building • Leaks in ductwork
pH SYSTEM NOT WORKING PROPERLY	<ul style="list-style-type: none"> • Remove protective cover from probe and check for build-up • System not programmed properly • Chemical feed pump not working properly • No neutralizer in chemical feed tank • pH sensor located on probe has dried out due to lack of moisture—replace if necessary

MW-100 PARTS

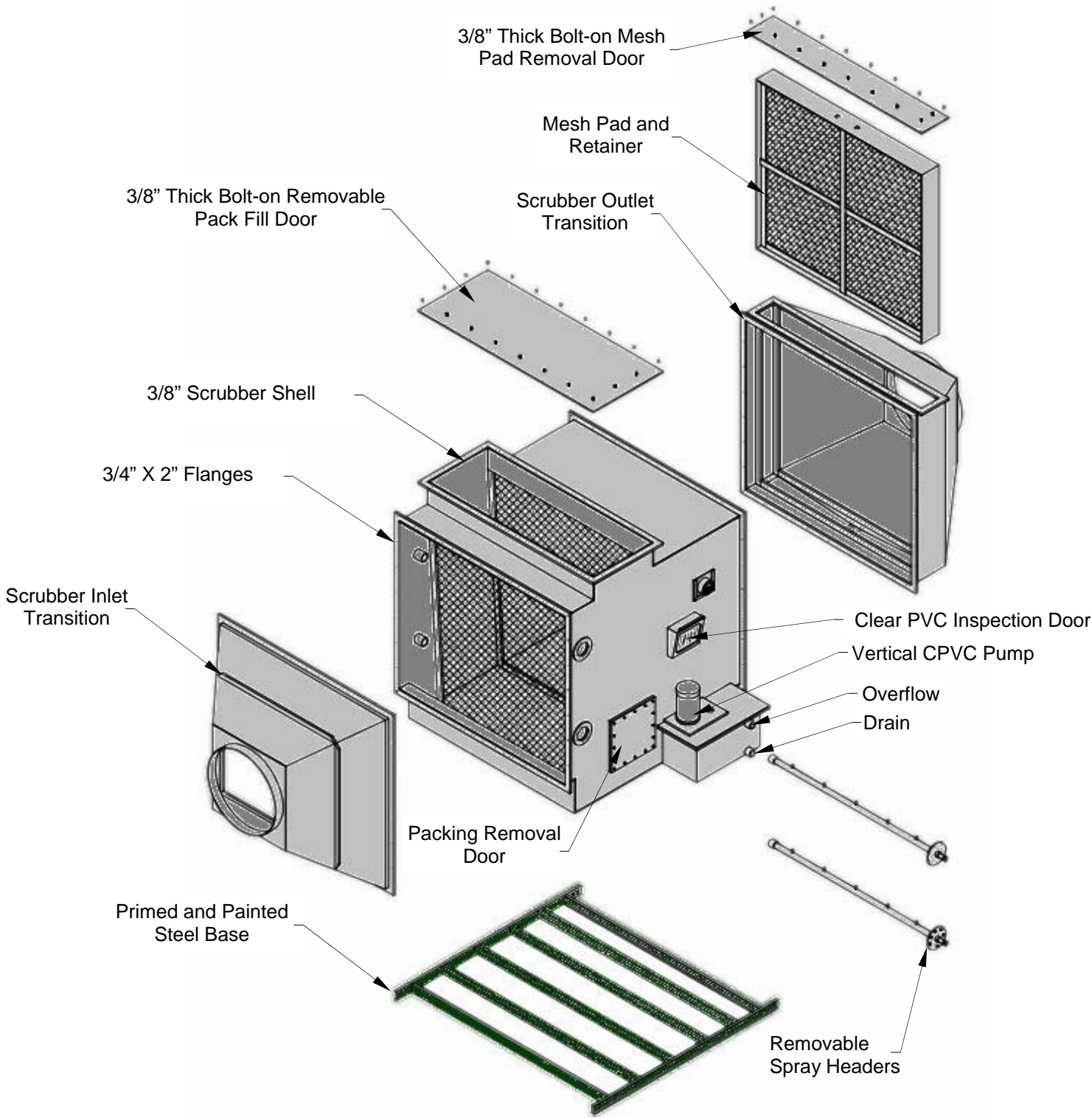

MW-200 PARTS

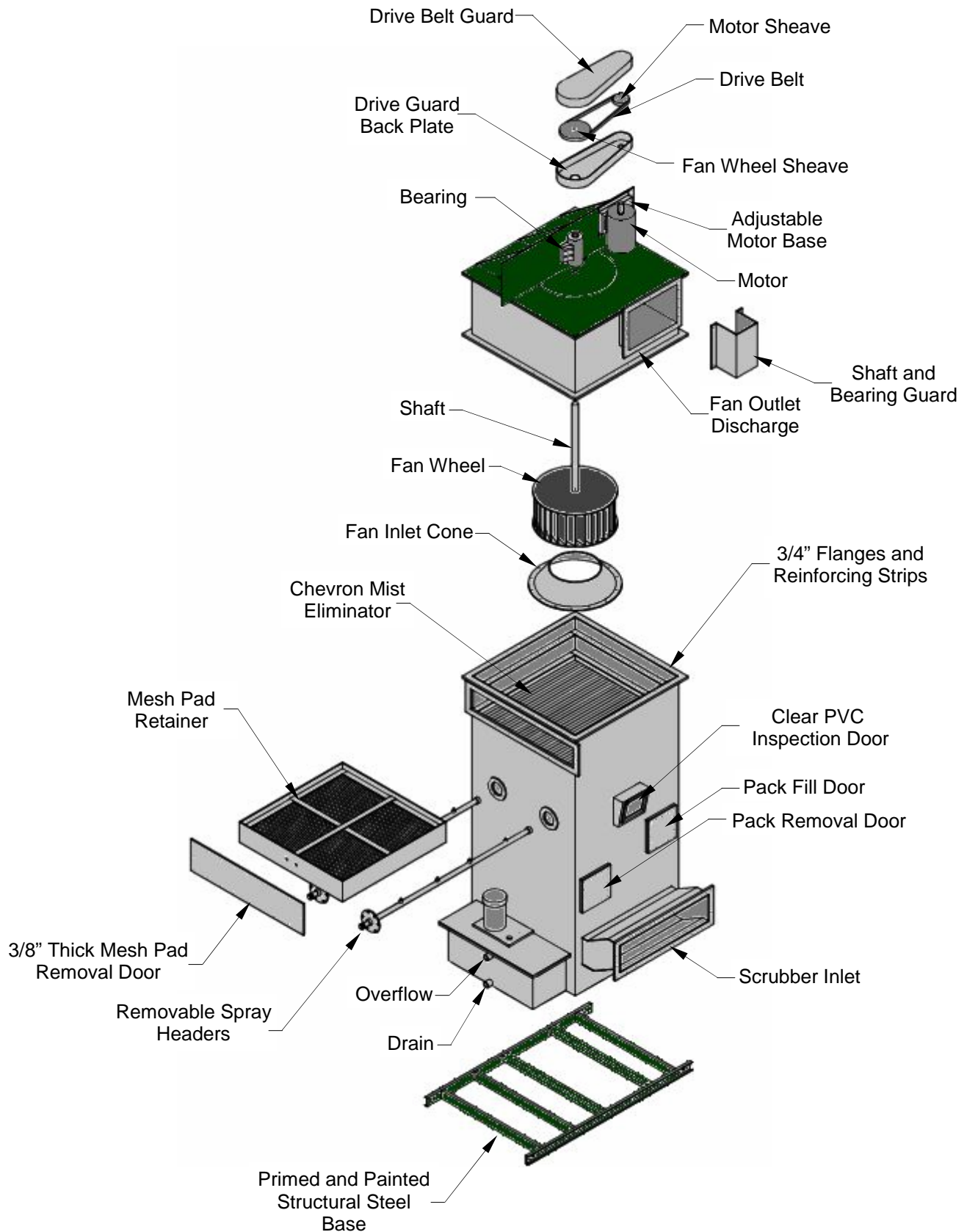

MW-300 PARTS

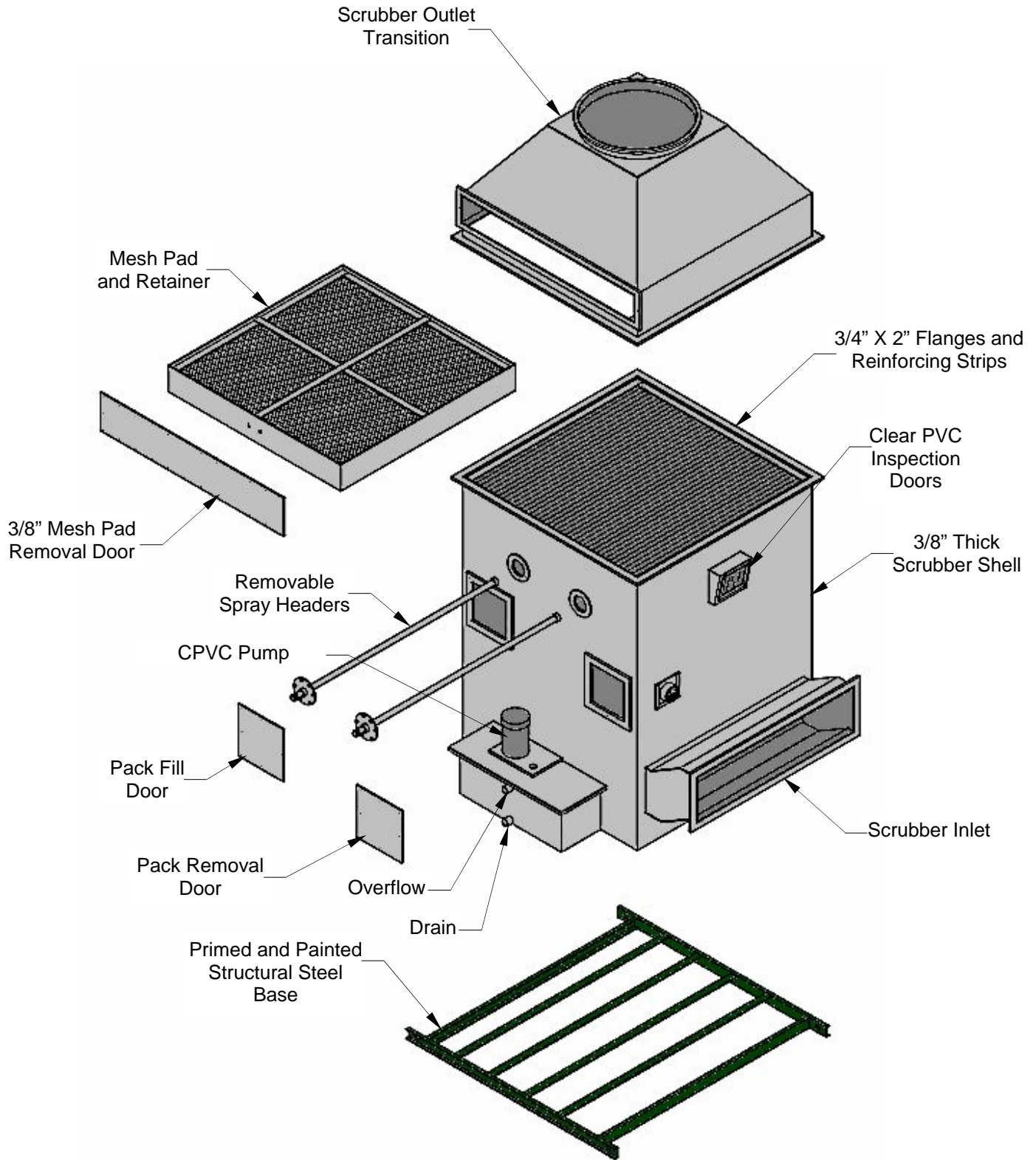

SCRUBBER WEIGHTS

Scrubber weights shown below are for scrubbers with two foot packed beds. For extended packed bed scrubbers add 4.2 lbs. per ft³ of packing. MW-200 and MW-300 scrubbers do not require additional weight for sump water. MW-100 scrubbers will require some calculation for additional weight due to extended sump. Calculate cubic feet of water based on a 10" liquid depth. Multiply ft³ of water by 62½ lbs. to find additional weight.

MW-100 HORIZONTAL					MW-300 VERTICAL				MW-200 FAN SCRUBBER				
CFM	DRY WT.	SUMP CAPACITY		OPER. WT.	DRY WT.	SUMP CAPACITY		OPER. WT.	DRY WT.	SUMP CAPACITY		OPER. WT.	
		GAL.	LBS.			GAL.	LBS.			GAL.	LBS.		
500	336	44	367	702	470	8.5	71	541	636	21	175	811	
1000	421	66	550	971	521	14	117	638	884	31	258	1143	
2000	476	77	641	1118	623	27	225	848	909	36	300	1209	
3000	554	105	875	1429	706	44	367	1072	1000	44	367	1366	
4000	635	133	1108	1743	756	56	466	1222	1233	62	516	1750	
5000	707	133	1108	1815	840	69	575	1414	1295	69	575	1870	
6000	849	138	1150	1998	947	84	700	1647	1363	84	700	2062	
7000	N/A								1552	100	833	2385	
8000	954	144	1200	2154	1064	108	900	1964	1589	108	900	2489	
10000	1099	172	1433	2532	1201	136	1133	2334	1831	136	1133	2965	
12000	1211	188	1566	2777	1333	166	1383	2716	2059	166	1383	3442	
14000	1280	188	1566	2846	1447	189	1574	3022	N/A				
16000	1389	211	1758	3146	1590	225	1874	3464					
18000	1617	222	1849	3467	1773	250	2083	3855					
20000	1716	244	2033	3749	1882	277	2307	4190					
22000	1815	266	2216	4031	2021	306	2549	4570					
24000	1939	294	2449	4388	2127	336	2799	4926					
26000	2083	316	2632	4715	2239	351	2924	5163					
28000	2206	344	2866	5072	2352	383	3190	5542					
30000	2305	366	3049	5354	2423	400	3332	5755					
35000	2577	427	3557	6134	2758	475	3957	6715					
40000	2954	488	4065	7019	3186	550	4582	7768					
45000	3226	550	4582	7808	3401	600	4998	8399					
50000	3563	611	5090	8653	3662	675	5623	9285					
55000	3835	672	5598	9433	3925	742	6181	10105					
60000	4107	733	6106	10213	4207	811	6756	10963					

MW-100 - MW-200 - MW-300 INLET/OUTLET TRANSITION LENGTHS																										
CFM	.5	1	2	3	4	5	6	7	8	10	12	14	16	18	20	22	24	26	28	30	35	40	45	50	55	60
MW-100	12		18				24						36						48							
MW-200	12						18						N/A													
MW-300	12						18						24			30			36			48				

Highest Value Exhaust and Pollution Control Equipment

“and the beat goes on”

Corrosion Resistant PVC Duct Corzan™ Duct Fiberglass Overlaid Duct



Turnkey
Installations



Corzan™
Duct



Motorized Dampers



Terminator™
Composite Mesh Pad
Exhaust Hoods

