



NeedleSearch Chute

www.loma.com

Versatile, proven metal detection systems for the textile and footwear industries



- **Simple** Chute arrangement, no moving parts
- **Easy to use** Intuitive touch screen with up to 50 product memories, bar code reader option
- **Sensitive** Designed for industry standard pin-head detection in garments and footwear
- **Stable** Unique search head design and filtering provides high levels of noise immunity
- **Reliable** High quality industry proven electronic components and conveyor parts

Packaging - Processing

Bid on Equipment

1-847-683-7720

www.bid-on-equipment.com

X-ray Inspection

Checkweighers

Data Capture

Designed to Survive



NeedleSearch Detectors

Finish:	Search Head - Aluminium with painted finish Conveyor - Stainless steel with bead blast finish	
Standard Height:	Infeed 1250mm +/- 50mm	49" +/- 2"
	Outfeed 700mm +/- 50mm	28" +/- 2"
System Length:	950mm	37"
Chute Width:	500mm	20"
Drive:	Gravity fall	
Supply Voltages:	220V 1ph N+E or 110V 1ph N+E	
Reject Type:	Alarm	
Protection:	IP 54	
Options:	Bar code reader, Product counting sensor, Network interface	

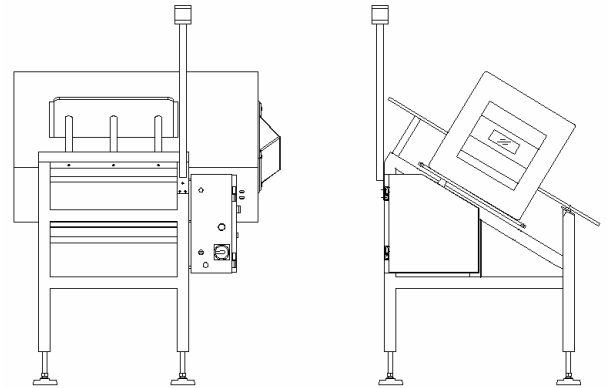

Technical Specification

FM model for detection of ferrous needles when the product has non ferrous metal present, e.g. zippers and fasteners

Classification of metal type

Auto self check

Electronic reset

Multi-lingual display

Full diagnostic messaging

Battery back up of stored data

Date and time stamped reject statistics

Aperture size

550 x 175mm 22" x 7"

Broken Needle Examples

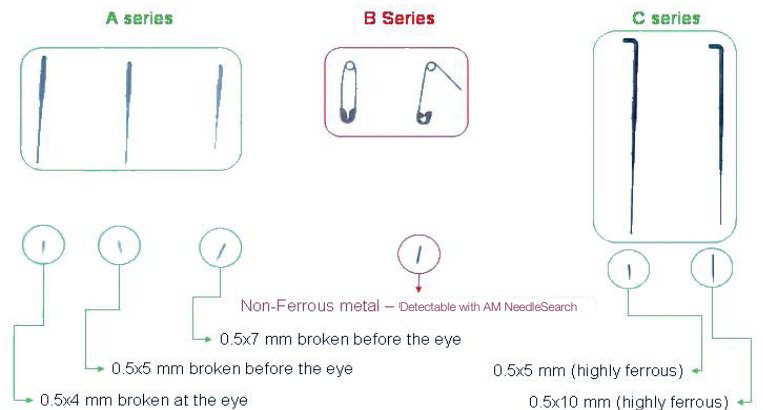

Loma Systems, Summit Ave, Southwood, Farnborough, Hampshire, GU14 0NY

Tel: +44 (0)1252 893300

Fax: +44 (0)1252 513322

Email: sales@loma.co.uk

Packaging - Processing

Bid on Equipment

1-847-683-7720

www.bid-on-equipment.com

Designed to Survive