



# operator manual

## *Impinger II 1100 Series*

This document includes:

- Safety Notices
- Specifications
- Installation Instructions
- Operating Instructions
- Cleaning Instructions
- Warranty Statement

Revision: K  
P/N: 2810075



Lincoln Foodservice Products, LLC  
1111 North Hadley Road  
Fort Wayne, Indiana 46804  
United States of America  
Technical Support Hotline: (800) 678-9511  
Telephone: (260) 459-8200  
[www.lincolnfp.com](http://www.lincolnfp.com)

## IMPORTANT WARNING AND SAFETY INFORMATION



**NOTE:**

This manual contains important safety and installation-operation instructions. Require all operators to read this manual thoroughly before installing, operating or servicing this equipment.



**WARNING:**

Improper installation, adjustment, alteration, service or maintenance can cause property damage, injury or death. Read the installation, operating and maintenance instructions thoroughly before installing or servicing this equipment.



**WARNING:**

This appliance is not intended for use by young children or infirm persons unless they have been adequately supervised by a responsible person to ensure that they can use the appliance safely. Young children should be supervised to ensure that they do not play with the appliance.



**DANGER!**

Do not work around conveyor belt with long hair, loose clothing, or dangling jewelry. Getting caught in the belt could result in serious injury.



**DANGER!**

For your safety, do not store or use gasoline or other flammable vapors or liquids in the vicinity of this or any other appliance.



**DANGER!**

Do not spray aerosols in the vicinity of this appliance while it is in operation.



**DANGER!**

If the power supply cord appears to be damaged, do not attempt to operate the unit. Contact a service agent or qualified electrician to repair!



**DANGER!**

Do not use parchment paper when placing food product through the toaster! Use of such materials may cause a fire and should never be placed in the toaster.

- Obtain from your local gas provider and post in a prominent location instructions to be followed in the event gas odors are detected.
- It is required that the oven be placed under a ventilation hood to provide for adequate air supply and ventilation.
- Minimum clearances must be maintained from all walls and combustible materials. See “spacing instruction” section for more information.
- Keep the oven free and clear of combustible material.
- Adequate clearance for air openings to the combustion control chamber on the right side of the oven is required.
- Do not obstruct the ventilation holes in the control panels, as these provide the combustion air for the burner and cooling air for the controls.
- The oven is to be operated only on the type of gas and/or electricity as shown on the specification plate.
- The power burner will not operate and gas will not flow through the burner without electrical power.
- This manual should be retained for future reference.
- The electrical wiring diagram is located under the control box covers.

## PURCHASER’S RESPONSIBILITY

It is the responsibility of the purchaser:

1. To see that the gas and electric services for the oven are installed on site in accordance with the manufacturer's specification.
2. To unload, uncrate, and install the oven in its proper location; in accordance with this installation / operation manual.
3. To see that the gas and electric services are connected properly by a qualified installer of your choice. *For installation in the State of Massachusetts: Installation of this oven must be performed by a licensed plumber or gas fitter.* All such connections must be in accordance with applicable code requirements. Refer to “Installation Codes and Guidelines” section for specific code references.
4. To arrange for inspection and operation check-out by an Authorized Service Technician as described below:

Do not attempt to operate the oven until connection of utility service has been fully inspected by an Authorized Service Technician or a Lincoln Foodservice Products, LLC Service Representative. This service is required by Lincoln Foodservice Products, LLC in order to assist the purchaser in proper start-up of the oven on site. Please note the specific details on the Warranty and make certain that service connections are made to proper utility services.

The warranty shall not apply if the oven(s) are started up and operated prior to the utilities and oven being inspected and check out made by an Authorized Service Technician or a Lincoln Foodservice Products, LLC Service Representative.

## TABLE OF CONTENTS

WARNING AND SAFETY INFORMATION.....	2
PURCHASER’S RESPONSIBILITY.....	3
MODEL NUMBER KEY.....	4
UTILITY SPECIFICATIONS – GAS & ELECTRIC.....	5
EXTERIOR DIMENSIONS.....	6
GENERAL INFORMATION.....	7
UNLOADING & UNCRATING.....	7
ASSEMBLY INSTRUCTIONS FOR STAND.....	7
STACKING INSTRUCTIONS.....	8
SPACING REQUIREMENTS.....	10
VENTILATION GUIDELINES.....	10
AMBIENT TEMPERATURE REQUIREMENTS.....	10
CANOPY VENTILATION RECOMMENDATIONS.....	11
SMOKE CANDLE TEST PERFORMED AT “START-UP / CHECKOUT”.....	11
UTILITY SERVICE LAYOUT.....	12
INSTALLATION CODES & GUIDELINES.....	12
PROGRAMMING.....	13
FUNCTIONS – THERMAL CUT-OUT SWITCH.....	15
RESTRAINT REQUIREMENT.....	16
CONVEYOR REMOVAL.....	17
FINGER REMOVAL & DISASSEMBLY.....	17
CLEANING INSTRUCTIONS.....	18
PREVENTIVE MAINTENANCE.....	19
HOW TO OBTAIN SERVICE.....	19
APPENDIX A: LABEL DEFINITIONS.....	20
WARRANTY.....	22

## MODEL NUMBER KEY

EXAMPLE: 1130-B00-U-K1801

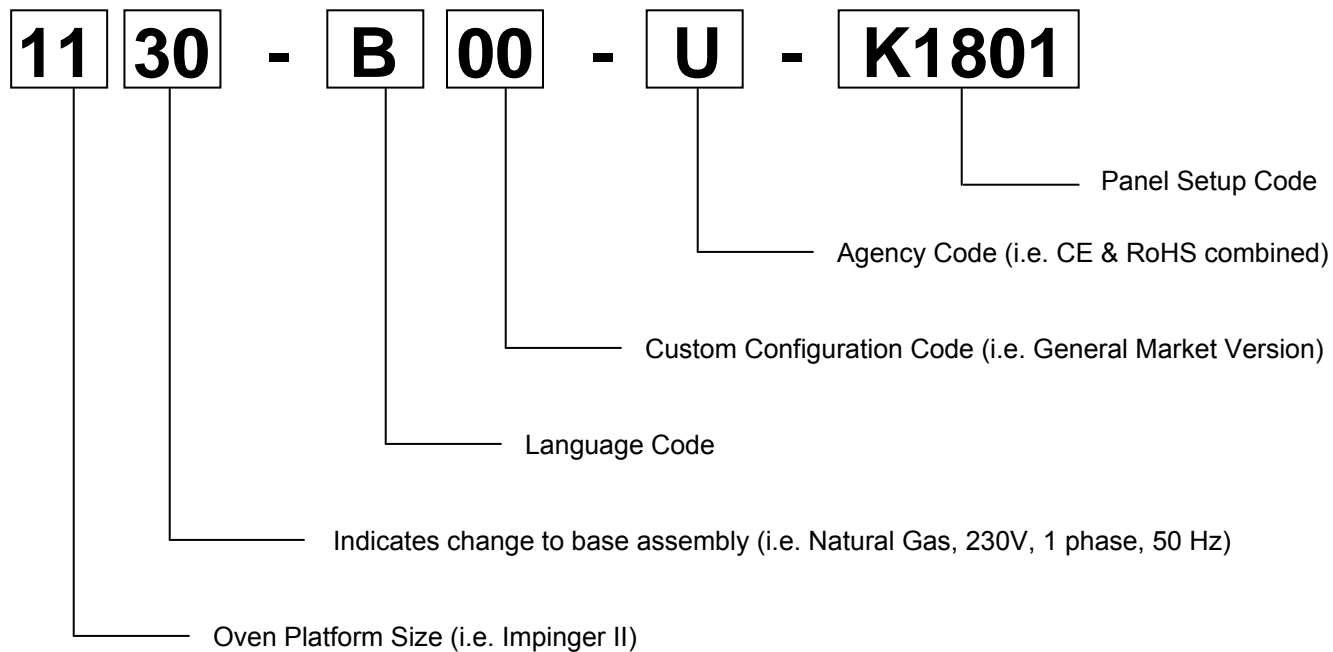

CODE	LANGUAGE	COUNTRY	CODE	LANGUAGE	COUNTRY
0	English	Dom. & Int. Default	N	Finnish	Finland
B	French	France/Luxembourg	O	Restricted	---
C	German	Germany	P	Norwegian	Norway
D	Italian	Italy	Q	English	Japan
E	Spanish	Spain	R	Swedish	Sweden
F	English	UK/India/Africa/Hungary	S	English	Australia
G	Spanish	Mexico/Latin America	T	Mandarin	China
H	Portuguese	Portugal	U	Restricted	---
I	Not Used	---	V	English	Pacific Rim/Korea
J	Danish	Denmark	W	English	Middle East
K	Dutch & French	Belgium	X	Not Used	---
L	Dutch	Netherlands	Y	Not Used	---
M	Greek	Greece	Z	Not Used	---

### AGENCY CODE TABLE

CODE	AGENCY
N	No Agency
E	CE & RoHS compliance combined
U	US & Canada compliance only
A	Advantage style oven to be phased-out
B	Australia AGA

## UTILITY SPECIFICATIONS REQUIRED – ELECTRIC

*Model	Energy	Power	Voltage	Current	Phase	Hz	Recommended Electrical Specification
1130-xxx-U-Kxxx	Electric	10kW	120/208V	48 Amps	1	60 Hz	4 Wires, 2 Pole + N + G
1131-xxx-U-Kxxx	Electric	10kW	120/240V	42 Amps	1	60 Hz	4 Wires, 2 Pole + N + G
1132-xxx-U-Kxxx	Electric	10kW	208V	28 Amps	3	60 Hz	4 Wires, 3 Pole + G
1133-xxx-U-Kxxx	Electric	10kW	240V	25 Amps	3	60 Hz	4 Wires, 3 Pole + G
1151-xxx-U-Kxxx	Electric	10kW	200V	29 Amps	3	50/60 Hz	4 Wires, 3 Pole + G
1161-xxx-U-Kxxx	Electric	10kW	240V	42 Amps	1	60 Hz	3 Wires, 2 Pole + G
1162-xxx-U-Kxxx	Electric	10kW	208V	28 Amps	3	60 Hz	4 Wires, 3 Pole + G
1164-xxx-U-Kxxx	Electric	10kW	400V	42 Amps	3	50 Hz	5 Wires, 3 Pole + N + G

\* REFERENCE MODEL NUMBER KEY

## UTILITY SPECIFICATIONS REQUIRED – GAS

Model	Energy	Power	Voltage	Current	Phase	Hz	Recommended Electrical Specification	Gas
1116-xxx-U-Kxxx	Nat. Gas	40,000 BTU	120 VAC	7 Amps	1	60 Hz	3 Wires, 1 Pole + N + G	40,000 BTU at 7 inches, H <sub>2</sub> O column**
1117-xxx-U-Kxxx	L.P. Gas	40,000 BTU	120 VAC	7 Amps	1	60 Hz	3 Wires, 1 Pole + N + G	40,000 BTU at 11 inches, H <sub>2</sub> O column**
1154-xxx-U-Kxxx	Nat. Gas	H <sub>s</sub> 13 KW	230 VAC	2 Amps	1	50 Hz	3 Wires, 1 Pole + N + G	H <sub>s</sub> 13 KW/HR at 1.7 kPa, H <sub>2</sub> O column**
1155-xxx-U-Kxxx	L.P. Gas	H <sub>s</sub> 13 KW	230 VAC	2 Amps	1	50 Hz	3 Wires, 1 Pole + N + G	H <sub>s</sub> 13 KW/HR at 2.73 kPa, H <sub>2</sub> O column**
1178-xxx-U-Kxxx	Nat. Gas	40,000 BTU	120 VAC	7 Amps	1	60 Hz	3 Wires, 1 Pole + N + G	40,000 BTU at 7 inches, H <sub>2</sub> O column**

GAS PRESSURE CONVERSION CHART			
Inches of Water Column	KPa	m-Bar	Millimeters of Water Column
3.5	0.87	8.70	88.9
4.5	1.12	11.2	114.3
7	1.74	17.40	177.8
10	2.48	24.87	254.0
10.5	2.61	26.11	266.7
11	2.73	27.36	279.4
14	3.48	34.81	355.6
14.5	3.61	36.05	368.3

\*\* NOTE: For proper operation, the gas valve requires a nominal inlet pressure of 7 inches of H<sub>2</sub>O for natural gas and 11 inches of H<sub>2</sub>O column for L.P. gas. A minimum inlet pressure of 1.0 inch of H<sub>2</sub>O column above the manifold setting (NAT. manifold 3.5" H<sub>2</sub>O, L.P. manifold 10" H<sub>2</sub>O) must be maintained with no pressure drop from the no load to full load condition. The maximum inlet pressure must be maintained at or below ½ PSIG (14.5 inches H<sub>2</sub>O column). Refer to the chart on the left for pressure conversions.

Electrical Supply for Australia:

Single Phase: 240 VAC, 50 Hz / 20 Amp; one neutral & one earth/ground.

Three Phase: 240/415 VAC / 20 Amp; three active, one neutral & one earth/ground.

All ovens require separate service and dedicated neutral.

NOTE: Do not install the (these) oven(s) in any area with an ambient temperature in excess of 95°F / 35° C. Doing so will cause damage to the unit.

# EXTERIOR DIMENSIONS

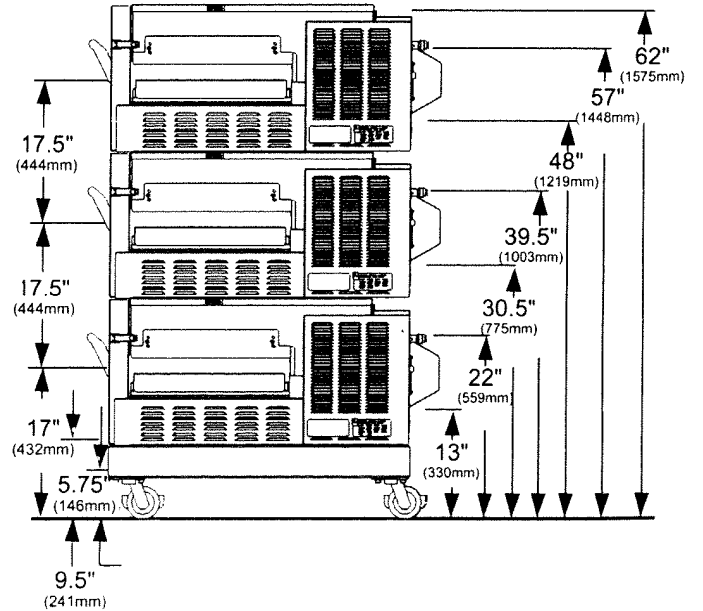
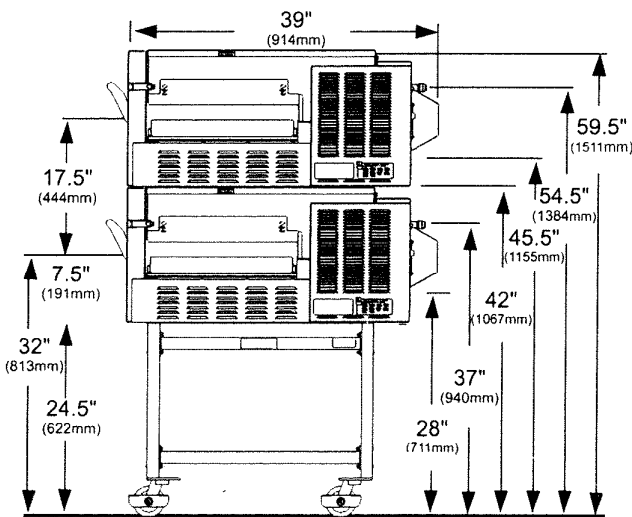
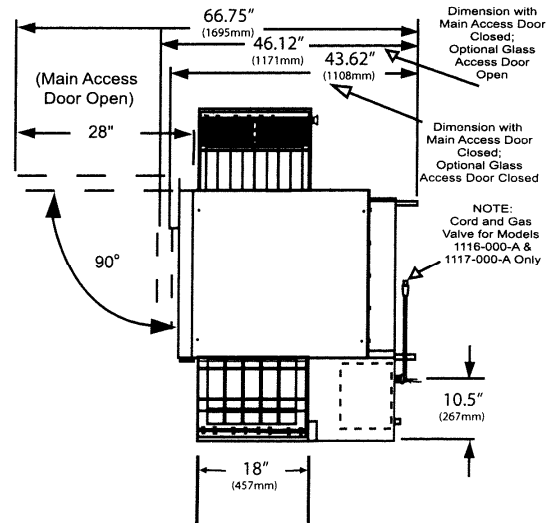
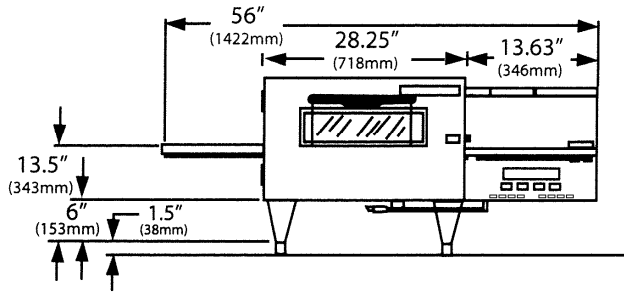

**BODY:** Stainless steel. Easy open front for simple cleaning.

**POWER:** Electric, or Gas and Electric

**CONVEYOR:** Stainless steel construction with flexible stainless steel belt, travel distances of 52 inches (1320 mm) with 24 inches (610 mm) in the baking area. Conveyor belt width is 18 inches (460 mm). Speed range 50 seconds – 30 minutes.

**DB LEVEL:** ≤ 70dba

## OPERATING

**TEMPERATURE RANGE:** Gas 300° - 550° F (149° - 288° C) Electric 200° - 550° F (93° - 288° C)

NOTE: Specifications are subject to change. Above data should be used for estimating purposes only.  
U.S. Patent Nos.: 3,844,213 and 4,154,862; Other Patents Pending.

## GENERAL INFORMATION

The instructions that follow are intended as a guide for preparing for the installation of the Impinger Conveyor Oven.

First and foremost, each crate should be examined before signing the Bill of Lading to report any visible damage by the trucker in transit, and to account for the proper number of crates.

### IF THERE IS APPARENT DAMAGE:

UNITED STATES AND CANADA: Arrangements should be made to file a claim against the carrier. As Interstate Commerce Regulations require that the claim must be initiated by the consignee.

ALL SHIPMENTS TO OTHER COUNTRIES: Freight terms will be developed and extended on an individual basis.

Proper and secure storage facilities should be arranged for the oven(s) if necessary to protect it from outdoor or damp conditions at all times before installation.

### PACKING AND WEIGHTS

All uncrated components of the Impinger Conveyor Oven will pass through a 30 inch wide door. The Impinger Conveyor Oven consists of:

Cartons or Crates	Weight of Each	Dimensions of Each
1 – oven (export)	486 lbs. (220.5 Kilo)	43 1/2" x 63" x 24" (1104.9 x 1600.2 x 609.6 mm)
1 – oven (domestic)	396 lbs. (180.0 Kilo)	42" x 59" x 23" (1066.8 x 1498.6 x 584.2 mm)
1 – stand (export & domestic)	45 lbs. (20.4 Kilo)	42" x 26 " x 5" (1066.8 x 660.4 x 127 mm)

### UNCRATING

When you have all the crates unloaded, open the crates and remove the plastic covers. Inspect at once for concealed damage. If anything appears to be damaged, contact the appropriate persons immediately to file a damaged claim. After completing this inspection, finish unpacking the oven and all other components. Be sure to remove the packing cardboard from the plenum shroud. Move the components inside near the area where they will be assembled in the order in which they will be assembled.

### ASSEMBLY INSTRUCTION

**DO NOT OVERTIGHTEN  
NUTS AND CRUSH TUBING!**

**POSITION THE TWO SIDE PIECES SO THAT THE HOLES  
FOR THE OVEN MOUNTING ARE AS SHOWN**

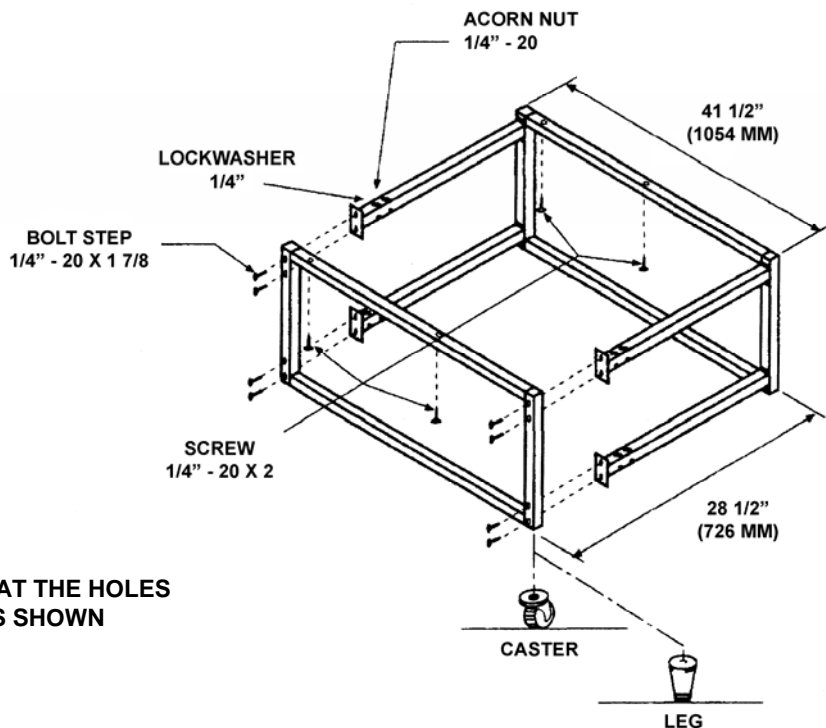

# STACKING INSTRUCTIONS

## FOR SINGLE OVEN

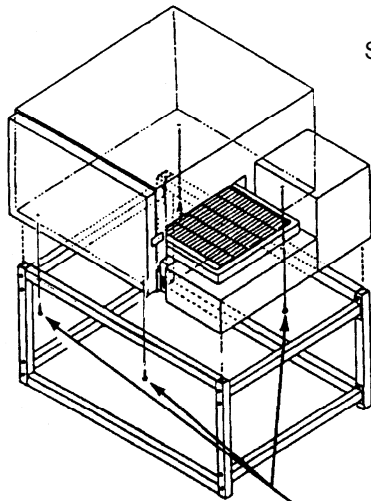

**CAUTION:**  
DO NOT USE  
STANDOFFS AS A  
LIFTING MEANS

Screw 1/4-20 x 2  
Use 4 each

**CAUTION: USE EXTREME CARE SO OVEN DOES NOT SLIP OFF STAND BEFORE SCREWS HAVE SECURED OVEN.**

## FOR DOUBLE OVEN (Step 1)

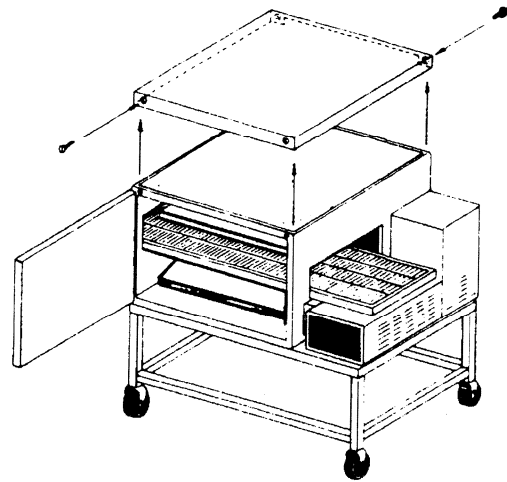

### BOTTOM UNIT

1. Remove 4 screws holding top in place and save (2 in front, 2 in rear).

## FOR DOUBLE OVEN (Step 2)

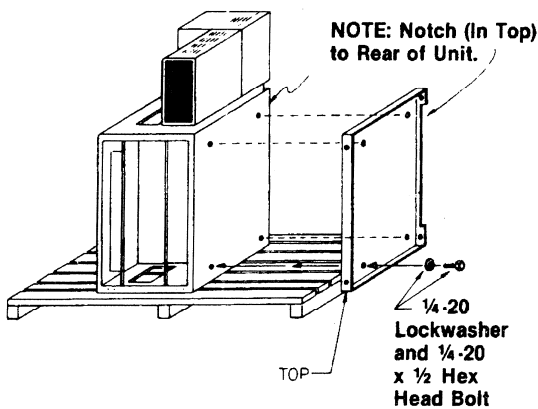

**NOTE: Notch (In Top) to Rear of Unit.**

1/4-20  
Lockwasher  
and 1/4-20  
x 1/2 Hex  
Head Bolt

### TOP UNIT

1. Remove door, conveyor and finger assemblies.
2. Turn unit on left side, as shown.
3. Drill holes in cover, as shown. Refer to step 3, pg. 14.
4. Assemble top of bottom unit to bottom of top unit with 4 bolts, as shown.

## FOR DOUBLE OVEN (Step 3)

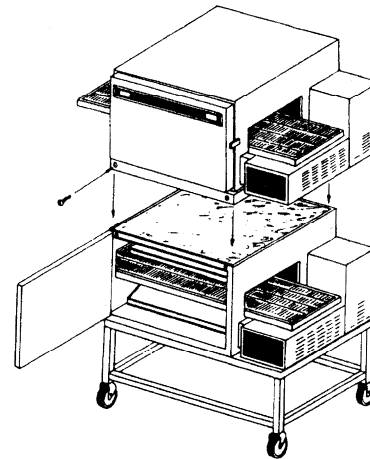

### STACKING UNITS

1. Position top unit over top of bottom unit and align top flanges with bottom unit.
2. Replace 4 screws, as shown (2 in front, 2 in rear).
3. Replace door, conveyor and finger assemblies.
4. Stacking is complete.

# STACKING INSTRUCTIONS (CONT'D)

## FOR TRIPLE OVEN

### (STEP 1)

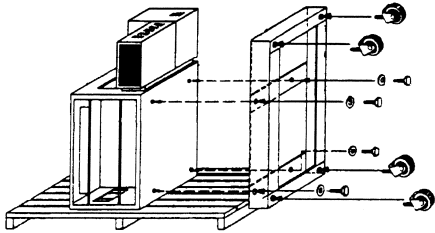

1. Remove door, conveyor and finger assemblies.
2. Turn unit on side, as shown.
3. Remove three screws from Front Cover.
4. Fasten base to oven with four 1/2 - 13 x 1/2" long Hex Head Bolts. Be sure to align the holes at the front of the oven and stand first.  
**Note: The front edge of the stand should line up with the front edge of the oven.**
5. Screw casters into base.

### (STEP 2)

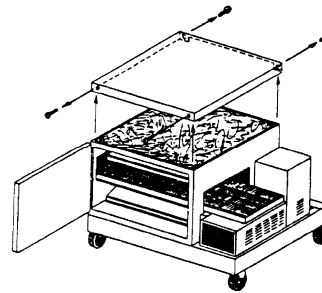

1. Set oven upright.
2. Remove oven top by removing 2 screws in front and 2 screws in back. (Save the screws.)
3. Replace door, conveyor and fingers.

### (STEP 3)

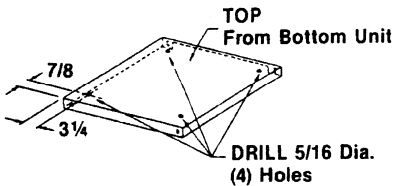

1. Prepare top for mounting as shown above.

### (STEP 4)

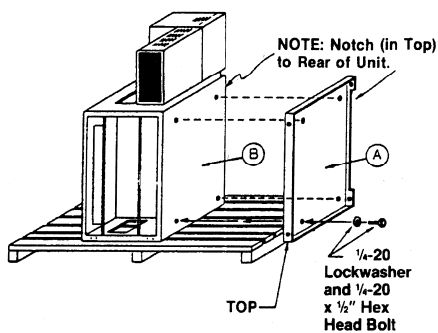

### OVEN TO BE STACKED

1. Remove door, conveyor and finger assemblies.
2. Turn unit on left side, as shown.
3. Assemble top of bottom unit to bottom of top unit with 4 bolts, as shown.

### (STEP 5)

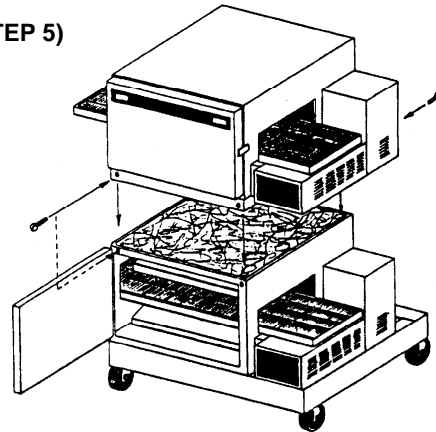

1. Position top oven over bottom and align the top oven flanges over the outside of the bottom oven, as shown.
2. Lower oven in place.
3. Fasten ovens together using the four screws from Step 2 (2-front, 2-back).
4. Replace door, conveyor and fingers.
5. Repeat steps 2 -5 to stack third oven.

## SPACING

The oven must have 6 inches (152 mm) of clearance from combustible surfaces. In case other equipment is located on the right side of oven, a minimum clearance of 24 inches (609 mm) is required from that equipment.

FOR ALL OVENS: A 24-inch (609 mm) clearance at the rear of the oven must be obtainable for service access.  
FOR IMPINGER® II OVENS: A permanently installed (unmovable) oven requires a minimum of 4 feet clearance on the right hand side to allow for conveyor removal, cleaning, and servicing.

**NOTE: Do not install this (these) oven(s) in any area with an ambient temperature in excess of 95° F / 35° C. Doing so will cause damage to the unit.**



**CAUTION:** Oven must be operated on an approved base only.

## VENTILATION

A VENT IS REQUIRED: Local codes prevail. These are the “authority having jurisdiction” as stated by the NATIONAL FIRE PROTECTION ASSOCIATION, INC. in NFPA 96 latest edition. In addition, to be in compliance with the NFPA 54 Section 10.3.5.2, this unit must be installed with a ventilation hood interlock that prevents the unit from operating when the ventilation hood is off. For further ventilation information, see below.

## VENTILATION GUIDELINES

A ventilation hood is required to remove heat and cooking odors. For gas ovens, a ventilation hood is also required to remove the products of combustion. The hood and HVAC installation must meet local codes to gain approval by the authority having jurisdiction. Requirements may vary throughout the country depending on the location by city, county, and state. Obtain information from the authority having jurisdiction to determine the requirements for your installation. Obtain information and review copies of codes or documents that will be used to inspect and approve your installation. Your ventilation hood supplier and HVAC contractor should be contacted to provide guidance. A properly engineered and installed ventilation hood and HVAC system will expedite approval and reduce oven maintenance costs. Proper ventilation is the oven owner’s responsibility.

The ventilation hood must operate in harmony with the building HVAC system. It typically requires between 750 and 2500 CFM exhaust. (The “Efficiency” of various hood designs makes it necessary to specify such a wide range of ventilator CFM.) Make up air must be supplied by either a hood design or the HVAC system. This will vary with hoods from various manufacturers.

**CAUTION: Prevent airflow through the cooking tunnel. Air must NOT be directed onto the oven front or at side of cooking area or rear of oven.**

Performance will be evaluated during Start-up Checkout by conducting a smoke candle test. The hood must capture all smoke from the oven. This is required to assure proper performance of the oven and to eliminate additional service calls that occur when ambient temperatures are too high. In all cases, the ambient temperature around the oven must be less than 95° F / 35° C when the oven is operating. In certain localities, other chemical or gaseous methods of detecting adequate capture will be the requirement to meet the local code authority.

The drawing shown on the next page is a typical installation and is intended to be a guideline. It is not a rigid specification. Hood dimensions and the positioning of the hood over the oven will vary with hood manufacturers.

NOTE: Lincoln can provide oven spec sheets that show the dimensions of the oven, KW or BTU ratings and other information that will be useful to both the ventilation hood supplier and the HVAC contractor.

*IN AUSTRALIA:* Refer to Standard AS 5601. This standard specifies the requirements for piping, flueing, ventilation and appliance installation associated with use of or intended use of fuel gases. The requirements of AS 5601 are to be used in conjunction with, but do not take precedence over, any statutory regulations that may apply in any area.

## LINCOLN IMPINGER® • 1100 SERIES TRIPLE DECK, DOUBLE DECK OR SINGLE UNIT CANOPY VENTILATION RECOMMENDATIONS

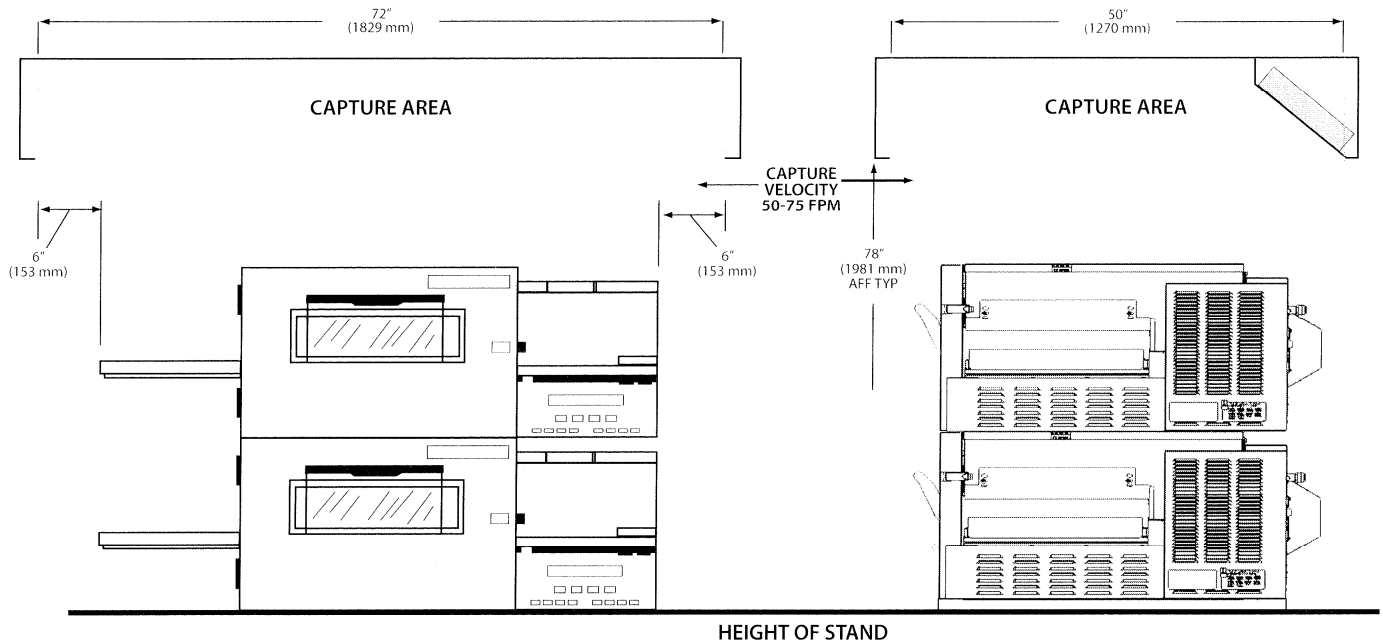

\* AFF = Above Finished Floor

### SMOKE CANDLE TEST – VENTILATION SYSTEM VERIFICATION

#### OVEN SET-UP FOR THIS TEST:

1. This test is to be done on the bottom oven of a multiple oven system, or a single oven.
2. The conveyor must be off.
3. The oven temperature must be set and operating at 550°F/288°C.

#### TEST PROCEDURE:

Note: Use Lincoln Smoke Candle #369361 (in Australia, an alternate method of coloring the air may be used).

1. Wear heat resistant gloves to prevent burns to your hands.
2. Put the smoke candle in a cake pan approximately 8 inches (200 mm) x 8 inches (200 mm) x 2 inches (50 mm) deep or equivalent.
3. Open the optional access window in the oven door, the oven door, or insert candle through conveyor opening.
4. Light the fuse of the smoke candle and immediately put the pan and candle into the center of the oven cavity, on the conveyor belt. (Close the access window or door.)
5. Observe the smoke pattern coming out of the oven openings and the collection of this smoke by the ventilation system.
6. The ventilation system must capture all the smoke from the oven.

## UTILITY SERVICE LAYOUT

Gas and electrical services for the Models 1116 and 1117 should be located as shown below. If flexible services are provided, they must meet code requirements for such installation.

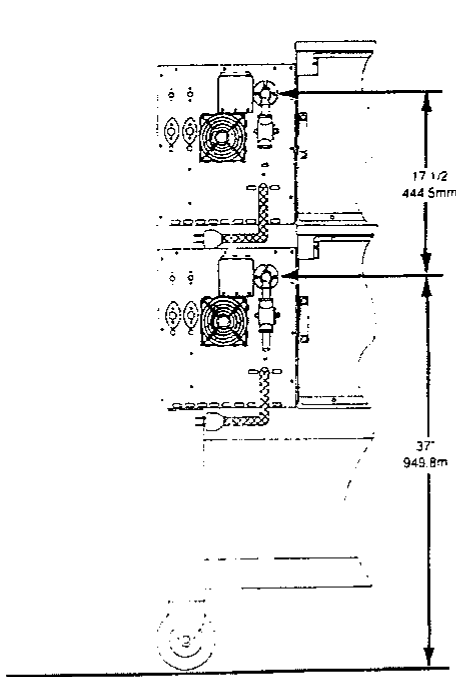

Back view of two Impinger® II Gas Ovens showing Gas Valve Installation and piping spacing.

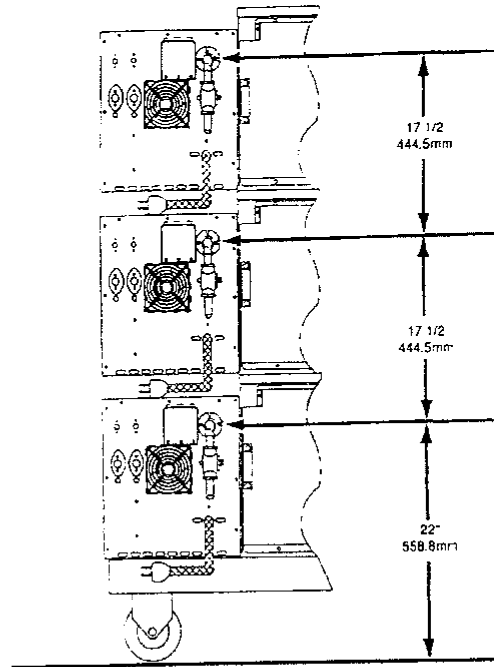

Back view of three Impinger® II Gas Ovens showing Gas Valve Installation and piping spacing.

## INSTALLATION CODES AND GUIDELINES

### GAS INSTALLATION

Safe and satisfactory operation of this oven depends to a great extent upon its proper installation, and it should be installed, as applicable in accordance with the National Fuel Gas Codes, ANSI Z223.1/NFPA 54 latest version, Manufacturers' Installation Instructions and local municipal building codes, ISO 203-1.

1. The oven and its individual shut off valve must be disconnected from the gas supply piping system during any pressure testing of that system at test pressures in excess of 1/2 psig (3.45kPa).
2. The oven must be isolated from the gas supply piping system by closing its individual manual shut off valve during any pressure testing of the gas supply system at test pressures equal to or less than 1/2 psig (3.45kPa).

**IN MASSACHUSETTS:** The minimum length of a flexible gas supply hose is thirty-six (36") inches.

**IN CANADA:** The installation of these appliances is to be in accordance with CSA B.149.1 latest version – Natural Gas and Propane Installation Code – and/or Local Codes.

**IN AUSTRALIA:** Adhere to AG 5601-2004 and 4563-2004 Gas Installation Code.

**YOU ARE NOW READY FOR THE SERVICES TO BE CONNECTED. THIS SHOULD BE DONE BY A QUALIFIED PLUMBER, ELECTRICIAN, OR INSTALLER OF YOUR CHOICE. FOR INSTALLATION IN THE STATE OF MASSACHUSETTS: INSTALLATION OF THIS OVEN MUST BE PERFORMED BY A LICENSED PLUMBER OR GAS FITTER. REFER TO “UTILITY SPECIFICATIONS” AND “INSTALLATION CODES AND GUIDELINES” SECTIONS FOR ADDITIONAL INFORMATION.**

NOTICE: The manual shut-off valve must be installed so that the test plug is on the oven side of the valve.

**DO NOT ATTEMPT TO OPERATE THE OVEN** until connection of utility service and installation has been fully inspected (START-UP CHECKOUT) by and Authorized Service Technician or a Lincoln Foodservice Products, LLC Service Representative. This service is required by Lincoln Foodservice Products, LLC in order to assure the oven(s) is/are properly installed and in working order. The warranty becomes effective upon verification of proper installation.

The warranty shall not apply if the oven(s) is/are started up and operated prior to the “START-UP CHECKOUT” being performed by an Authorized Service Technician or a Lincoln Foodservice Products, LLC Service Representative.



**DANGER!**

Do not work around conveyor belt with long hair, loose clothing, or dangling jewelry. Getting caught in the belt could result in serious injury.



**DANGER!**

If the power supply cord appears to be damaged, do not attempt to operate the unit. Contact a service agent or qualified electrician to repair!

## OPERATION / PROGRAMMING

### CONTROL PANEL ILLUSTRATION

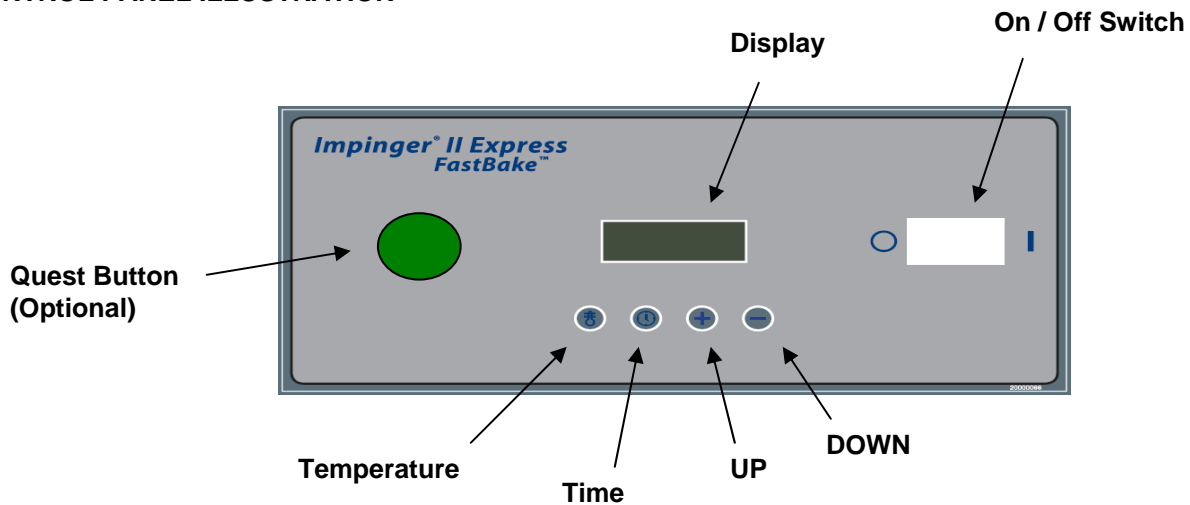

### MANUAL QUEST OPERATING INSTRUCTIONS (Optional Feature)

1. Press button on control box to illuminate green button and engage the Quest energy savings option. The oven is now in energy savings mode.
2. To bring the oven out of energy savings mode, simply press the button again to allow for normal operation. Notice that with the oven back in normal operating mode, the Quest button is no longer illuminated.

NOTE: When starting up the oven after the Quest system has been installed, the main fan may take upwards of sixty seconds to begin running. This is normal operating procedure.

## OPERATION / PROGRAMMING (CONT'D)

### AUTOQUEST OPERATING INSTRUCTIONS (Optional Feature)

AutoQuest is designed to provide energy savings automatically when the oven is not being utilized for extended periods of time yet maintain normal operating temperature for immediate use when needed. Currently, AutoQuest will activate after 14 minutes of inactivity during normal daily operation or 34 minutes after the unit is first turned on in the morning (20 minute oven warm-up + 14 minutes). You will notice that once AutoQuest has been activated the following will occur:

- Conveyor Belt will stop moving
- Fan Motor will slow down (noticeably quiet)
- Quest light will illuminate green (located on right side of control box)

In order to bring the oven back to normal operation, simply place food on the input side of the conveyor or open the access door and place the item in the oven. AutoQuest sensors will note the placement of food product on the end of the conveyor or when opening the access door. Sensor activation starts the conveyor and raises the rpm of the main fan motor thus returning the oven to normal operation. The AutoQuest light will not be illuminated while oven is in normal operation.

NOTE: Care should be taken to place the food item entirely on the conveyor to avoid the “blind spots” located on conveyor end (see illustration below).



#### CAUTION:

If you wish to change the conveyor direction, it is important to turn the oven off and restart to allow for proper sensor readings.

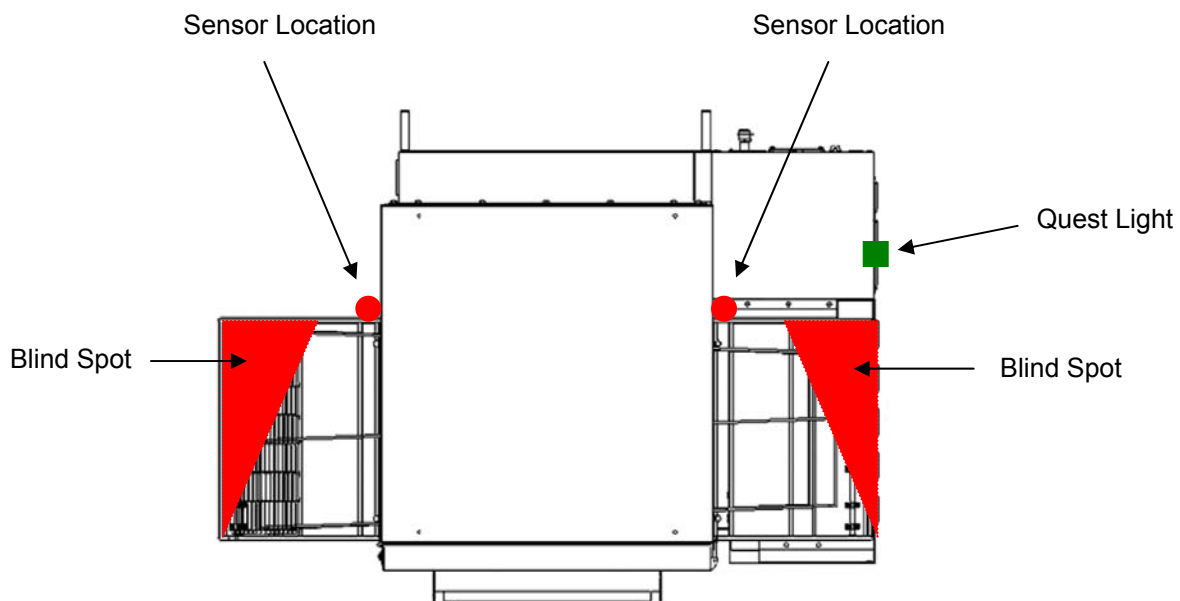

Top View of Oven

## OPERATION / PROGRAMMING (CONT'D)

### INTRODUCTION: START-UP AND SHUT DOWN

For the operator, the panel has power-up, run, and program menu modes. To start the oven, turn the power switch on. To shut down the oven, turn the power switch off.

### FRONT PANEL LAYOUT

The front panel contains four (4) momentary push-buttons: TEMP, TIME, UP, and DOWN. There is a two-line by sixteen-character VFD display.

### TEMPERATURE SETPOINTS

For Digital Advantage ovens there is one setpoint. To enter the setpoint mode, press the TIME & TEMP buttons together and hold for 5 seconds. Pressing the TEMP push-button, the display will show the current setting. Pressing the UP or DOWN push-buttons will raise or lower the temperature to the desired setting. In the Fahrenheit (or F mode) the temperature is adjusted in 1-degree increments. Pressing and holding the UP or DOWN keys will allow the settings to "roll" at a much faster rate. When the desired temperature is indicated, release all keys. After 5 seconds the selected setpoints will be stored and remain in memory.

### TIME SETPOINTS

There is one set point for the conveyor speed. Enter the setpoint mode as mentioned above. The speed can be set as follows:

- 1:00 to 9:55 in 5 second increments
- 10:00 to 12:45 in 15 second increments
- 13:00 to 19:30 second increments
- 20:00 to 30:00 in 1 minute increments

### JUMPING BETWEEN MENUS

Pressing the TIME pushbutton while in the TEMP setting mode (and vice versa) will cause the menu selection to jump over to that mode.

## DIAGNOSTIC MESSAGES

The Digital Advantage ovens have diagnostic messages within the control. Upon the unexpected event that there is a failure in the oven operation, the following messages will appear in the control:

### OPEN PROBE

This occurs when there is no temperature being sent to the controller from the baking chamber.

### SHORTED PROBE

This occurs when a constant temperature setting signal (as opposed to the normal cyclical cavity temperature) is being sent to the controller from the baking chamber. CAUTION: This message can occur when there is no gas supply to the oven. If the oven does not detect a temperature fluctuation in 5 minutes, the error message will appear. Be sure to check the gas valve and gas hose for proper connections.

### BELT JAM

This occurs when the conveyor motor fails.

## REVERSING SWITCH

The Digital Advantage 1100 Series has a belt direction reversing switch located on the back of the oven which allows for right to left or left to right operation.

## FUNCTIONS

### THERMAL CUT-OUT SWITCH

The Impinger II unit includes a "safety thermal cut-out switch" for your protection. This safety related device is designed to insure that the Impinger II unit will not overheat and damage the unit. In the unlikely event that the Impinger II unit would exceed the specified operating temperature range, the "safety thermal cut-out switch" will activate, thus blocking power to the Impinger II unit and causing it to turn off.



#### **WARNING:**

In order to avoid a hazard due to inadvertent resetting of the thermal cutout, this appliance must not be supplied through an external switching device, such as a timer or connected to a circuit that is regularly switched on and off by the utility.

## ELECTRICAL INSTALLATION



### **WARNING** **INT'L (CE):**

This appliance must be properly grounded at time of installation. Failure to ensure that this equipment is properly grounded can result in electrocution, dismemberment or fatal injury.

When installed, the appliance must be electrically grounded and its installation must comply with the National Electric Code, ANSI-NFPA 70, latest version, the Manufacturers' Installation Instructions, and applicable local municipal building codes.

**IN CANADA:** All electrical connections are to be made in accordance with CSA C22.2 latest version - Canadian Electrical Code and/or Local Codes.

**ALL OTHER COUNTRIES:** Local gas and/or electrical codes will prevail.

1. Strain Relief is provided with each oven. International Dealer/Distributors provide applicable power cord/plug for each customer.
2. All pole disconnection switch 3 mm open contact distance.
3. To prevent electrical shock an equal potential bonding ground lug is provided in the back. This allows the oven to be connected to an external bonding system.
4. If used as double or triple stack and each oven has its own disconnection switch, all switches should be close together.

### **RESTRAINT REQUIREMENT – Gas Oven(s) on Casters**

1. The installation shall be made with a gas connector that complies with the local codes for Connectors for Movable Gas Appliances, ANSI Z21.69 • CSA 6.16 latest version, and a quick-disconnect device that complies with local codes for Quick-Disconnect Devices for Use with Gas Fuel, ANSI Z21.41 • CSA 6.9 latest version.
2. The installation of the restraint must limit the movement of the oven(s) without depending on the connector, the quick disconnect device or its associated piping to limit the oven movement.
3. If the restraint must be disconnected during maintenance or cleaning, it must be reconnected after the oven has been returned to its originally installed position.

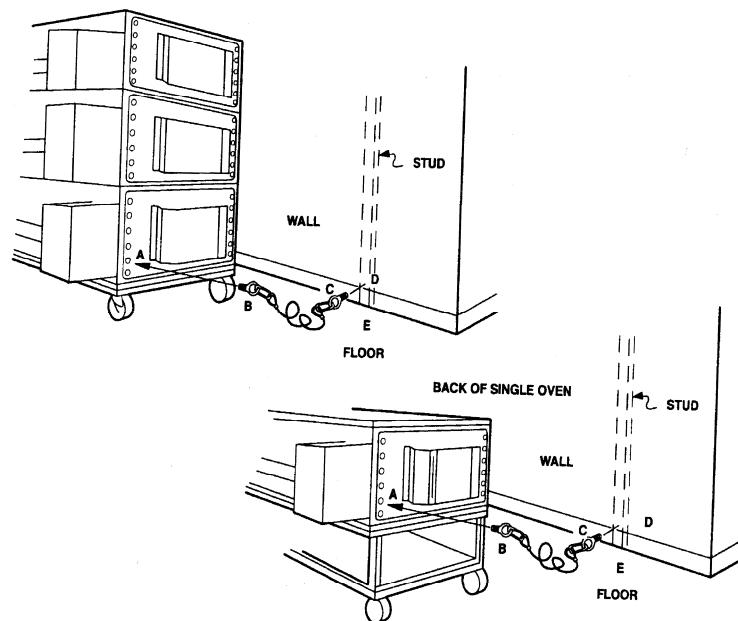

## **OPERATIONS**

1. Screw end B (lifting eye) of cable assembly to hole A. Use ¼ inch eye.
2. Screw end C (eye bolt) of cable assembly to stud in wall (D) or floor anchor (E).

**NOTE:** Installation point is the same for a single, double, or triple-stack oven.

## CONVEYOR REMOVAL

1. Remove door from front of oven by unfastening the latching mechanisms on the left side of the door (facing oven).
2. Pull conveyor out from oven baking chamber.
3. Re-install in reverse order.

## FINGER REMOVAL



**CAUTION:** Oven must be cool.

1. Open Door. NOTE: Door may be removed by lifting from hinges.

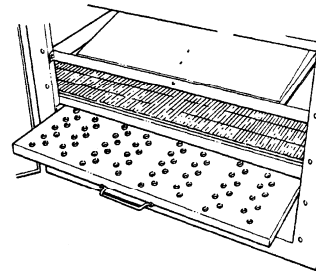
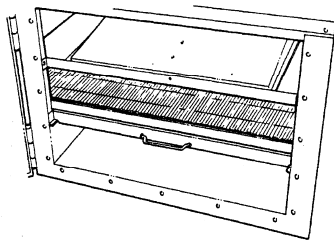

2. Grasp top finger housing, lift up from bracket and pull forward.

3. Grasp bottom finger housing handle and pull forward, sliding assembly out of oven.

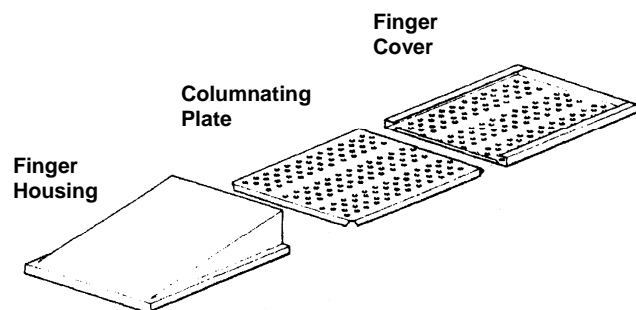
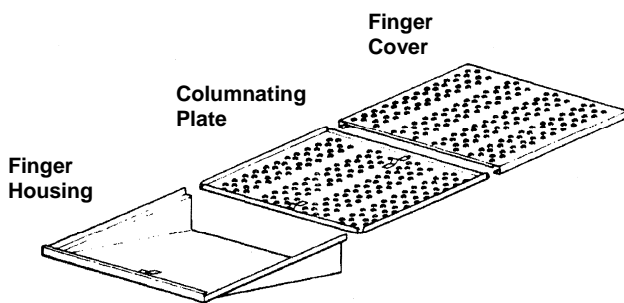

### BOTTOM FINGER ASSMBLY

4. Slide finger cover from housing. Lift out inner Columnating Plate.

### TOP FINGER ASSMBLY

5. Reassemble in reverse order. Be sure finger assembly seats securely over rear openings.

## OPERATOR MAINTENANCE



### WARNING:

Disconnect power supply before servicing or cleaning this oven. Safeguard power so it cannot be accidentally restored. Failure to do so could result in dismemberment, electrocution, or fatal injury.

Extensive engineering went into this oven to make it as maintenance free as possible. There is no lubrication required.

However, to achieve the maximum efficiency of the oven, it is necessary to keep it clean. For cleaning instructions, see below. The frequency listed is only the factory's recommendations. Your use and type of products will actually determine the frequency of cleaning.

If the oven fails to operate, check the circuit breaker and gas valve to be sure they are turned on. Also, check the fuses on the control panel to be sure that they are good before you call the Authorized Service Agency. The name and phone number of the Authorized Service Agency should be located on the oven or contact the factory at area code (260) 432-9511 for the name of the nearest Authorized Service Agency.

## CLEANING INSTRUCTIONS

The Lincoln Impinger oven contains electrical components. Before cleaning the oven, switch off and disconnect the oven from the electrical supply.

No electrical components should be subjected to moisture. It is, therefore, important that the oven is wiped down carefully. NEVER throw buckets of water over the oven or subject it to pressure washing from a hose or a pressure spray. If water or other liquid is spilled on the oven, make sure that none has entered the control box area before switching on. If in doubt, call your service company.



### CAUTION:

Oven must be cool. Do not use power-cleaning equipment, steel wool, or wire brushes on stainless steel surfaces.

### DAILY

1. Clean exterior surfaces of the oven by wiping it down with a mild detergent and clean water, or a commercial stainless cleaner.
2. Clean crumb pans and guards by washing with a mild detergent solution and rinsing with clean water.
3. Clean the interior by sweeping up all loose particles, then wash with a mild detergent solution and rinse with clean water.
4. Clean the conveyor belt by wiping with a cleaning cloth or brushing with a **soft** wire brush. Lincoln catalog #369217.



### CAUTION:

Do not use caustic or alkaline cleaners on the interior of the unit. These cleaners can damage the specially finished surfaces of the unit interior.

On **exterior** of oven, deposits of baked-on splatter, oil grease, or light discolorations may be removed with any of several commercial cleaners. Consult with your local supplier.



### CAUTION:

When using cleaning solutions, be sure they meet local and national health standards.

### WEEKLY

1. Remove fingers, disassemble and clean. See "Finger Assembly Removal" section for more information.
2. Remove conveyor, disassemble and clean. See "Conveyor Removal" section for more information.

NOTE: Be sure to clean and inspect the ventilation hood, in accordance with the ventilation hood manufacturer's specifications.

## **PREVENTIVE MAINTENANCE**

Although this oven has been designed to be as trouble free as possible, periodic Preventive Maintenance is essential to maintain peak performance. It is necessary to keep the motors, fans, and electronic controls free of dirt, dust and debris to insure proper cooling. Overheating is detrimental to the life of all components mentioned.

The periodic intervals for preventative cleaning may vary greatly depending upon the environment in which the oven is operating.

You must discuss the need for Preventive Maintenance with your Authorized Service Company to establish a proper program.

If there is any question the service company cannot answer, contact the Lincoln Foodservice Product, LLC Service Department.

## **HOW TO OBTAIN SERVICE**

If the oven fails to operate, check the circuit breaker to be sure it is turned on (on a gas oven check the manual gas valve to insure it is in the "ON" position). In addition, check the fuses on the back of the oven to be sure that they are good before you call the Authorized Service Agency. The name and phone number of the Authorized Service Agency should be located on the oven or contact the factory for the name of the nearest Authorized Service Agency.

## APPENDIX A – LABEL DEFINITIONS



CAUTION – HOT SURFACE



POWER ON



CLOCK, TIME SWITCH, TIMER

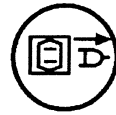

DISCONNECT POWER



TRANSFORMER



TEMPERATURE, HEAT



DANGEROUS VOLTAGE

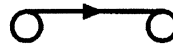

CONVEYOR



EQUIPOTENTIALITY GROUND



FAN



PROTECTIVE EARTH GROUND

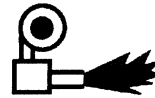

BURNER



EARTH GROUND



HEAT CYCLE

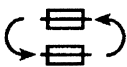

CHANGE FUSES



READY, TIMER INDICATOR

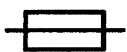

FUSE



RESET



POWER OFF



HIGH TEMPERATURE, HEAT

## APPENDIX A – LABEL DEFINITIONS (CONT'D)

**A**

AMPS

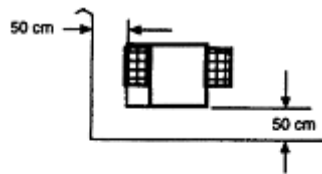

SERVICE  
ACCESSIBILITY,  
PROVIDE MINIMUM  
REAR AND SIDE  
CLEARANCE

**V**

VOLTS



ORIFICE – MAIN

**kW**

KILOWATTS / HR



ORIFICE – LOW FIRE



TYPE OF GAS



AC

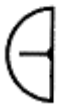

½ COOK TIME