

## LEWA *ecosmart*<sup>®</sup>

Diaphragm metering pumps  
at a smart price

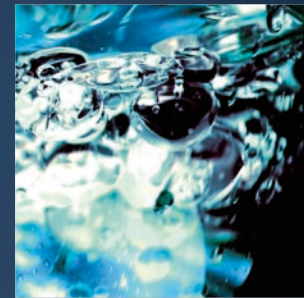

- best price-performance ratio
- high metering precision
- hermetically tight
- compact design

# LEWA ecosmart: The clever idea for plant engineering. Solid technology at an attractive price.



LEWA ecosmart pumps:  
For simple metering tasks ...



...as well as for challenging applications  
in chemistry and petrochemistry.



Water processing, drinking water purification and  
industrial water conditioning are among the fields  
of application for LEWA ecosmart.

**LEWA ecosmart:**  
**The safe, economic and hermetically tight diaphragm metering pump in proven quality. For pressures up to 80 bar and flow rates up to 300 l/h at temperatures up to 120°C.**

LEWA's philosophy is to detect market trends as early as possible, in close contact and dialogue with the customer.

This has taught us one thing: For industrial operators, efficiency over the life cycle is an important selection criterion in the purchase of systems and their components. Here the costs for buying and operating a system over its full service life are a crucial distinguishing and competitive feature.

The diaphragm metering pump LEWA ecosmart was designed with the focus on these aspects. It offers the best price-performance ratio in

this class and meters the often costly fluids with very high precision. As a positive displacement pump, it works with high efficiency.

LEWA ecosmart also excels with its dimensions: No other metering pump of this class has a more compact design. In plant engineering, aggregates with a compacted footprint are appreciated, as the space for the installation of devices and systems is becoming increasingly more scarce and expensive.

Small, modular systems allowing the operator to flexibly adapt his capacities to changing demands or market developments are often the better

alternative to a large system geared to one single product only.

Here the LEWA ecosmart metering pumps are recommendable as an economic solution: The low costs of purchase and operations are as convincing as the robustness and longevity of the pumps.

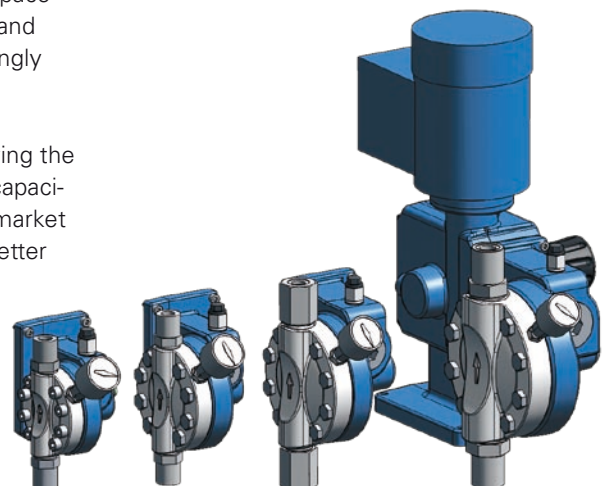

Four sizes of  
LEWA ecosmart  
cover flow rates  
up to 300 l/h.



A typical installation of LEWA ecosmart pumps:  
Upstream processes in the oil & gas industry.

**Typical fields of application  
for LEWA ecosmart diaphragm  
metering pumps:**

- Water treatment in power plants
- Metering of additives in industrial water processing
- pH adjustment
- Dosing of solvents in the chemical industry
- Feeding of corrosion inhibitors
- Dosing of colorants and flavors in the food industry
- Additive metering in the plastics industry
- Injection of chemicals in the oil & gas industry

In all these fields of application, LEWA ecosmart pumps meet the highest requirements: They pump and meter safely, economically, precisely and reliably, independent of the tasks in a wide variety of fields.

**Safe:** The sandwich diaphragm design with diaphragm monitoring ensures absolute leak-free use. LEWA ecosmart reliably reports any damaged diaphragm. Yet the pump remains leak-tight, and operations can continue for a certain time. A pressure relief valve in the hydraulic system of the pump head prevents potential overload situations of the pump. In LEWA ecosmart, it is individually adjustable.

**Economic:** Already in purchase LEWA ecosmart pumps have an even more convincing price. The low life cycle costs are based on the high overall efficiency with low energy costs. A minimum of maintenance underlines the operating efficiency.

**Solid:** The PTFE sandwich diaphragm, the Diaphragm Protection System (DPS) and the optimized check valves are from the proven LEWA program.

In spite of the standardization, individual configurations are optionally possible, such as offshore paint, material test certificates and testing according to API (American Petroleum Institute).

# Designed for the specific requirements of your market: Precise. Leak-free. Compact.

Highest metering  
precision

Standard drives according  
to IEC and NEMA

#### Performance overview:

**Pressure** up to 80 bar  
**Flow rate** up to 300 l/h  
**Temperature** up to 120°C  
**Stroke length** 15 mm

#### Standard material for parts in contact with the fluid:

- 1.4404/SS 316L
- Alloy 20
- PVC

Top operational  
safety

Sandwich design with  
diaphragm monitoring

Simple installation  
and start-up

Compact design

Suction pressure  
down to 0.1 bar abs.

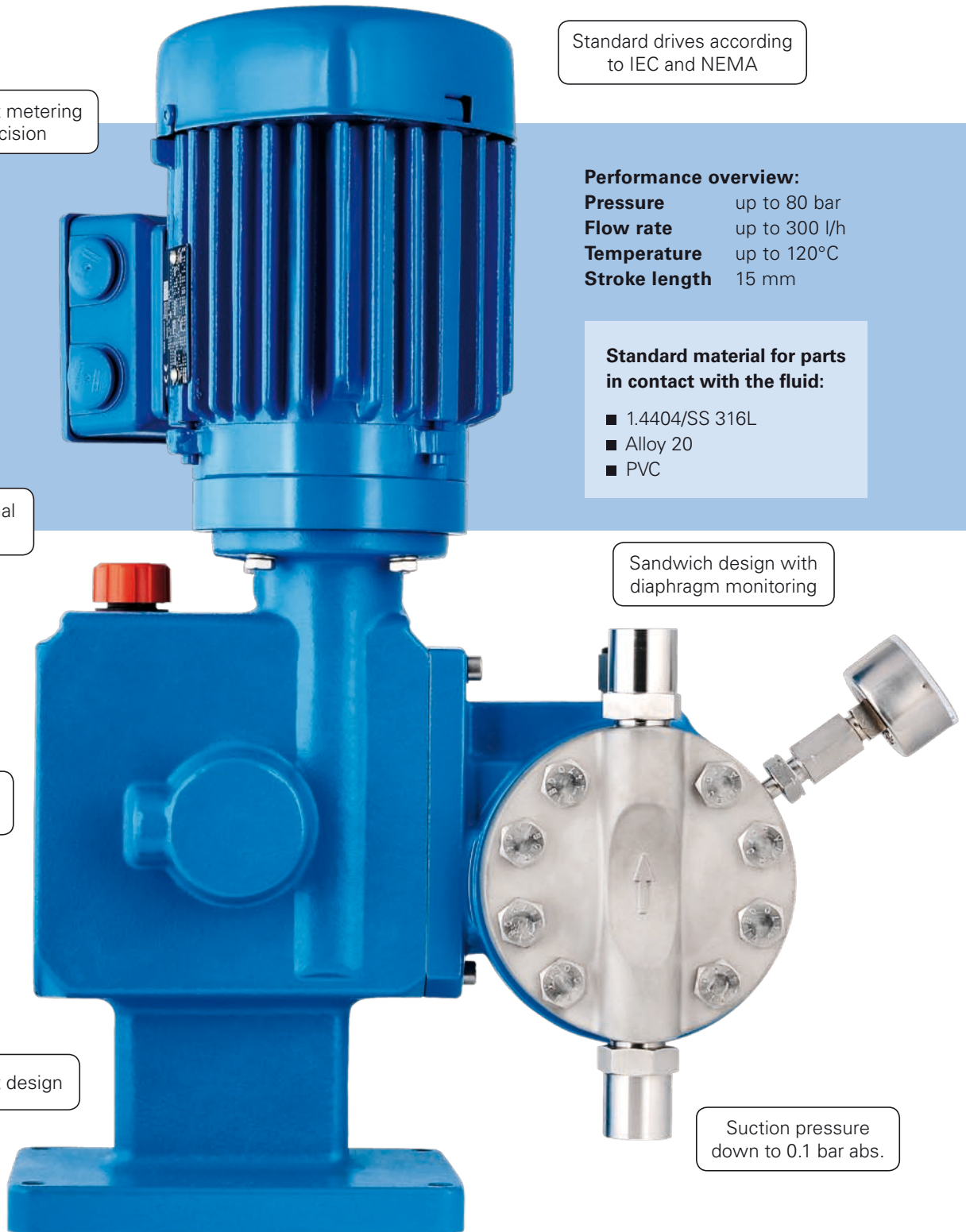

LEWA ecosmart pumps are  
ATEX zone 1 and zone 2 compliant.



By default, LEWA ecosmart is provided with diaphragm monitoring.



Linear stroke adjustment at the hand wheel in stages of 0.05 mm is possible both at standstill and during operations.

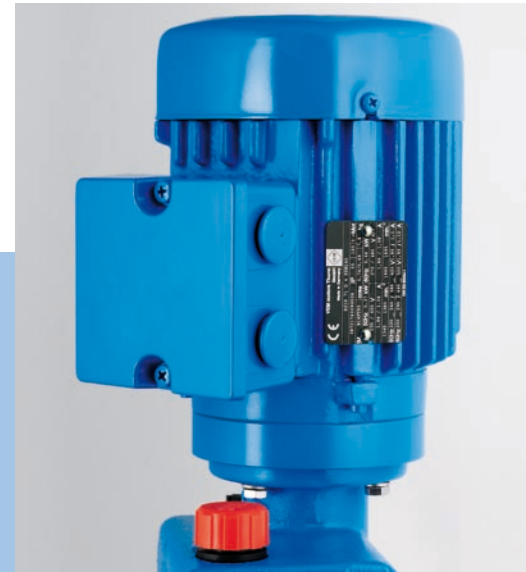

For LEWA ecosmart, standard drives according to IEC and NEMA are used.

**Proven in practice – in LEWA quality**

Reliability of the components is an essential factor in process safety. Practice-tested developments form the basis. LEWA ecosmart pumps are based on well-known and solid LEWA technology. Therefore they have no problems complying even with the rigid guidelines of API 675 (American Petroleum Institute). Crucial components of the proven LEWA program are used – such as the PTFE sandwich diaphragm with diaphragm monitoring, the patented DPS and optimized check valves.

**Diaphragm protection system (DPS):**

When running diaphragm pumps, leak-free use and operational safety are mandatory, even more so for fluids which are hazardous, abrasive,

pollutive or sensitive. To keep stress on the diaphragm as low as possible, in LEWA ecosmart the diaphragm is driven hydraulically. In combination with the diaphragm protection system (DPS), long service life of the diaphragm can thus be ensured.

**Diaphragm monitoring:**

Any damage to a diaphragm is reliably reported by the diaphragm monitoring system. The safety sandwich design allows to continue operations of the pump up to a scheduled standstill

without any problems. The necessary diaphragm change is very easy to handle.

**Optimized check valves:** Operations safety and risk of failure essentially depend on check valve quality. Hence the design of the valves is adapted to the individual application. Our decades of experience help us to always find the optimal solution.

For each of the four sizes of LEWA ecosmart, there is an appropriately dimensioned PTFE diaphragm in safety sandwich design.



# LEWA ecosmart: Safety. Metering precision. Value for money.

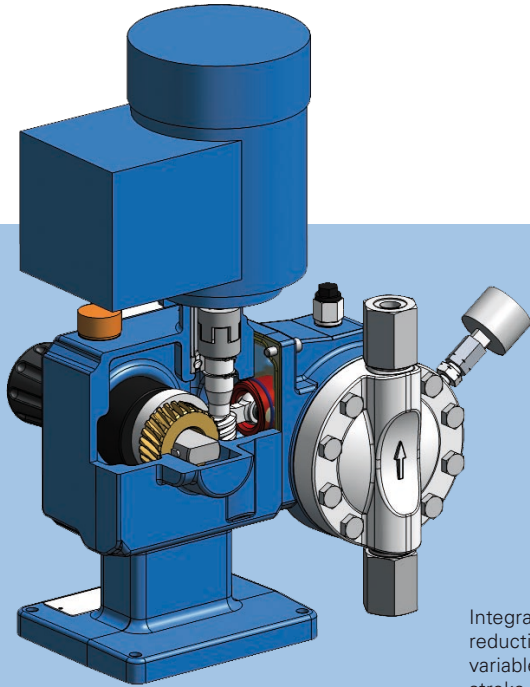

Integrated worm reduction gear with variable eccentric for stroke adjustment.

## Stroke adjustment

By default, the drive units are equipped with manual stroke length adjustment.

Optionally, LEWA ecosmart can also be equipped with an electric actuator for stroke length adjustment.

## LEWA ecosmart pumps employ the proven variable eccentric design for adjusting the metering rate. And this is how it works:

The drive shaft powers, via the worm gear and the sliding shaft, the variable eccentric. The connecting rod transmits the rotary movement of the variable eccentric as an oscillating movement to the plunger. The stroke length of the displacement motion is adjusted – at standstill or during operations – by radial shifting of the variable eccentric. To this end, an adjusting spindle axially shifts the sliding shaft. Via an inclined groove, the axial movement of the sliding shaft is converted into a radial movement of the variable eccentric.

## The advantages of this variable eccentric drive:

- Proven principle: Stroke length is adjusted where it is produced – at the eccentric. Both at standstill and during operations, linear stroke adjustment at the hand wheel is possible in stages of 0.05 mm
- Harmonic movement of the plunger even in the partial stroke range
- Different stroke frequencies of the drive units facilitate adaptation to various fluids and conditions
- Long service life thanks to solid dimensioning and durable materials, oil bath lubrication, weather and surge water protection
- The drive system uses three-phase and AC motors; frequency control for speed adaptation is also possible
- Simple operation, easy maintenance



No metering pump of this class has a more compact design.

# At a glance: Technical data LEWA ecosmart

## Performance overview

For determining stroke frequency and pump head size.

Type	Plunger Ø [mm]	Q <sub>theor</sub> [l/h] at full stroke length and frequency n [min <sup>-1</sup> ] n =					p <sub>max</sub> Pump pressure [bar]
		80	109	136	163	218	
1	6	2,0	2,8	3,5	4,1	5,5	80
	8	3,6	4,9	6,2	7,4	9,9	80
	11	6,8	9,3	11,6	13,9	18,6	80
2	14	11,1	15,1	18,8	22,6	30,2	80
	17	16,3	22,3	27,8	33,3	44,5	56
3	22	27,4	37,3	46,5	55,8	74,6	33
	28	44,3	60,4	75,4	90,3	120,8	19
4	35	69,3	94,4	117,8	141,1	188,8	12
	42	99,8	135,9	169,6	203,2	271,8	7

## Assembly dimensions

Type	Plunger Ø [mm]	L [mm]	W [mm]	H <sub>0,18KW</sub> [mm]	H <sub>0,37KW</sub> [mm]	H <sub>0,55KW</sub> [mm]
1	6 - 11	220	285	436	456	527
2	14 - 17	230	300	436	456	527
3	22 - 28	270	305	436	456	527
4	35 - 42	285	340	436	456	527

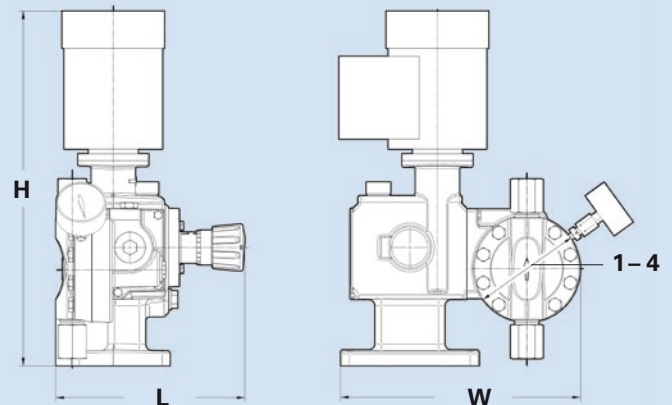

The H values refer to the standard motors used by LEWA.

## Enquiry data for designing your LEWA ecosmart

To design your pump, we need the basic details on the right.

LEWA GmbH

Phone +49 7152 14-0

Fax +49 7152 14-1303

lewa@lewa.de

We will answer your inquiry immediately.

### Metering fluid

Flow rate required	.....	[l/h]
Operating pressure at discharge flange	.....	[bar] abs
Operating pressure at suction flange	.....	[bar] abs
Operating temperature (OT) max./min.	.....	[° C]
Density at OT	.....	[g/cm <sup>3</sup> ]
Viscosity at OT	.....	[mPa · s = cP]
Solids content/Solids density	.....	[%/g/cm <sup>3</sup> ]
Solids grain size/Solids hardness	.....	[mm/Mohs]

### Motor data

Hazardous area protection	.....
Protection type	.....
Voltage	..... [V]
Current type	.....
Mains frequency	.....