

## CS-300/1000

Automatic  
Case Sealers

### Innovation

*“Value driven solutions that increase your  
case packaging productivity”*

#### Easy To Operate

- Linear hand-wheel adjustments with digital indicators
- Settings easily reproducible
- No fine tuning required



CS-300



CS-1000

#### Safe To Operate

- Folding area fully guarded
- Controlled return stroke of the flap folder
- No scheduled maintenance

#### Seals Wide Range Of Case

- All types of flutes
- Double wall and single wall
- Most common sizes



# CS-300/1000

## Easy To Use

- Rapid adjustment to a different case size
- No periodic lubrication necessary
- Long life drive belts
- Extremely accurate drives
- Innovative construction of drive belts simplifies changeovers

## Reliable Performance

- Double preformed slide unit gives stability
- Extra grip via the horizontal profile on the side belts
- Solid belt guidance

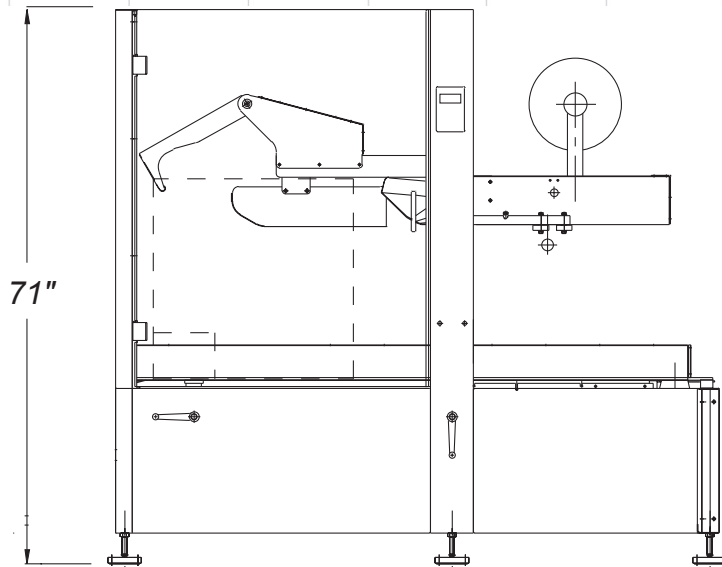

## Options

- Choice of tape
- Extra guiding
- Fixed side justification
- "Low Tape" detection
- "Broken tape" and "tape empty" signal
- Choice of color
- Signal beacon

## CS-300/1000 Specifications

### PERFORMANCE CRITERIA

- Throughput Speed Up to 25 cases per minute

### CASE SIZE

- Case Size Minimum (O.D.) 7 7/8"L x 5 7/8"W x 4 3/4"H
- Case Size Maximum (O.D.) 25 1/2"L x 17 3/4"W x 19 5/8"H

### MACHINE SHIPPING WEIGHT

- Shipping Weight (including skid) 1400 lbs.

### SERVICE REQUIREMENT

- Electric 230v, 3 phase, 15 amp, 60Hz
- Pneumatic 80 psi, clean dry air

### SERVICE SUPPORT

24 hrs/7 days a week

### WARRANTY

3 years  
 Unlimited cycles

Machine  
 Height  
 71"

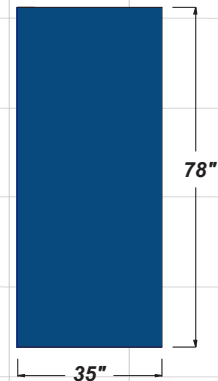

Specifications subject to change without notice. Lantech systems and sub-systems are protected by U.S. and foreign patents. Additional U.S. and foreign patents pending. © Lantech 2007

