

Principle Features

High Speed & High Flexibility

- Continuous Motion.
- Capable of running a large variety of carton dimensions and grades.
- Quick size change over with hand-wheels.
- Flexibility for cardboard grade; can run solid, flute and corrugated boards for different formats.

Clean & quiet

- Fully integrated machine guarding provides easy access to machine parts.
- Low noise level.
- Completely open lower section allows the machine to be easily cleaned.

Applications

- Carton with lid:
 - Food.
 - Confectionary.
 - Ice Cream.
 - Detergent tabs.
 - Fasteners.
 - Automotive spare parts.



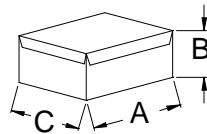
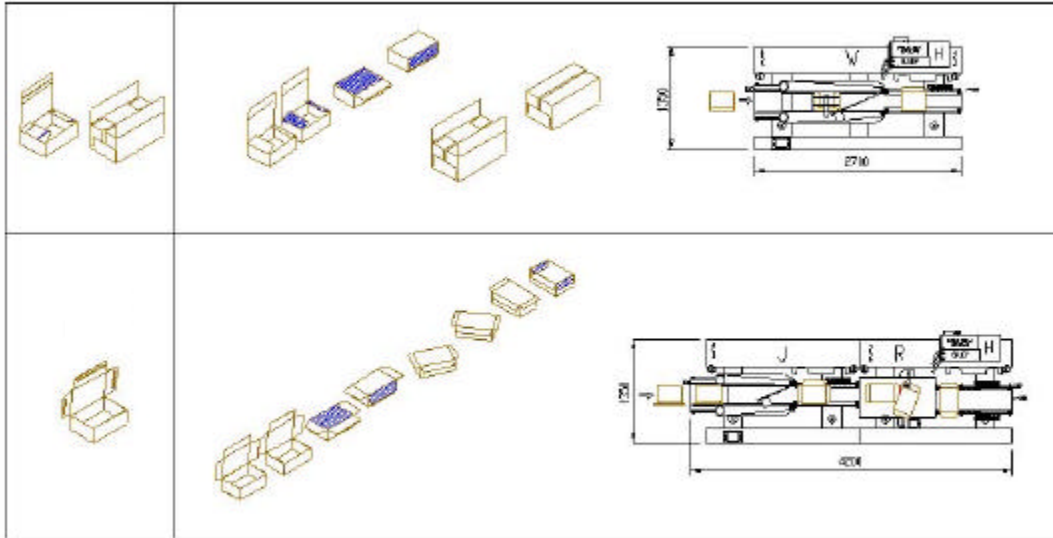

Standard Carton Sizes			
	A	B	C
MIN	100mm	100	30
MAX	400	250	150

Technical Data

All information given below is dependent upon final machine specification, feed arrangement, product type and carton specification.

Electric Consumption

380V, 400V, 415V 3PH 50HZ standard
 230V, 460V, 575V 3PH 50/60 HZ possible with power transformer control circuits 24V DC; 9 KW (typical, includes hotmelt)

Air Consumption

3 cfm (depending on option selected and speed)

Weight

Approx. 3,310 lb (1,500 kg)

Output

Up to 150 cartons/minute.

Standard Features

- PLC controls.
- Easy access to all machine parts.
- Glue closing on 1 or 3 flaps.
- Quick size change over with hand-wheels.
- Left or right handed models.

Optional Features

- Automatic size change over with PLC controlled adjustments.
- Stainless steel construction.

Packaging - Processing
Bid on Equipment
 1-847-683-7720
www.bid-on-equipment.com