



## Principal Features

### High-speed & continuous motion

- 6' extended carton magazine, fitted with pre-sized templates for quick and simple carton size changeovers.
- 2 or high-speed 5-head rotary feeder.

### Clean, quiet and hygienic design

- Wipe-down; with hose-down option.
- Stainless steel construction ideal for food packaging.
- Servo motors for carton feeding, carton transport and bucket conveyor; full separation of machine controls and drivetrain.
- Fully integrated machine guarding provides easy access to product path and machine parts.
- Fully-accessible, interlocked guarding package.

## Applications

- Bag in box:
  - Cereal.
  - Milk powder.
  - Dehydrated foods.
- Trays:
  - Ready meals.
  - Frozen food (ex. pizza).
- Pouches:
  - Flow-wrap (biscuits and confectionary, snacks).
  - Sachets.
- Speciality items:
  - Facial tissue.
  - Napkins.
  - Fem-care.
  - Air fresheners.



Dim	
A	299.21 (7600)
B	165.35 (4200)
C	245.47 (6235)
D	78.74 (2000)
E	31.49 (800)

Dimensions in inches with equivalent mm in brackets

Pitch	Standard Carton Size			
	Length	Width	Depth	
4.5"	MIN	1"	0.8	3.75
	MAX	3.3	5.1	14
6"	MIN	1.6	0.8	3.75
	MAX	4.8	5.1	14
7.5"	MIN	2	0.8	3.75
	MAX	5.9	5.1	14
9"	MIN	2	0.8	3.75
	MAX	7.4	5.1	14
10.5"	MIN	2	0.8	3.75
	MAX	8.9	5.1	14
12"	MIN	2	0.8	3.75
	MAX	10	5.1	14
15"	MIN	2	0.8	3.75
	MAX	10	5.1	14

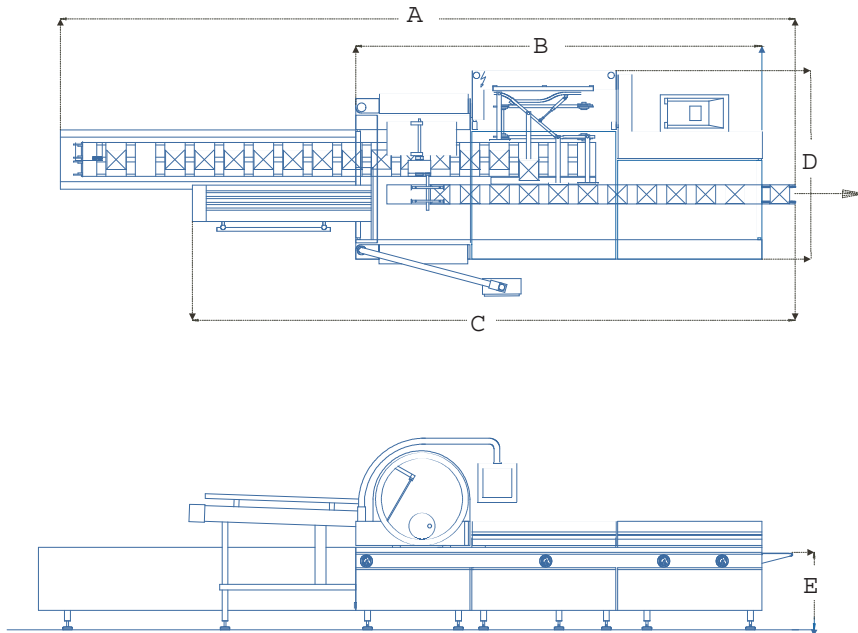

## Technical Data

All information given below is dependent upon final machine specification, feed arrangement, product type and carton specification.

### Electric Consumption

230V, 380V, 460V, 575V/3PH, 50/60 Hz (other voltages available) control circuits 24V DC, 8.5 KW (typical; includes hotmelt)

### Air Consumption

12-15 scfm/70-83 psi (depending on options selected)

### Weight

Approx. 8,820 lb. (4,000 kg)

### Output

Up to 500 cartons/minute

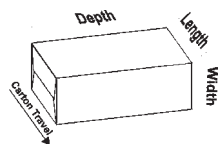

## Standard Features

- 2-head rotary feeder.
- Stainless steel construction with bevelled edges for ease of cleanliness.
- Drivetrain isolated from product flow area.
- Servo-drives.
- Carton pre-break.
- "No product/No carton/No load" feature.
- Pre-sized carton magazine templates for quick changeovers.
- Glue or tuck closure.
- Overload protection for pushers.
- Control panel on hinged arm for easy access.
- Adjustable flights to fit different product sizes.
- Rotary feeder and carton magazine adjusted with hand wheels equipped with digital counters for quick changeovers.
- In-line or 90 degree infeed.
- Cartons carried on lug chain to maximize carton surface protection.

## Optional Features

- Linear ServoPak autoloader.
- High-speed 5-head rotary feeder.
- Hose-down design.
- Open flap detect and reject.
- Emboss coding.
- Automatic carton magazine loader.
- Multi-stage feeder/collator for bags and sachets (Bomb Bay Tower style).