



## Inline 6200

Labeling System

**NEW**

The **NEW Label-Aire<sup>®</sup> Inline 6200** labeling system offers you a wealth of options and configurations to make labeling easier and faster.

The Inline 6200's sheer flexibility allows you to build a labeling system to fit seamlessly in your production line. The Inline 6200 also delivers on Label-Aire's long-standing promise of advanced features, toughness, speed, and accuracy meaning lower operating costs and increased productivity for your business.

The **NEW** advanced yet rugged Inline 6200 labeling system is a stainless steel cabinet based PLC-controlled labeling system designed for heavy duty front/back-, side panel-, or wrap labeling applications. Among its standard features are a rotating control panel, a 12 foot (3,658 mm) delrin chain conveyor with stainless steel side plates, and a segmented top trap hold down to keep your products in place. Other standard features include Automatic Speed Following (ASF) for product surface profiling, Variable Frequency Drive (VFD), and dual applicator mounts with in/out traverse, up/down, with tilt adjustments for maximum versatility. Standard speeds up to 2,000 inches (50.8 m) per minute with VFD make the 6200 the ideal choice for demanding applications requiring speed and precision. The 6200's long list of options include a choice of Label-Aire New Generation 3100/3000 Series applicators (wipe-on, air-blow, or tamp-blow), wrap belt, single or dual feedscrews, stainless steel side plates, stainless steel frame, stainless steel cabinet, airfill capability, and powered or non-powered impressors.

Put this high-speed labeling technology to work for you all day, every day. The Inline 6200 is built to meticulous quality standards and designed to work in the most hostile environments.

Have  
conta

**Packaging - Processing**  
**Bid on Equipment**

1-847-683-7720

[www.bid-on-equipment.com](http://www.bid-on-equipment.com)

# Inline 6200 Specifications

## Dimensions:

Height: 79.34" (2,015.25 mm)  
 Length: 144" (3,658 mm)  
 Width:\* 33.94" (862 mm)

## Weight:

Approx. 1,800 lbs. (817 kg)

## Standard Label Dimensions: \*\*

Max. Web Width: 7.13" (181 mm)  
 Min. Web Width: .63" (16 mm)  
 Min. Label Length: .5" (13 mm)

## Label Packaging: \*\*

12" (305 mm) O.D. rolls std. on  
 3" (76 mm) I.D. cores  
 Up to 16" (406 mm) or 20" (508 mm)  
 roll with optional 16" (406 mm)  
 non-powered rewind or  
 20" (508 mm) powered unwind

## Conveyor Speed:

Up to 2,000" (50.8 m) per minute  
 with Variable Frequency  
 Drive (VFD)

## Label Dispense Accuracy: \*\*

Up to +/- 1/32" (.8 mm)

## Electrical:

120 Volts AC 60 Hz 20 Amps.  
 220 Volts AC 50 Hz optional (CE)

## Air:

2 cfm at 60 psi to 90 psi required  
 with imprinter and/or airfill options

\*Without label applicators

\*\*Model 3115 Wipe-On specifications

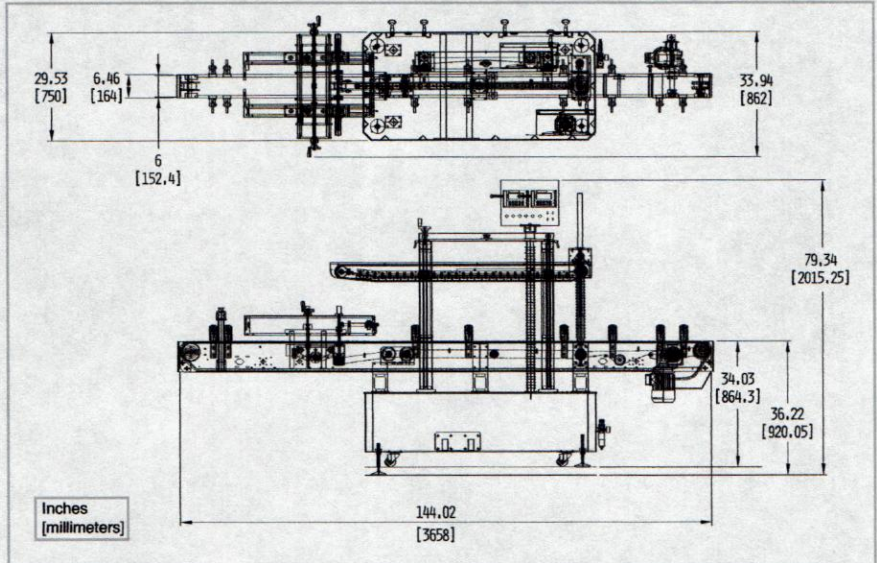

Stated dimensions are approximations. Please consult factory if dimensions are required for line integration.

<b>Main Drive:</b> Line Speed	Variable Frequency Drive (VFD) up to 2,000" (50.8 m) per minute
<b>Conveyor:</b> Width Length Height	Stainless Steel Side Plates 6.0" (152.4 mm) 12' (3,657.6 mm) center line-to-center line 36" (914.4 mm) ± 2" (50.8 mm)
<b>Applicator:</b>	Label-Aire 3100 Series Primary Applicators
<b>Operator Interface:</b> Control	Dual Keypad for Applicators, Push Button Start/Stop for Conveyor PLC
<b>Top Trap Hold Down:</b> Vertical Adjustment Belt Width Drive Airfill	Spring Segmented Blocks, Linatex Belt 16.0" (406.4 mm) 1.25" (31.75 mm) Direct Optional
<b>Feedscrew:</b> Length Options Drive Soft Start	Single or Dual 30.0" (762 mm) Direct Yes
<b>Metering Wheel (Opt.):</b> Drive	Single DC Motor
<b>Wrap Belt (Opt.):</b>	7.0" (177.8 mm) Wide x 12.0" (304.8 mm) Long
<b>Secondary Impressors (Opt.):</b> Powered Non-Powered	Available Available

Consult factory for additional options.



## Headquarters

550 Burning Tree Road  
 Fullerton, CA 92833 USA

o 714.441.0700  
 f 714.526.0300  
 e info@label-aire.com  
 w www.label-aire.com

## Europe

Sjællandsvej 27A  
 DK-9500 Hobro, Denmark

o +45.9657.0063  
 f +45.9657.0064  
 e info@label-aire.com  
 w www.label-aire.com

## Asia

No. 10, Lane 228, Taisi S. Road  
 Longjing Township  
 Taichung County 434, Taiwan

o +886.4.2395.5684  
 f +886.4.2395.8007  
 e info@label-aire.com  
 w www.label-aire.com

Distributed by

**Packaging - Processing**  
**Bid on Equipment**

1-847-683-7720

www.bid-on-equipment.com