

# KRONES Volumetric VODM

Volumetric filler for non-carbonated beverages

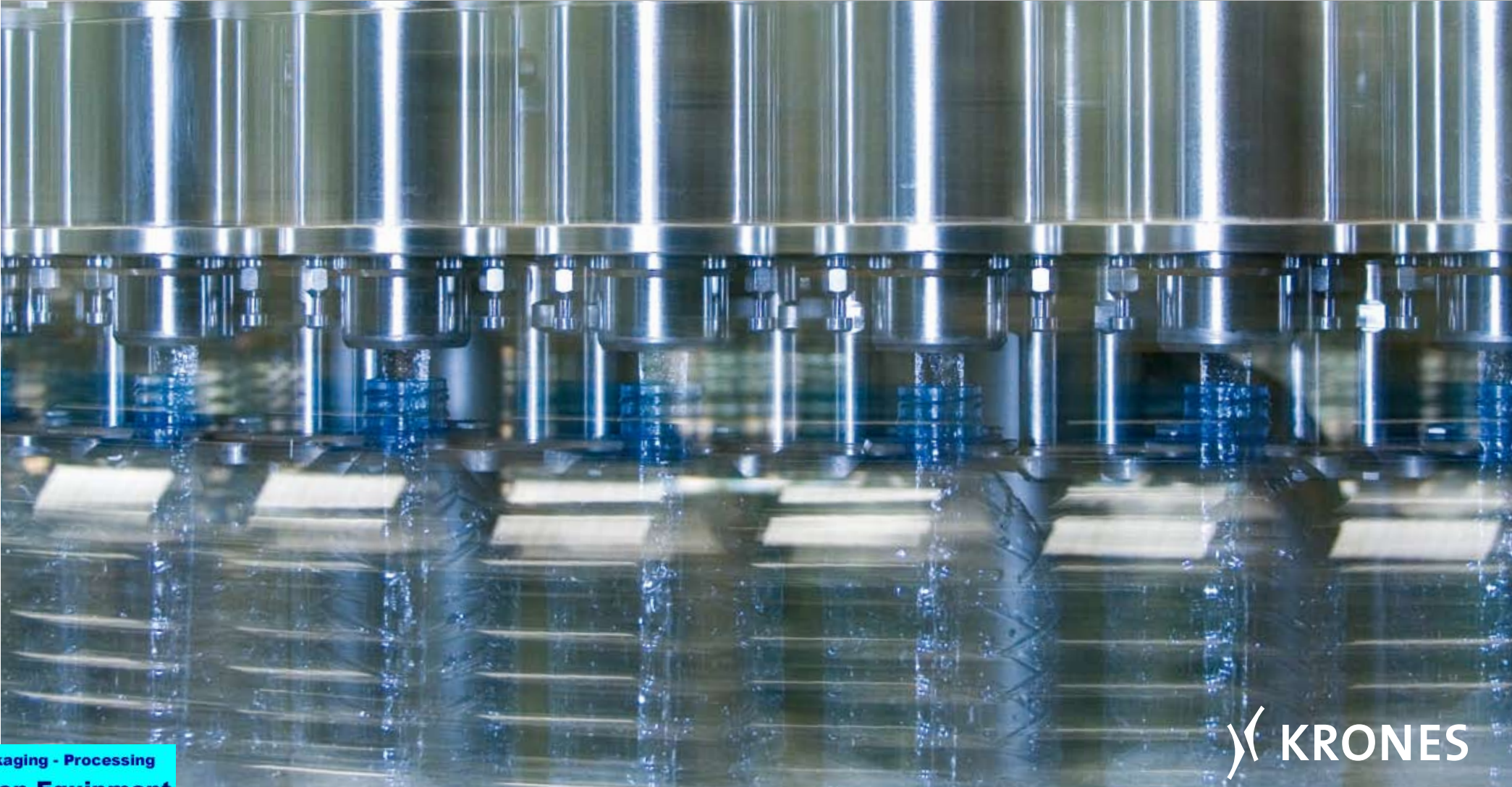

# Precise, hygienic, and flexible

KRONES Volumetric VODM

When filling non-carbonated beverages in PET containers, the fill quantity must be accurate. The Volumetric VODM series is the ideal solution for conductive products to be filled, because with this system, the fill quantity is accurately measured via an inductive flow meter. All filling process steps can be programmed easily and individually and can be performed via the electropneumatic controller adjusted to the product to be filled and to the container.

Almost all non-carbonated products such as non-carbonated mineral water, juice, coffee and tea beverages, energy drinks, or milk can be filled into PET containers using the different variants of the VODM family. The well-proven filler is distinguished by its high availability, its flexibility, and its high reliability during continuous operation. More than 600 installed volumetric fillers in more than 50 countries prove the success of the Volumetric VODM series.

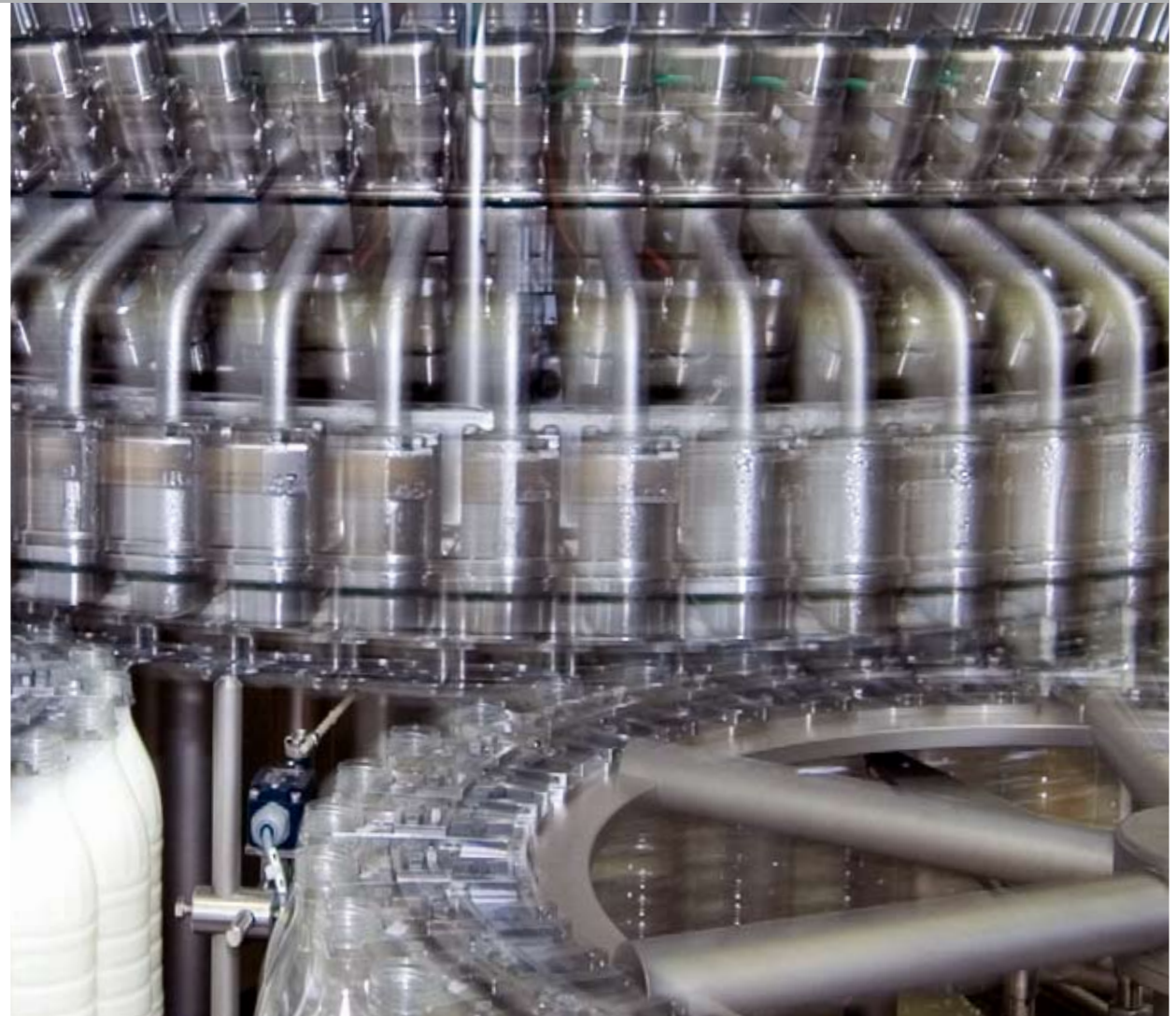

## Method of operation

Prior to filling, the product is guided to a product tank which is designed as a central or a tubular ring bowl depending on the pitch circle, and which is connected to the filling valves via the product feed pipes.

In each connecting pipe, there is an inductive flow meter which measures the quantity of the product flowing through the pipes via the product's conductivity.

Filling begins after centring or after the container being pressed-on and it is performed via the free jet method or for hot filling with pulp and fibres via swirling. In order to be able to cope with the different bottles and products to be filled, one or two filling speeds are available. Non-carbonated beverages are filled pressureless in multi-chamber operation. Once the preprogrammed amount of liquid has flown into the container, a flow meter signal will trigger closing of the valve. The fill parameters and programs are stored in the controller making quick change-overs via touch-screen selection possible. In addition to the neckhandling version, fillers with base handling feature are also available for filling containers without neck ring or HDPE bottles.

Product circulation is used for hot filling of juices and energy drinks.

## Application

Filling non-carbonated beverages in plastic bottles

## Output range

Depending on the product to be filled, this system can bottle up to 72,000 PET bottles per hour.

## Type designation

**VO** Volume

**DM** Flow metering

**PET** Polyethylene terephthalate

Model	Base-handling	Neck-handling	Water	Milk	Pulp/fibres	Hotfill	Product return
VODM-PET (40400)		X	X	X			
VODM (40318)	X		X	X			X
VODM-PET (40368)		X	X		X	X	
VODM (40316)	X		X	X	X		
VODM-PET (40363)		X	X	X	X		

Machine pitch (mm)		87	94	103	113	126	141	188	283
Type	Pitch circle diameter (mm)	Number of filling valves							
121	1,440	48	44	40		32	24	16	
122	1,800	60	55	50	45	40			
123	2,160	78	72	66	60	54	48		
124	2,520	91	84	77	70	63	56		
126	2,880	104	96	88	80	72	64		
129	3,600	130	120	110	100	90	80		
131	4,320	156	144	132	120	108	96		
132	5,040	182	168	154	140	126	112		

## Design features

- Volumetric filler
- Measuring of fill quantity via inductive flow meter
- Minimum conductivity of 40  $\mu\text{s}/\text{cm}$  required
- Gentle media feed from the bottom via media distributor and pipe joints
- Distributor and all parts contacting product or gas are made of stainless steel AIS304 or higher quality
- Quick-change, hygienic neck-handling equipment or Raptec base handling parts
- Tube ring or central bowl with optimal pre-requisite for internal and external cleaning
- Cleaning in the closed circuit via CIP cups
- New safety standards EN ISO 13849 with TÜV supervision (TÜV = technical inspection authority) completely applied
- Bloc arrangement with rinser, labeller, or blow moulder possible

*The Volumetric VODM provides a large range of sizes, outputs, and container sizes to be processed. Furthermore, special designs can be realised as well.*

■ minimum  
■ maximum

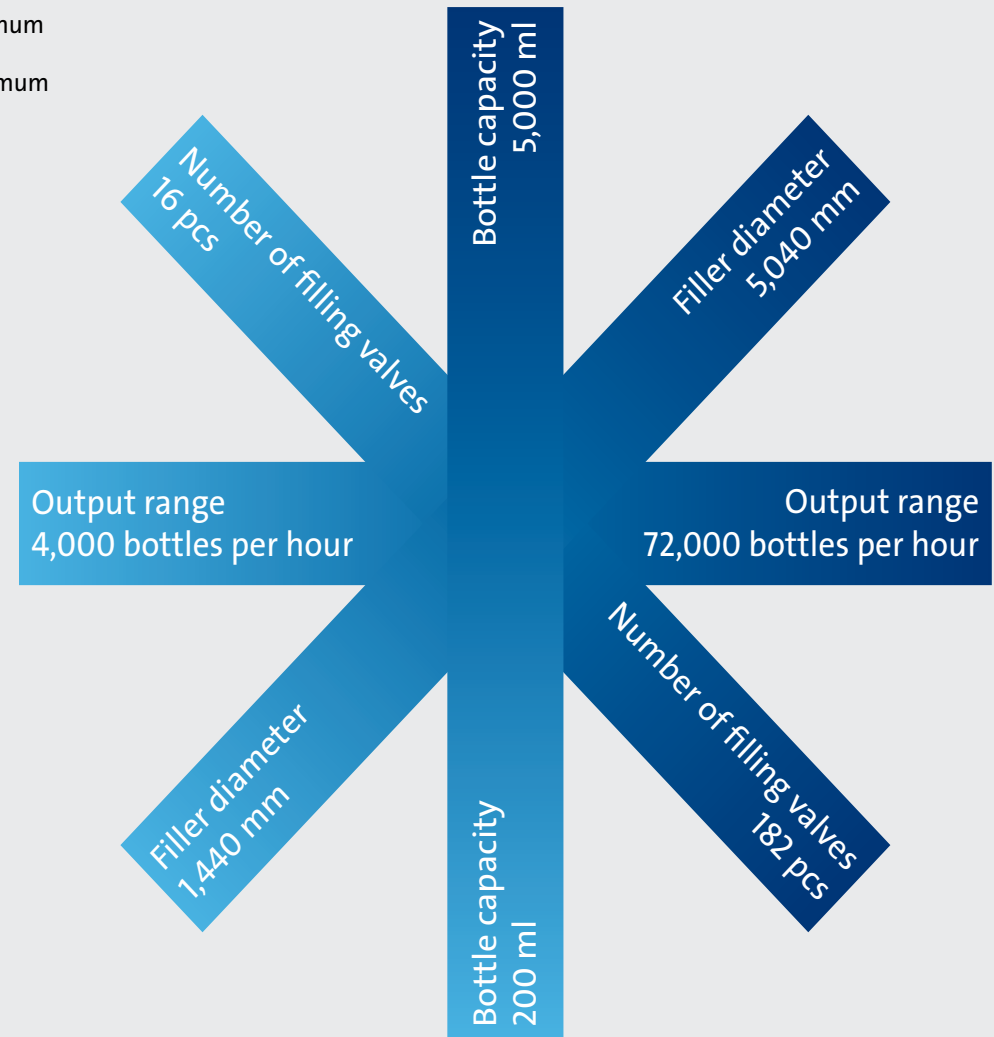

# System variants

KRONES Volumetric VODM

## VODM-PET – the basic variant

With the basic design, many products (non-carbonated mineral water, tea, and coffee beverages) can be filled non-contact and with a free jet. Thanks to its simple construction, the system can be serviced cost-efficiently.

## VODM-PET – the versatile variant:

### Cold and hot filling

This variant is used for hot filling and cold filling of juices and energy drinks. The lifting cylinder with swirl is used for filling products with pulp and fibres.

## VODM – the hygienic variant

This version is especially suitable for highly viscous products such as juices with pulp, or fibres, and milk.

VODM-PET (40400)

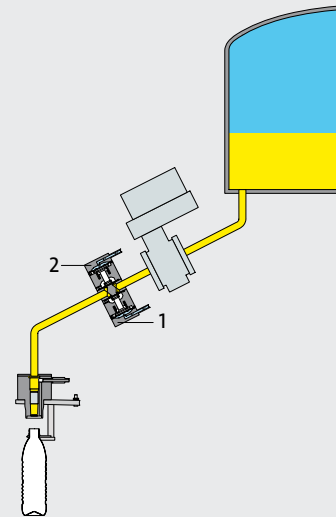

- 1 Valve, fast filling
- 2 Valve, slow filling

VODM-PET (40368)

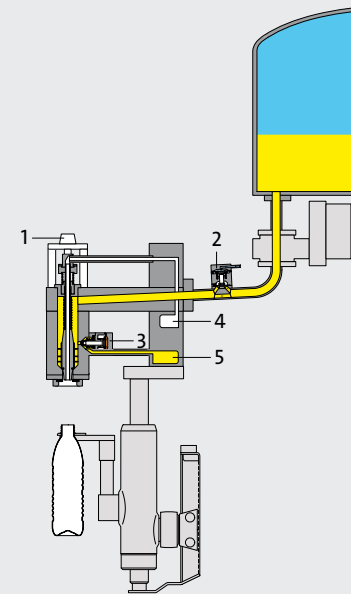

- 1 Control cylinder
- 2 Valve, fast filling
- 3 Hot return valve
- 4 Residual gas and CIP return channel
- 5 Hot return and CIP return channel

VODM (40316)

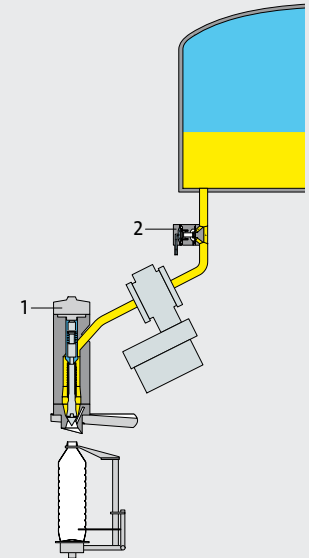

- 1 Control cylinder
- 2 Fast / slow filling

# Operation and change-over

KRONES Volumetric VODM

## Screen

- Colour touch-screen
- Safe access to the user interface through individual transponders
- User-friendly menu setup in the operating program
- Task-oriented user concept
- Easy-to-follow display of the current production data
- Filling steps can be adjusted individually and saved for any product
- Malfunction display in plain text and graphic display
- Text displayed in the set language
- Interface to superordinated systems like LDS (Line Data Storage System) or LMS (Line Management System)
- Remote maintenance possible



*Touch-screen operation*

## Change-over

- Changes of the filling volume or the filling program by touch-screen selection
- Base handling: quick replacement of the Raptec handling parts
- Neck-handling system: with the same neck-finish diameter and changes of the container height and diameter, merely the capper starwheel and lowering starwheel must be replaced



*Raptec quick-change handling parts*



*Neck-handling clamps*

# Additional equipment

KRONES Volumetric VODM

- Design with gable-type table top
- Surrounding collecting pan
- Flushing system for exterior cleaning of filler
- Fully automated valve manifold
- Measuring devices for product pipe, for example Brix value, product flow
- Consumption measurement, for example of water or nitrogen
- Spray balls in the ring bowl for optimal cleaning and quick product changes
- Product contact parts in AISI 316
- Distributor with gaskets that can be rinsed from behind or that are lubricant-free
- Product pumps
- Automatic CIP cup feed



*Volumetric VODM-PET  
with automatic CIP cup feed*

# System expansions

KRONES Volumetric VODM

- Foam cleaning system for exterior cleaning of filler
- Clean room housing with HEPA filters
- Nitrogen dropper
- Velcorin dosing



*Equipped for foam cleaning*



*Clean room housing*

# System expansions

KRONES Volumetric VODM

- KRONES Capcade – cascade sorter for caps
- Cappers from other manufacturers
- Aluminium seal machines



*Cascade sorting system  
for caps*

# Your benefits

KRONES Volumetric VODM

- **Versatility**  
This filling system is suitable for a wide range of products: from water to tea and coffee beverages all the way to highly viscous fruit juice drinks.
- **Flexibility**  
Change-over to other products or filling temperatures is done quickly, easily, and it is reproducible.
- **Short change-over times**  
Very short change-over times made possible via Raptec quick-change handling parts or neck-handling parts and changes of the filling volume via touch-screen selection or easy filling program selection.
- **Effective cleaning**  
The interior cleaning in a closed cycle, optionally with automatic CIP cup feed, enables a safe process. Smooth as well as easy-to-clean outer surfaces provide a hygienic environment.
- **Easy maintenance**  
This machine is well accessible so that all maintenance and service jobs can be performed easily.

