

KRONES Taxomatic

The machine for tax strip and lid labelling



 **KRONES**

Well-secured caps

KRONES Taxomatic

The Taxomatic is designed to apply L-shaped or U-shaped tax strips or tamper-evident seals onto containers. This machine also decorates lids of glasses and other containers with a large variety of labels. For these applications, the system can be integrated in different KRONES labellers as an additional labelling station. The Taxomatic also equips beverage cans with pre-cut foils, which serve as a hygienic protection, and at the same time, as an additional means for advertisement.



*U-shaped tax strip
(left top picture)*

*Glass containers with
tamper-evident strip
(right top picture)*

*Hygienic protection
for beverage cans
(left picture)*

Taxomatic labeller

Method of operation

With the Taxomatic, the labelling station is mounted vertically above the infeed starwheel. Directly from above, the tax strips, lid labels, or foils are transferred to the container. Labels can be glued with either cold glue, or optionally with additional hotmelt, depending on the caps and containers. After labelling, the labels are precisely pressed-on at the container table. The press-on pads of glue-repellent silicone are shaped to correspond exactly to the container's contour in the neck area, and they are controlled by a double cam in the upper section of the machine.

This system can also be integrated in the KRONES labeller as an additional labelling station Taxomat. The application of tamper-evident seals or lid labels usually takes place at a transfer starwheel, which comes after the first container table in the machine. At a second container table, labels are subsequently pressed on.

Taxomatic

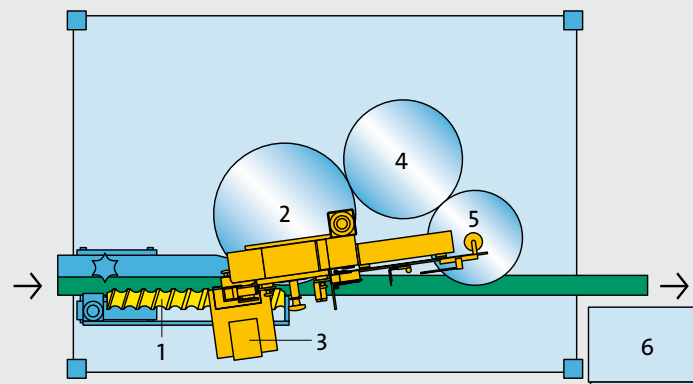

- 1 Infeed worm
- 2 Infeed starwheel
- 3 Taxomatic labelling station
- 4 Container table for tax strip or lid labelling
- 5 Discharge starwheel
- 6 Control cabinet with operator terminal

Application

- Decoration of glass containers with tax strip or tamper-evident strip or lid labels
- Application of hygiene protection to cans

Output range

The Taxomatic dresses 3,000 to 40,000 containers per hour with tax strips or lid labels and up to 60,000 cans with foil.

Prontomatic with Taxomat

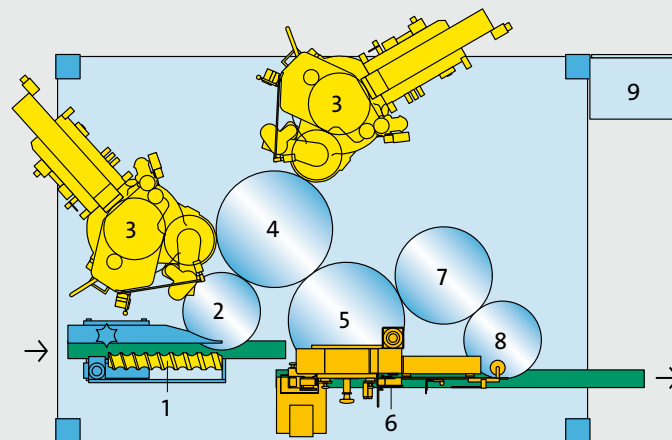

- 1 Infeed worm
- 2 Infeed starwheel
- 3 Cold-glue labelling stations
- 4 Container table
- 5 Transfer starwheel
- 6 Additional Taxomat labelling station
- 7 Container table for tax strip or lid labelling
- 8 Discharge starwheel
- 9 Control cabinet with operator terminal

Design features

- Table tops and lateral guards made of stainless steel
- Easy to change press-on pads
- Electric height adjustment of the upper machine part and the labelling station
- Quick-change Raptec handling parts
- Operating terminal with well-arranged keyboard, operating hours meter, tachometer, and mimic diagram
- Central lubrication points

Additional equipment

- Dating device for lid labelling
- Central lubrication

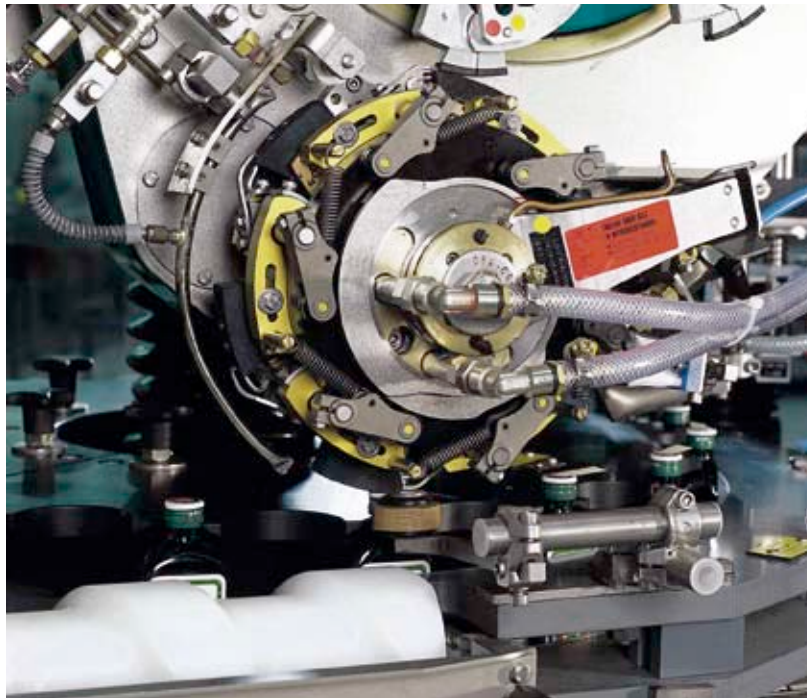

The tax strips are glued onto the container cap.



Press-on elements precisely press on the tax strips.

Your benefits

- **Precision**

Because the containers are precisely fixed during transfer, the tax strips or lid labels are applied exactly.

- **Low space requirements**

Thanks to its compact size, the Taxomatic can be easily integrated into any bottling line.

- **User-friendliness**

The Taxomatic is easily accessible and comfortable to use.

- **Time savings**

Container or label change-overs only require the briefest of conversion times.

- **Flexibility for the future**

The Taxomatic can still be retrofitted or converted, even after many years of service.

KRONES Taxomatic

