

KRONES Sleevematic

The labeller for sleeves



Sleevematic AF

The rotary machine for stretch and shrink sleeves

KRONES Sleevematic

Shrinking or stretching? The multi-talented machine can do both. The labels are pulled over the empty or full containers using an application fork. The result: Perfect sleeve position and containers attracting all the attention at the point of sale.



Sleeve transfer with the Sleevematic AF



Sleevematic AF

Figures, data, facts

KRONES Sleevematic

Method of operation

The sleeve film is unwound evenly from the reel via feed rollers and conveyed to the cutting unit via the sleeve supply unit. There, the sleeve is opened by pulling it over a mandrel. Several servomotor-controlled cutters cut the sleeves exactly to the set length. After that, the applicator pulls the sleeves over the container to their final position (figure A and B). While the applicator fork is lowered, a clamp holds the sleeve and the container tightly in place (figure C). The clamp only opens when the container has been transferred to the discharge starwheel. As a result, each sleeve is in perfect position and cannot slip.

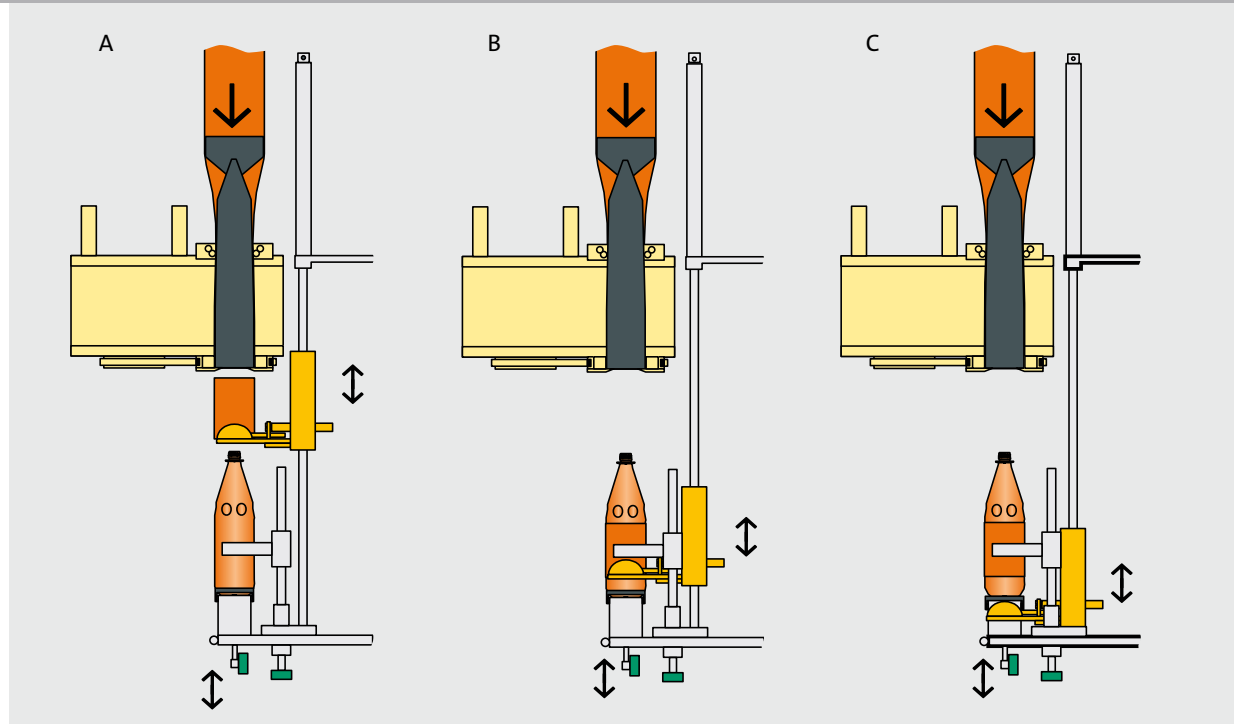

Sleeve transfer with the Sleevematic AF

Application

Sleeve labelling of glass and plastic containers (empty and full) for stretch and shrink sleeves.

Output range

Depending on the length of the sleeves, the machine can label 3,000 to 50,000 containers per hour.

Sleevematic AF

Figures, data, facts

KRONES Sleevematic

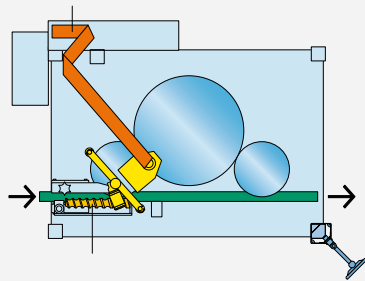

Linear arrangement

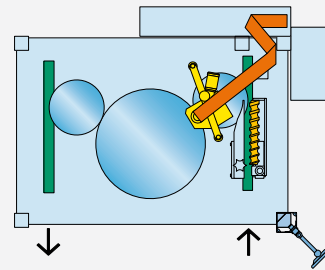

Parallel arrangement

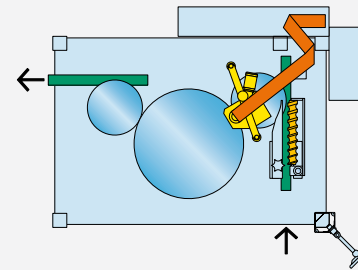

Angular arrangement

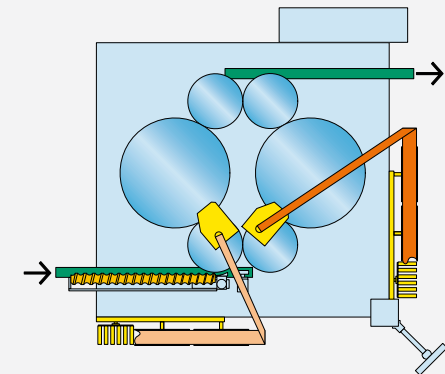

Sleevematic AF with two container tables

- 1 Infeed worm
- 2 Infeed starwheel
- 3 Container table
- 4 Sleeve reel
- 5 Cutting unit
- 6 Discharge starwheel
- 7 Control cabinet
- 8 Touch-screen

Design features

- Electronic cap inspection and gap detection at machine infeed
- Infeed worm equipped with safety clutch
- Feeding of sleeves by means of two sleeve reels
- Sleeve supply for reel change
- Height-adjustable cutting unit with sleeve conveyor
- Standard machine PLC
- Electronic container counter
- Integrated, ready-to-connect control cabinet
- Central lubrication points
- Optional with the automatic reel-fed magazine Multireel S

Additional equipment

- Coding with ink-jet or laser printer
- Mechanical container orientation system for special dressings
- Hot-air nozzles for pre-positioning of sleeves
- Device for longitudinal and transversal perforation of sleeves
- Clamping starwheels at the infeed and discharge for the handling of different containers with a difference in diameter of up to 20 mm
- Additional container and sleeve sets
- Central lubrication

Sleevematic M

The inline machine for shrink sleeves

KRONES Sleevematic

You have something special in mind for your product decoration? Then the Sleevematic is the perfect decision. Because the specialist for shrink sleeves even labels special shapes quickly, cleanly, and reliably. Being a modular inline machine, it can easily be adjusted to any production speed!



Sleeve transfer with the Sleevematic M



Sleevematic M

Figures, data, facts

KRONES Sleeveomatic

Method of operation

Unwinding and cutting of the film sleeve is performed just like with the Sleeveomatic AF. After cutting, a feed applies the open sleeves directly to the container. Depending on the container shape and the sleeve size, an optional positioning module moves the sleeve to the desired position. Partial sleeves will be moved to their exact position by means of lateral guides. Optional hot-air nozzles shrink and pre-position the sleeves. After that, the sleeves are shaped perfectly around the container contour in a steam or hot-air tunnel.

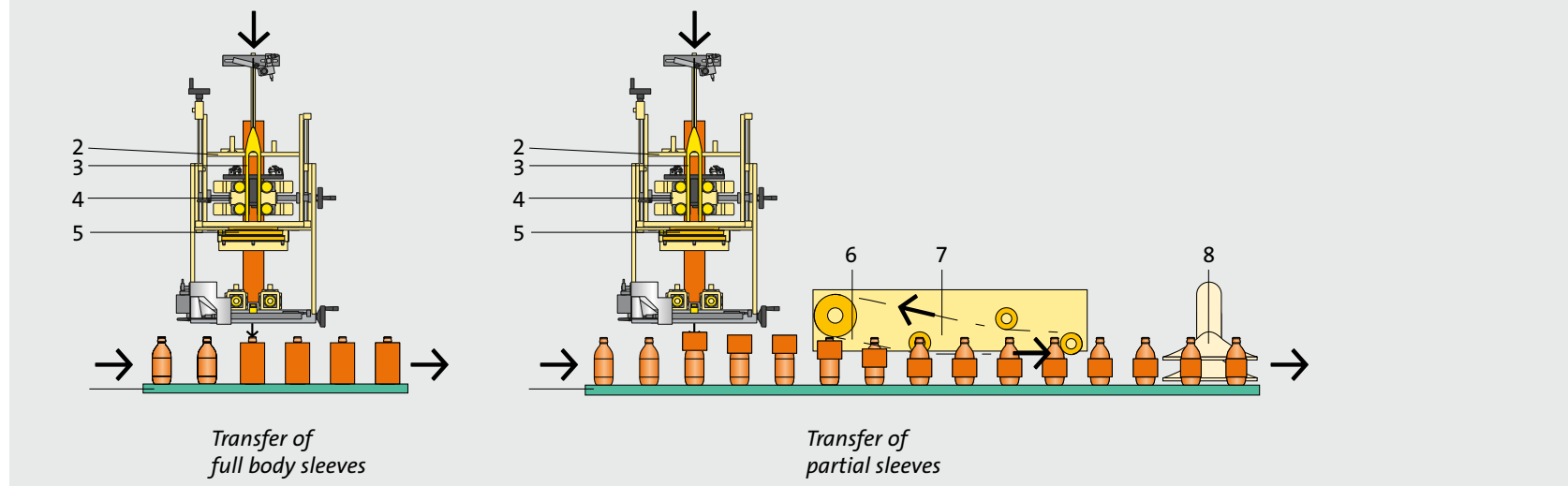

Design features

- Electronic gap detection at machine infeed
- Infeed worm with servodrives
- Sleeve feed via free-standing sleeve buffer
- Sleeve supply unit for reel change without machine stop
- Height-adjustable cutting unit with sleeve conveyor
- Standard machine PLC
- Integrated, ready-to-connect control cabinet

Application

Labelling with shrinkable full body and partial sleeves

- 1 Container infeed
- 2 Suspension for the cutting unit (height-adjustable)
- 3 Mandrel
- 4 Sleeve transport-unit
- 5 Sleeve cutter unit with servo-controlled, rotating blades
- 6 Lowering belt
- 7 Device for positioning of the sleeves (optional)
- 8 Hot-air nozzles for pre-shrinking (optional)

Sleevematic M

Figures, data, facts

KRONES Sleevematic

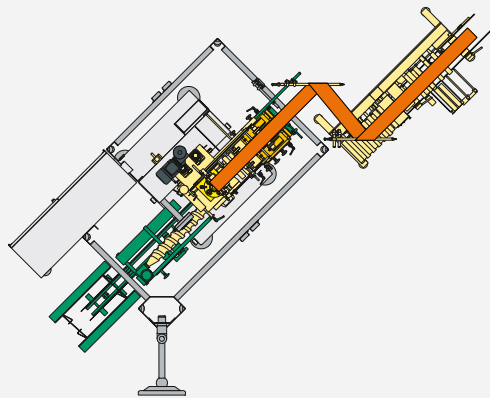

Sleevematic M1 with one cutting unit

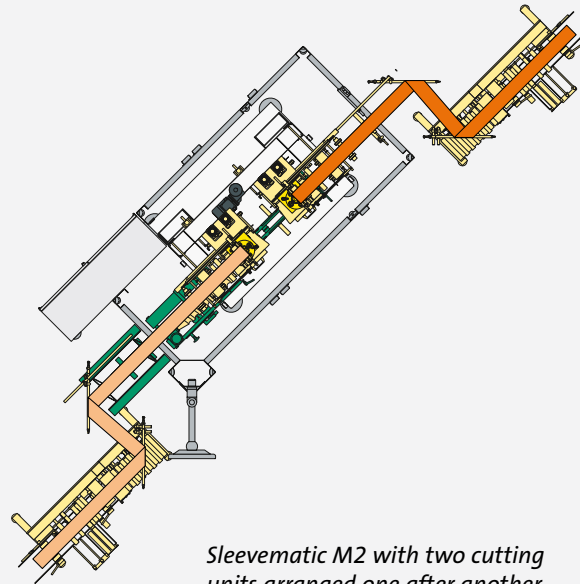

Sleevematic M2 with two cutting units arranged one after another

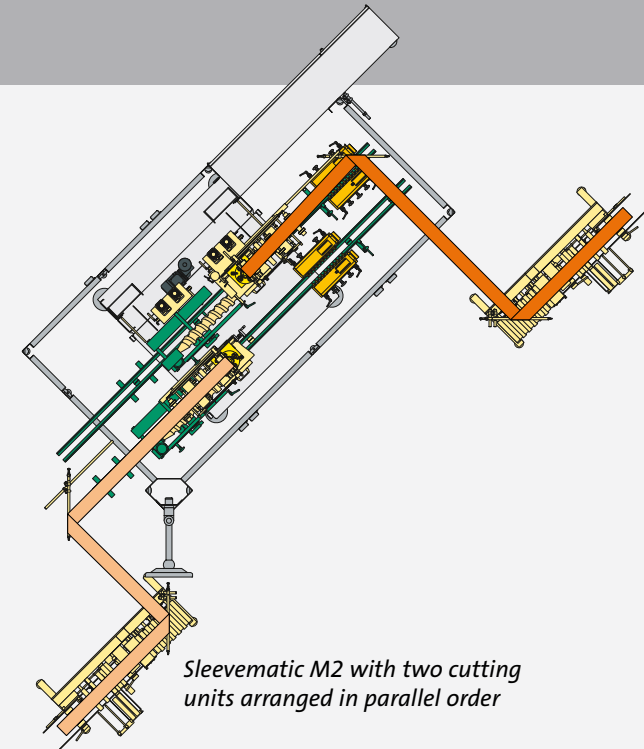

Sleevematic M2 with two cutting units arranged in parallel order

Output range

The output of the machine depends on the number and layout of the cutting units. You can choose between three different designs:

- Version M1 labels up to 27,000 containers/h.
- Version M2 increases the machine output to up to 40,000 containers/h.

- Version M2 parallel allows a maximum output of 54,000 containers/h.

The indicated outputs apply to a sleeve length of 150 mm.

Additional equipment

- Manually adjustable positioning module for partial sleeves
- Hot-air nozzles for shrink-fitting and pre-positioning of sleeves
- Equipment for longitudinal and transversal perforation of sleeves

Sleevematic Operation and change-over

KRONES Sleevematic



Screen

- Colour touch-screen
- User-friendly menu setup in the operating program
- Safe access to the user interface through individual transponders
- Easy-to-follow display of the current production data
- Malfunction display in plain text and graphic display
- Text displayed in the set language
- Interface to superordinated systems such as PDA (production data acquisition) or LMS (line management system)
- Remote maintenance possible



Change-over

The Sleevematic can be changed to another container or sleeve size within a very short time. For the Sleevematic AF, the fastest possible change-over takes 15 minutes; for the Sleevematic M, the change-over takes 30 minutes. To do so, the new type will be selected first on the touch-screen. When new containers or sleeves are to be used for the first time, all sleeve parameters can be programmed and stored via menu prompts. The height adjustment of the cutting unit is motor-driven.



Reel change

During the reel change-over, the end of the first reel is spliced to the beginning of a new reel. Thus, the need to thread the sleeve into the machine at each change-over is eliminated. A cutting table that is mounted at the sleeve magazine significantly facilitates this task. Due to the generously dimensioned sleeve supply unit, reel change-over can be carried out without interruption of production. The additionally available magazine Multireel S offers space for up to eight sleeve reels, which are bonded to each other automatically – without any reduction in the output.



Sleeve supply unit with cutting table

System expansions KRONES Shrinkmat – modular steaming tunnel

KRONES Sleeveomatic

- Can be expanded at a later point when needed
- Convinces through compact design with integral steam pipe system
- Easily accessible through lateral doors
- All settings can be reproduced via adjustable nozzle bar
- Connection for steam extraction
- Each tunnel zone has its own temperature display and temperature control
- Safety switch at every door for interrupting the steam supply



System expansions

KRONES Checkmat – Versatile inspection unit

KRONES Sleevevatic

- Checks the position of the sleeves
- Identifies the labels
- Checks printed data (optical character recognition via OCR/OCV)
- Recognises bar codes
- Checks fill level and container cap
- Reliable discharge of faulty containers via clamping starwheel or pusher



System expansions

KRONES Multireel S – Automatic sleeve magazine

KRONES Sleevevatic



- Takes up to eight sleeve reels simultaneously (for a label width of 50 – 145 mm)
- Enables the Sleevevatic to work autonomously for up to 8 hours – without the intervention of an operator
- Splices sleeve reels automatically – without any reduction in the output
- Can be retrofitted easily in already installed sleeve machines
- Convinces through space-saving and ergonomic design
- Special design for sleeve widths of up to 200 mm and 6 sleeve reels possible

Output

- Up to 30,000 containers per hour

Your advantages

- **Glue-free labelling**
Labelling with sleeves takes place without any glue application.
- **High performance**
The different variants of the Sleeveomatic M allow precise labelling in all speed ranges.
- **User-friendliness**
The Sleeveomatic is easily accessible and comfortable to use.
- **Time saving**
Container or sleeve changeovers require very short conversion times.
- **More space**
Due to its compact design, the Sleeveomatic M requires little space for installation.
- **Precise sleeve cut**
The rotating cutting technology of the Sleeveomatic ensures a precise cutting result.
- **Saving**
For the opening of the sleeve, the Sleeveomatic does not require an additional vacuum unit.
- **Relief for the operators**
With the additionally available magazine Multireel S, the Sleeveomatic works entirely autonomously for up to eight hours.

