

# KRONES Linapac II

## Fully automatic packing machine



# In or out?

KRONES Linapac II

Packing, unpacking, sorting, orientation – the Linapac II packing machine is highly versatile. It can handle a wide variety of packing and unpacking tasks and process many different kinds of containers.

Its great adaptability, with a modular design permitting multiple layout configurations, means it is easily integrated into existing lines.

The machine itself is remarkably easy to use in everyday operations. The lifting unit and horizontal axis are fitted with maintenance-free toothed belts. Format change-over is partially or even fully automatic depending on model. And because it is easy to see into and to access, it makes all operator control and maintenance tasks easy too.



## Method of operation

The Linapac II packing machine is an intermittent motion machine and can be used as a packer, an unpacker, or a combination of both.

For packing, the containers enter on one or more container table and are then distributed to lanes. Then packing heads grab the containers, move them to the packing position and place them in the waiting empty packs.

The packing cam is easily programmable, as the drives of the lifting unit and horizontal axis are controlled independently. This means different positions can be set within the operating range. The precision control system ensures accuracy of movement to within a milli-metre, combined with gentle start-up and braking.



## Application

- Packing and unpacking top-side open packs
- Processing of cylindrical containers as well as specially shaped glass and plastic containers
- Empties sorting

## Design features

- Modular design
- Lifting unit and transverse conveyor with toothed belt
- Single-lane or double-lane pack conveyor
- Free-standing operator panel with touch-screen
- Programmable logic control
- Driven by frequency-controlled motors
- Lifting unit with maintenance-free toothed-belt drive
- Lifting unit safety stop feature
- Easily exchangeable linear guides on the lifting unit
- Machine protection with protective grating and sliding door

## Additional equipment

- Free-flow transition at infeed table
- Motorised adjustment of guide plates in the container infeed
- Crank-adjustable pack conveyor rails
- Sensor to position labels for optimum promotional impact
- Shelf, drum or flat storage of handling parts sets
- Handling parts trolley
- Fully automatic handling parts change-over system
- Flap opener
- Connection to production data acquisition system

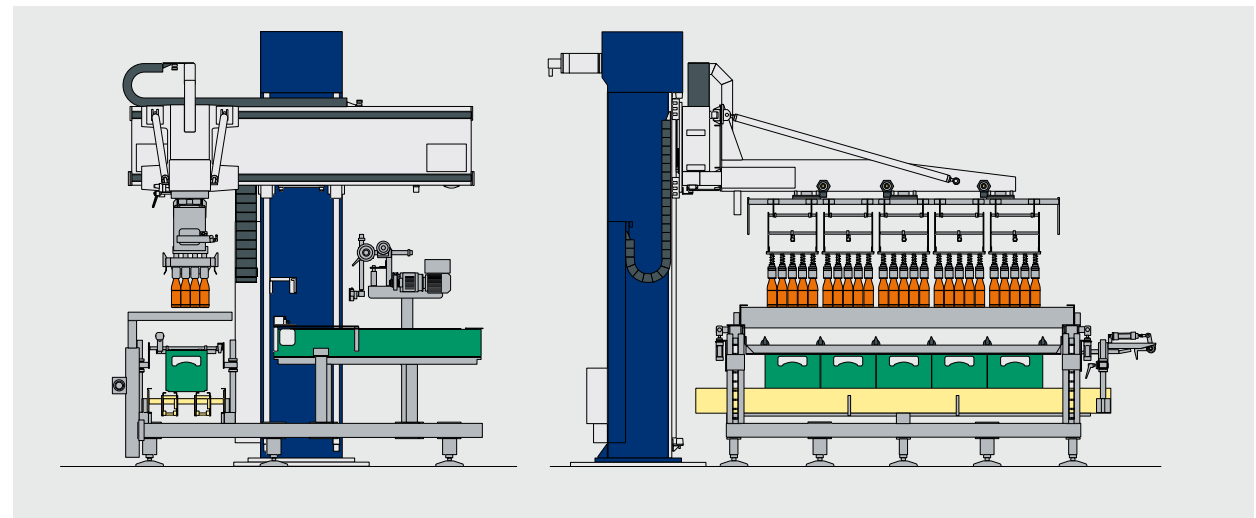

Size	Pack block length (mm)	Output (per hour)			Output (per hour)		
		Single-lane		Double-lane			
		Unpacker	Packer	Unpacker	Packer		
		Plastic crates	Cartons	Plastic crates	Cartons		
1600	1.600	560	520	460	460	440	380
1800	1.850	550	500	440	440	420	370
2200	2.100	530	480	420	420	400	360
2500	2.450	500	450	400	400	380	350
2900	2.900	470	420	380	380	360	340

## Layout configurations

The Linapac II is available in different sizes and can be adapted to a wide range of output requirements. The individual models merely differ in their container table width and pack conveyor length. KRONES offer different layout configurations precisely tailored to your needs. They include the following standard configurations:

- T configuration for round containers
- H configuration for specially shaped containers and multipacks
- HT configuration, optionally for round containers or multipacks

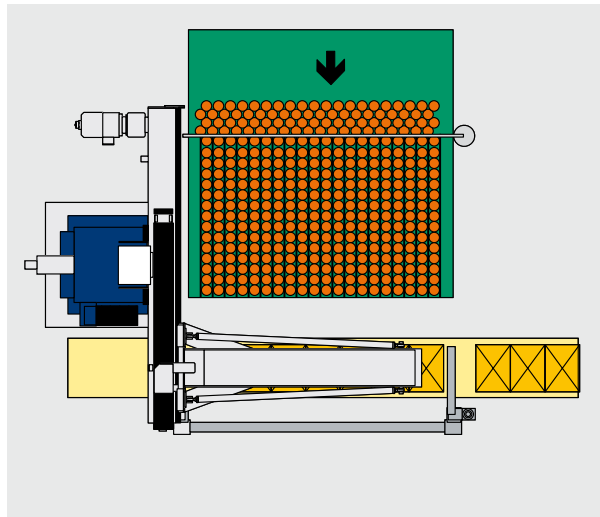

*T configuration*

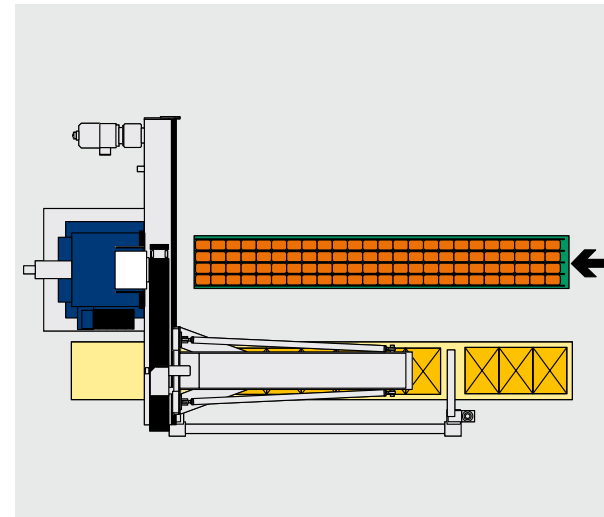

*H configuration*

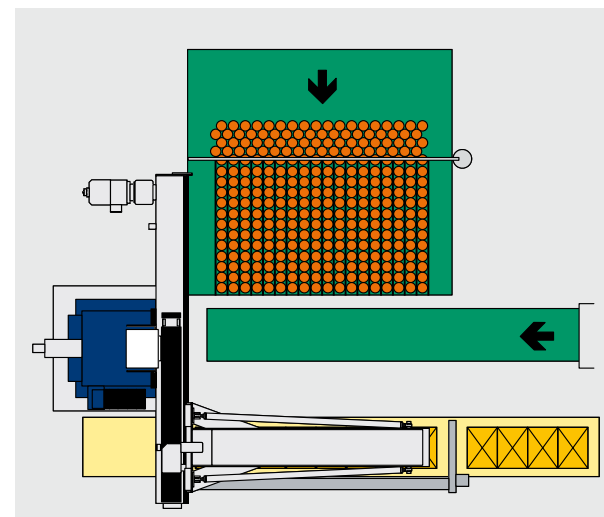

*HT configuration*



## Container infeed and discharge

- Container table with bumper, vibrator and quantity monitoring unit
- Container transport optionally by flush grid belt or steel/plastic flat-top chain
- Infeed drive by three-phase motor with separate frequency inverter for infinitely adjustable infeed speed
- Container conveyor transition with transfer plate



## Pack spacer

- Pneumatically operated
- For plastic crates: safe placement from above
- For cartons: pack-protecting placement from the side

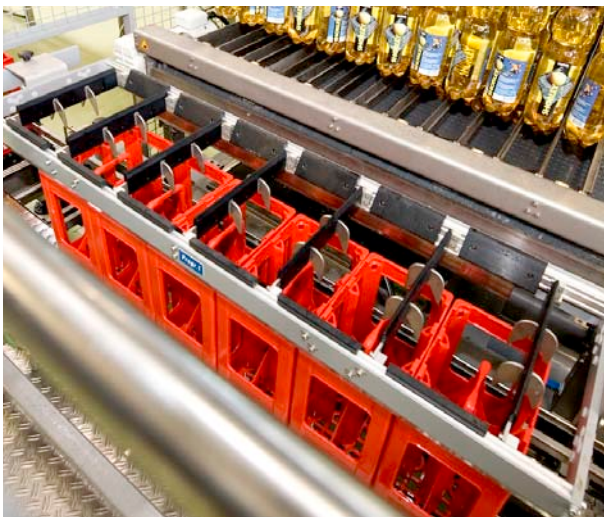

## Pack conveyor

- Robust steel flat-top chain
- Infeed and pack stopper for gentle pack stopping
- For four packs or more: spacing stopper for safe handling
- Frequency-controlled drive for infinitely adjustable speed
- Rail adjustment manually or optionally by crank

## Gripper

Different variants of the gripper head and gripping units are available depending on the packing task to which the Linapac II is assigned.



*Rigid gripper head for removing glass bottles from returnable packs*

## Gripper heads

- Rigid gripper head for unpacking
- Gripper head with one-dimensional or two-dimensional packing movement
- Spindle-adjustable gripper head for handling different container diameters
- Special gripper head with container orientation function



*One-dimensional, flexible gripper head for precise insertion into packs*



*Spindle-adjustable gripper head for handling different container diameters*



## Gripping units

- Standard gripper cup for processing of containers of different size and contour
- Long-life gripper for processing of containers with crowns
- Gripper cups for PET containers with centring using moveable outer sleeve and with mechanical hook gripper head
- Special gripper with suction cups or mechanical grippers for multi-packs or specially-shaped containers

## Operation

- Touch-screen
- Clear display of operating data, operator control functions, graphical status display, help texts and diagnostic tools
- Texts displayed in the selected language
- Password-protected access

With fully-automatic handling parts change-over, the connections are unlocked by robot couplings and no intervention by the operator is necessary. Further alternatives for bottle size change-over are a separate drum magazine, a flat magazine, or a handling parts trolley.

## Change-over

The handling parts can be changed quickly, easily and safely with a shelf magazine:

- Handling parts lock release without use of tools
- Automatic positioning of the gripper head carrier in front of an empty handling parts storage position
- Motorised transfer of handling parts into the storage area
- Automatic transfer of gripper head carrier to the position of the new handling part
- Motorised pushing of the new handling part to the carrier
- Handling part and compressed air connection are locked in position by operator



*Fully automatic handling parts change-over*

# Your benefits

KRONES Linapac II

- **Flexible application options**

The versatile Linapac II can be used for both packing and unpacking containers. It can also handle combined packing and unpacking as well as sorting tasks with ease.

- **High degree of functional reliability**

The robust design of all units and components ensure safe, trouble-free operation of the packer.

- **Low space requirement**

Thanks to its compact dimensions, the Linapac II can also be installed without problem in small spaces.

- **Wide processing range**

The wide variety of available gripper heads means many different container types can be safely processed.

- **Fast change-over**

Based on extensive automation, changing to different formats is quick and easy. The Linapac II can optionally also change format fully automatically.

