

## KRONES Isofill VV

The dependable vacuum filling system



 **KRONES**

# Filling without losing a precious drop

KRONES Isofill VV

A simple way to fill wine, liqueurs or spirits is to use the filler Isofill VV. The mechanically controlled filling system uses the principle of gravity - the product to be filled simply flows from the ring bowl into the bottle because of the difference in the height. The design for of the filling system is adapted to the properties of the particular product. Thus for example, the cross-sections of the filling valve are accordingly modified for optimum flow behaviour of thin or thick-bodied beverages. Not only this, the fill level is reached exactly by vacuum correction with product return - in this way not a drop of the valuable beverage is lost.



*Vacuum filling system for spirits in specially shaped bottles*

# Figures, data, facts

## Method of operation

The ring bowl is filled with the product using the bottom filling process. The level of liquid is controlled here by means of probes. The filling process starts when the lift cylinder presses the bottle against the centring bell and the filling valve. The bottle thus raises the filling valve against the force of the external pressure spring to thereby open the feed from the ring container. The return air displaced from the bottle escapes through the vent tube into the ring container. Air from the bottle can no longer escape into the ring bowl once the level of liquid has reached the filling tube. The exact amount of surplus product is returned to the ring bowl by adjusting the vacuum. Only a pressed-on bottle is evacuated ("no bottle no vacuum"). The suction volume flow is kept to a minimum for gentle product handling. The filling valve closes as the lifting unit lowers the bottle away from the filling valve. Operation of the filling valve is controlled by mechanical means only. Every type of media – i.e. the product, cold or hot water, or steam – can be fed automatically through the easily accessible valve manifold arranged next to the filler.

## Application

Filling wine, liqueurs or spirits in glass bottles

## Output range

Depending on the product to be filled, the system can fill up to 60,000 bottles per hour.

## Type designation

**V** Valve

**V** Vacuum

**CIP** Cleaning in Place

| Model          | Glass | Clear spirits | Liqueurs | Still Wine | No bottle no vacuum | Correction | Vacuum | CIP |
|----------------|-------|---------------|----------|------------|---------------------|------------|--------|-----|
| VV (50105)     | X     | X             |          |            | X                   | X          | X      |     |
| VV (50120)     | X     | X             | X        | X          | X                   | X          | X      |     |
| VV-CIP (50110) | X     | X             |          |            | X                   | X          | X      | X   |
| VV-CIP (50130) | X     | X             | X        | X          | X                   | X          | X      | X   |

| Machine pitch |                            | 87                       | 94 | 103 | 113 | 126 | 141 | 188 | 283 |
|---------------|----------------------------|--------------------------|----|-----|-----|-----|-----|-----|-----|
| Type          | Pitch circle diameter (mm) | Number of filling valves |    |     |     |     |     |     |     |
| 121           |                            |                          |    |     |     |     |     |     |     |
| 122           | 1,440                      |                          | 48 | 44  | 40  |     | 32  | 24  | 16  |
| 123           | 1,800                      |                          | 60 | 55  | 50  | 45  | 40  |     |     |
| 124           | 2,160                      | 78                       | 72 | 66  | 60  | 54  | 48  |     |     |
| 126           | 2,520                      | 91                       | 84 | 77  | 70  | 63  | 56  |     |     |

## Design features

- Valve control using the bottle
- Vacuum channel for fill level correction
- Only a pressed-on bottle is evacuated (“no bottle no vacuum”)
- Gentle feed of medium from the bottom by means of rotary media manifold and pipe joints
- Manifold as well as all parts coming into contact with the product or gas are made of stainless steel tool steel AISI 304 grade or higher
- Quick-change Raptec handling parts in hygiene design
- Cleaning in the closed system by using CIP cup storage (for Isofill VV-CIP)
- Latest safety requirements of the standard EN ISO 13849 have been implemented under supervision of TÜV technical inspection authority
- Up to three cappers can be integrated
- Block arrangement with rinser or labeller possible

*The Isofill VV series offers a wide range of sizes, output and container sizes for processing. Furthermore, customised versions can be realised as well.*

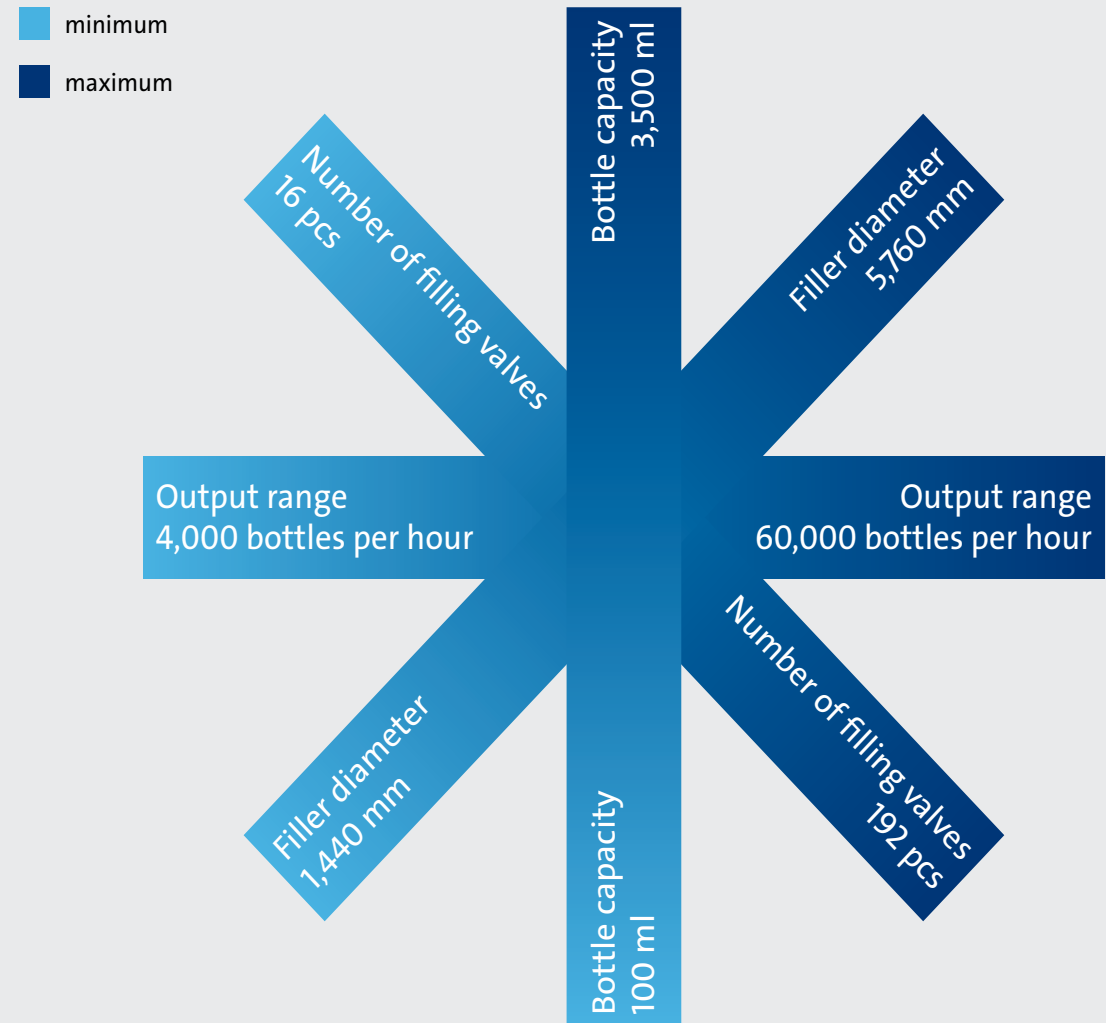

# System variants

KRONES Isofill VV

## VV - the variant for spirits

Clear, low-viscosity and sugar-free spirits can be filled using this variant in a way which is gentle on the product.

## VV - the variant for wine and for liqueurs

With this variant the product to be filled does not flow into the bottle by way of the centring bell and neck finish but rather through a filling tube.

## VV-CIP - the variant for wine and for liqueurs (CIP-able)

With this variant the product to be filled does not flow into the bottle by way of the centring bell and neck finish but rather through a filling tube. The system also has a closed CIP circuit.

VV (50105)

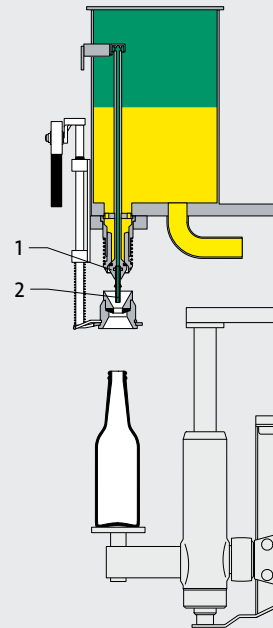

- 1 Valve stem
- 2 Vent tube on the inside

VV (50120)

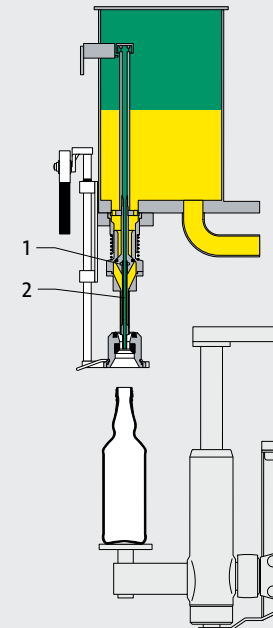

- 1 Valve stem
- 2 Filling tube with vent tube on the inside

VV-CIP (50130)

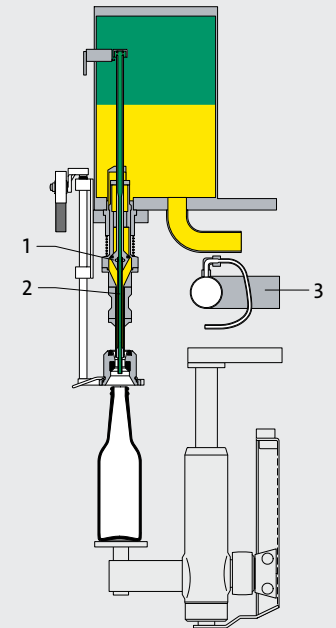

- 1 Valve stem
- 2 Filling tube with vent tube on the inside
- 3 CIP channel

## Screen

- Colour touch-screen
- Safe access to the user interface from separate transponders
- User-friendly menu guidance through the operating programme
- Task-orientated operating concept
- Easy-to-follow display of the current production data
- Filling steps can be set and saved individually for each product
- Malfunction display in plain text and graphic display
- Text displayed in the selected language
- Interface to higher-level systems like LDS (Line Data Storage System) or LMS (Line Management System)
- Remote maintenance possible



*Touch-screen operation*

## Change-over

- Change-over to a different fill level by changing the vent tube or the spacers
- Automatic adjustment of the height for the ring container and the capper
- Replaceable centring bells for different neck finish shapes
- Quick-change Raptec guidance handling parts



*Raptec quick-change handling parts*

# Additional equipment

KRONES Isofill VV

- Fully automatic valve manifolds
- Parts in contact with the product are made of tool steel AISI 316
- All parts coming into contact with the product are passivated
- Manifolds with seals which can be rinsed from all sides or do not smear
- Product pumps
- Lift cylinder of oil-free design
- Dry-running cam rollers
- Two-step automatic adjustment of the vent tube for changes in the fill level



*Fully automated  
valve manifold*

# System expansions

KRONES Isofill VV

- Clean room housing with HEPA filters
- Extraction system
- Cappers from other manufacturers



*Clean room housing*

# Your benefits

KRONES Isofill VV

## ■ Exact fill level

Because of the vacuum correction the system reaches the defined fill level with high accuracy.

## ■ High product quality

The high-grade products to be filled are handled gently because the suction volume flow from the vacuum is only minimal.

## ■ Flexibility

Any change-over to other products or filling temperature is quick, straightforward and reproducible.

## ■ Short change-over times

Raptec quick-change handling parts, quick exchange of the vent tube and easy selection of the filling programme make extremely short change-over times possible.

## ■ Easy maintenance

Access to the machine is simple so that all maintenance work and service jobs can be carried out easily.

