

KRONES Aircontronic Contamination detection systems



Contamination detected, hazard eliminated

KRONES Aircontronic

Empties regularly include bottles which are no longer suitable for re-use. This is either because they contain hazardous substances which cannot be washed out or because the dirt they contain would contaminate the caustic of the washer and so render it unusable.

The inspectors of the Aircontronic series detect these “black sheep” by their odour and sort them out safely from the “herd” of empties. This eliminates any health risk to your customers and prevents production line breakdowns.



Aircontronic Compact – hygienic design with a sensitive “nose”

KRONES Aircontronic

On average, one returnable PET bottle in a hundred contains substances which cannot be removed by the washer. The Aircontronic Compact inspector reliably detects them. To do so, it uses a state-of-the-art mass spectrometer. The machine itself conforms to all the requirements of hygienic design. As a result, dirt deposits have no chance – and cleaning can be completed in a trice!



Aircontronic Compact Figures, data, facts

KRONES Aircontronic

Method of operation

The inspector is installed directly on the single-lane conveyor. A two-stage non-contact vacuum pump system takes a gas sample from the bottles as they pass by. The sample is ionised in a quadrupole mass spectrometer and routed by way of electromagnetic fields to a detector. There it is sequentially broken down by molecule mass in order to quantify the various masses.

In order to identify liquids with no gas phase as well, the inspector can additionally be equipped with a CCD camera. The camera analyses the residual liquids in parallel to the detector based on their colour and also scans the container floor for extreme dirt contamination.

Any contamination detected is evaluated on an industrial PC. If a container exceeds the limit values defined for it, it is immediately rejected.

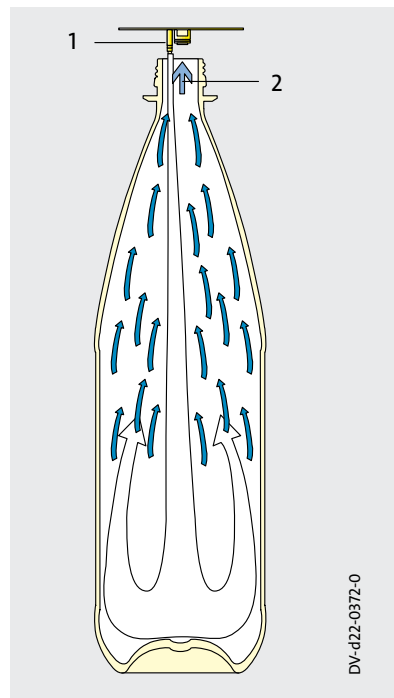

- 1 Neutral air is blown into the container.
- 2 The mixture of air and gas is drawn off and examined for contaminations.

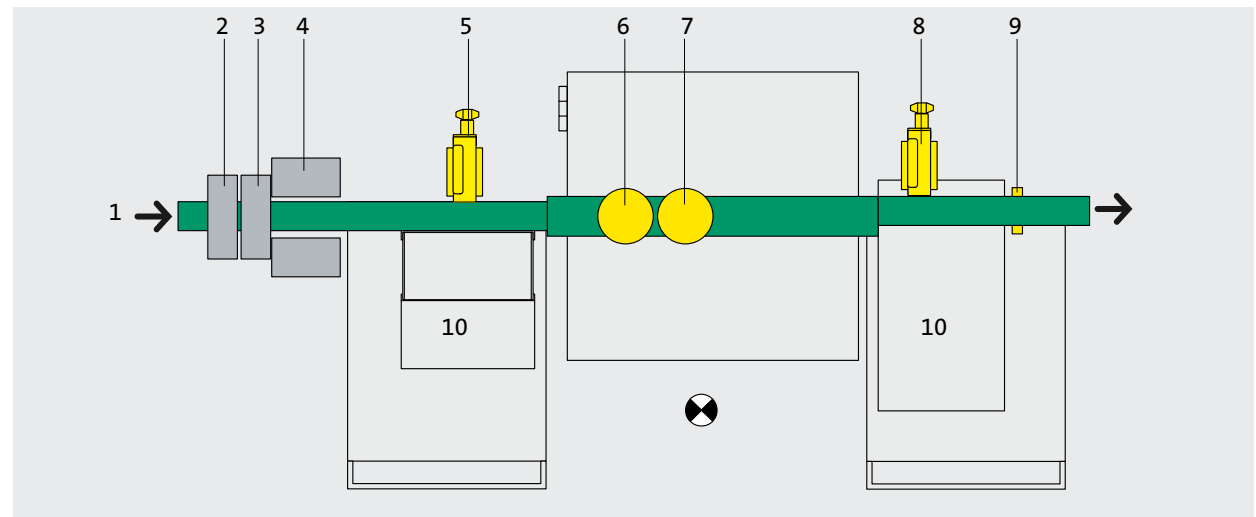

Layout of a fully equipped
Aircontronic Compact

Application

Detection of petrochemicals, aromatic and volatile hydrocarbons in returnable PET containers

Output range

Up to 36,000 containers/h

- 1 Machine protection without rejection at the infeed (machine stop with horizontal containers)
- 2 Height detection unit (option)
- 3 Cap detection unit (option)
- 4 Optimised scuffing detection unit (option)
- 5 Rejection at machine infeed (Option)
- 6 Mass spectrometer
- 7 Colour camera
- 8 Rejection of contaminated containers
- 9 Rejection monitor
- 10 Collecting tank

Aircontronic Compact Figures, data, facts

KRONES Aircontronic

Design features

- In-line machine system
- Mounted on single-lane conveyor
- Contamination detection by mass spectrometer
- Non-contact sampling
- Hygienic design

Additional equipment

CCD camera for colour analysis of liquids with no gas phase



Remote maintenance via teleservice



Ergonomic touch-screen operation

Operation and change-over

- Change-over to other container types without the exchange of handling parts
- 15-inch touch-screen
- Display and storage of all relevant operating data
- Graphical malfunction display
- Secure access to the user interface using individual transponders
- Different access levels for individual operators depending on the assigned authorisation
- Monitoring and parameter-setting possible by teleservice on request

Aircontronic Compact

Your benefits

KRONES Aircontronic

■ Compact design

The Aircontronic Compact is true to its name: the in-line machine's compact design means it takes up little space on the bottling line.

■ Hygienic design

Its open design, with sloping surfaces, protects the inspector against dirt deposits and minimises cleaning effort.

■ Low maintenance costs

No handling or moving parts, so no wear.

■ Fast format-changing

The inspector needs no type-dependent handling parts at all, and so can be converted to handle different container sizes in just minutes.

■ Protection against inappropriate access

By means of individual transponders and different access levels, the access rights of each operator can be precisely defined.

■ Unified operator control logic

All KRONES machines are equipped with a uniform operating concept for maximum user-friendliness.

■ Remote diagnostics and maintenance via teleservice

The teleservice provides specialist consultancy and service around the clock. If required, a KRONES technician can access your inspector via a secured data line. In this way, parameter settings, software updates and malfunction analyses can be performed reliably, cost-efficiently and without delay.



*Liquid colour
detection by
camera*

Aircontronic Linear SAM – glass contamination detection “at a sniff”

KRONES Aircontronic

When empty glass containers are returned to the bottling plant, they occasionally contain contaminations which may damage the washer. A single bottle is enough to render the entire caustic unusable and bring about a production stop. As the Aircontronic Linear SAM reliably detects the “culprits”, it protects your washer and keeps production flowing.



Aircontronic Linear SAM

Figures, data, facts

KRONES Aircontronic

Method of operation

The Aircontronic Linear SAM is installed on the single-lane conveyor upstream of the washer. To take samples, it first blows a stream of air into the bottle and then sucks out the displaced gas. It takes less than 100 milliseconds to take a sample from each bottle and analyse it. The stroboscopic analysis module detects petrochemicals by means of pulse-fluorescence. Every bottle detected as contaminated generates a “bad” signal which can be transmitted to a rejection unit.

Application

Detection of petrochemicals in returnable PET containers

Output range

Up to 36,000 containers/h

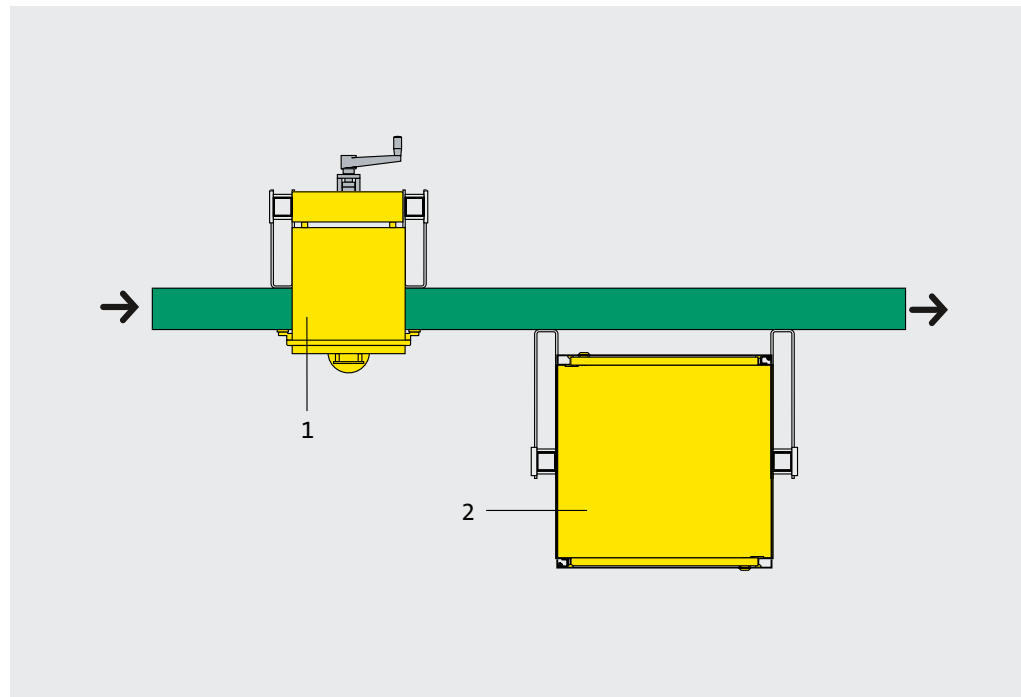

- 1 Analyser
- 2 Analysis unit
(variable setup)

Design features

- In-line machine system
- Mounted on single-lane conveyor
- Contamination detection by pulse-fluorescence
- Non-contact sampling
- Height-adjustable analyser

Operation

- Operator control via membrane keypad
- Monitor with display of counter readings and all relevant operating data
- Different access levels for individual operators depending on the assigned authorisation

Aircontronic Linear SAM

Your benefits

KRONES Aircontronic

- **Cost-efficient system**
No handling or moving parts, so no wear.
- **Safety for your production**
The Aircontronic Linear SAM protects your washer against hazardous contamination and so prevents machine downtimes.
- **High-speed monitor**
The high-performance detection method checks every bottle in less than 100 milliseconds.



Suction inlet on analyser

Aircontronic AquaLinear – the inspector for large-area monitoring

KRONES Aircontronic

The Aircontronic AquaLinear specialises in large-volume PET containers such as are used in conjunction with water dispensers. Using two different detection methods, it detects both aromatic and volatile hydrocarbons and petrochemicals. As a result, health risks and impairments of taste are safely eliminated.



Aircontronic AquaLinear Figures, data, facts

KRONES Aircontronic

Method of operation

The Aircontronic AquaLinear is installed on the conveyor upstream of the washer. To take samples, it first blows a stream of air into the bottle and then sucks out the displaced gas. It takes less than 100 milliseconds to take a sample from each bottle and analyse it. The stroboscopic analysis module – “SAM” for short – detects petrochemicals by pulse-fluorescence while the water analysis module (WAM) identifies aromatic substances. Every bottle detected as contaminated generates an interference signal which can be transmitted to a rejection unit.

Application

Detection of petrochemicals and aromatic substances in large-volume returnable PET containers

Output range

Up to 28,000 containers or 4,000 gallon-bottles per hour

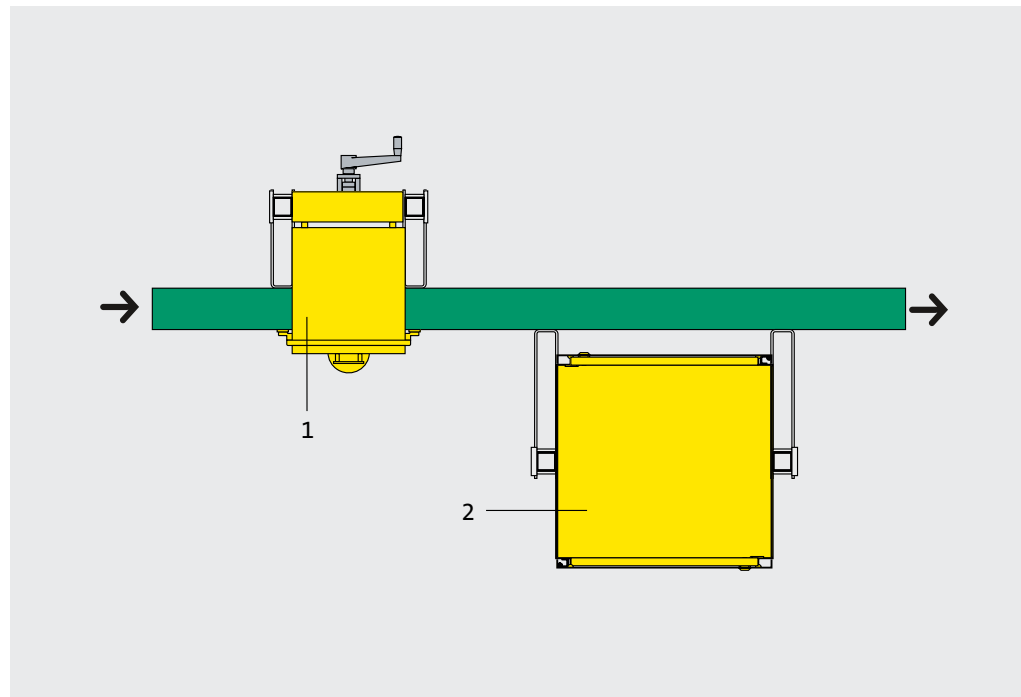

- 1 Analyser
- 2 Analysis unit
(variable setup)

Design features

- In-line machine system
- Mounted on single-lane conveyor
- Contamination detection through pulse-fluorescence and photo-ionisation
- Non-contact sampling
- Height-adjustable analyser

Operation

- Operator control via membrane keypad
- Monitor with display of counter readings and all relevant operating data
- Different access levels for individual operators depending on the assigned authorisation

Aircontronic AquaLinear

Your benefits

KRONES Aircontronic

- **Cost-efficient system**
No handling or moving parts, so no wear.
- **Safety for your production**
The Aircontronic AquaLinear protects your washer against hazardous contamination and so prevents machine downtimes.
- **High-speed monitor**
The high-performance detection method checks every bottle in less than 100 milliseconds.



Measuring station