

Formapak with Bartelt Model B Filler

SPECIFICATIONS

Packet size: Minimum of 1½" wide x 2" long
Maximum of 6" wide x 5" long

Optional Equipment:

1. Vertical perforating mechanism
2. Printing equipment
3. Electronic eye registration
4. Interchangeable sealing dies
5. Wide choice of filling equipment

FORMAPAK for Powders

Formapaks form, fill and seal flexible packets automatically. They handle most supported thermo-sealing web materials, registered and non-registered.

FEATURES

- Formapak is extremely simple and compact — floor space is only 3 feet square.
- Single station operation permits high production speed.
- Temperature and pressure of the sealing rolls are adjustable.
- Formapak functions excellently with a wide variety filling equipment.

APPLICATION

Formapak efficiently handles powders and granular products.

SPEED

Formapak can be rated from 40 to 100 cycles per minute. Packet production speed depends on cycle rate, number of packets per cycle, packet size, product characteristics, and fill quantity.

BARTELT FORMAPAK for POWDERS

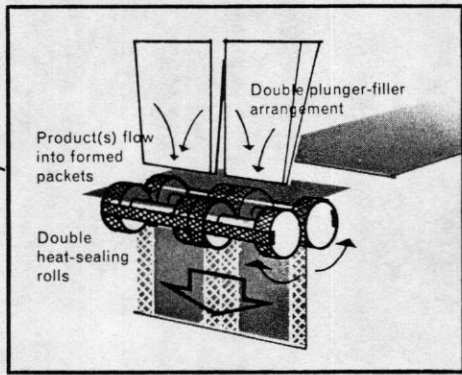
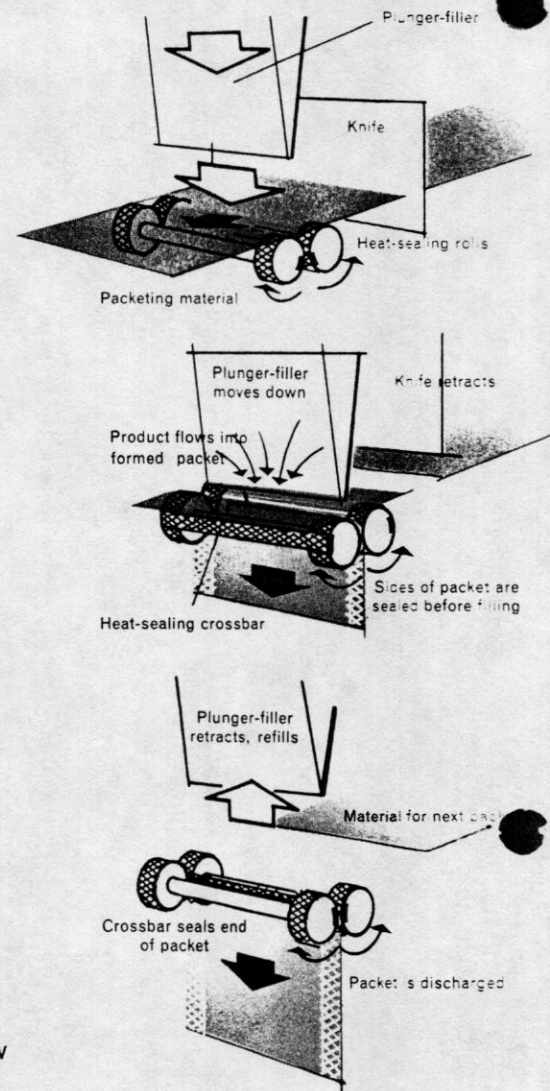
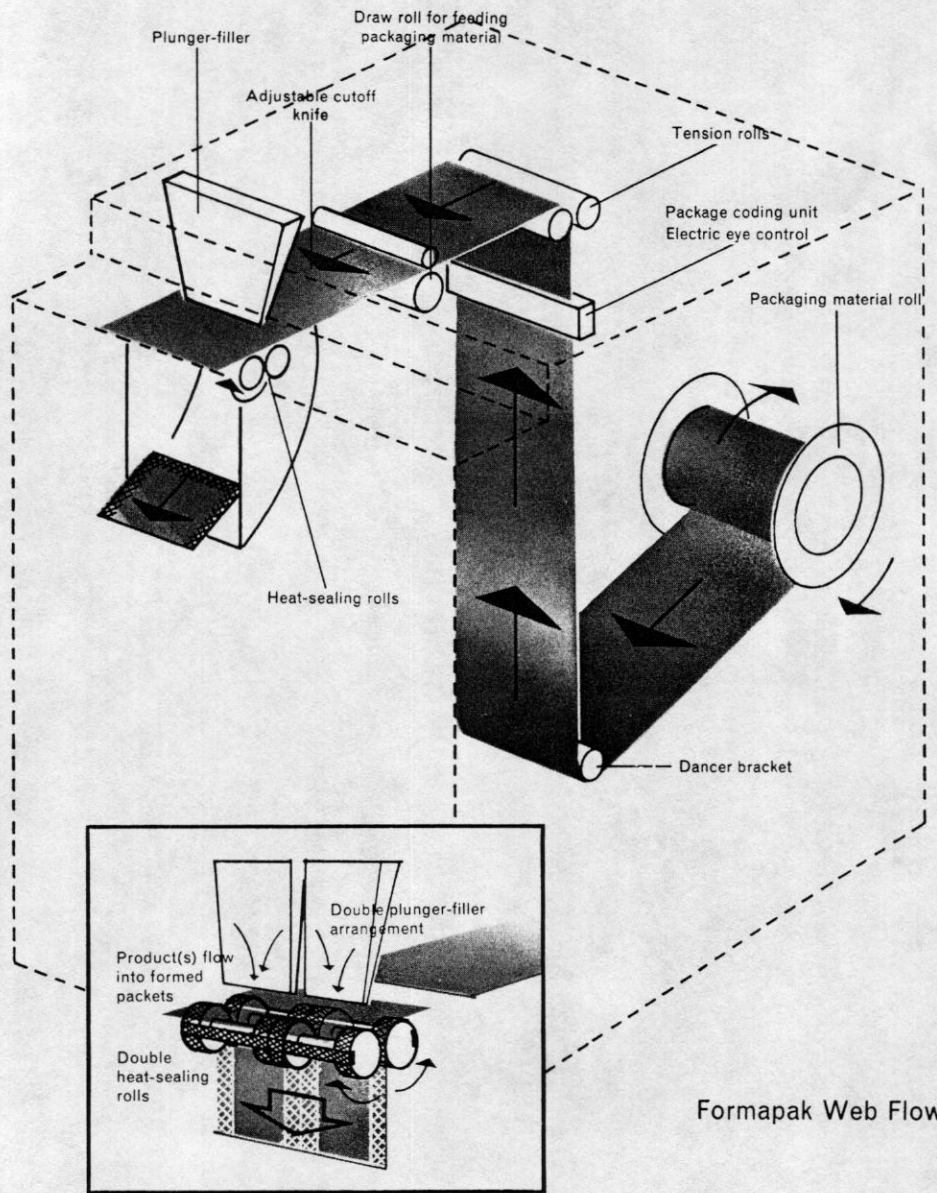

Formapak Web Flow

SPECIFICATIONS

Power: 220 (or 440) volt, 60 cycle, 3-phase.

Control: 110 volt, 60 cycle, single phase.

Drive Motor: ½ hp totally enclosed industrial motor, mounted on an adjustable base with variable pitch pulley.

Compressed Air: 100 psi and 3 cfm.

Materials and Finish: Base — industrial weldment; Castings — aluminum and special alloys as required. Machine is filled, primed and painted with highest quality refrigerator-white baked enamel as standard finish.

Dimensions: Front to back is 3 feet; length is 3 feet; and height is from 4 to 8 feet.

Weight (crated): Approximately 2000 pounds.

"A Bartelt machine, engineered specifically for your packaging program is your best packaging investment."

**Packaging - Processing
Bid on Equipment**

1-847-683-7720

www.bid-on-equipment.com

BARTELT ENGINEERING CO., INC.

SUBSIDIARY
1900 HARRIS