



**FEATURES**

- Formapak is extremely simple and compact — floor space is only 3 feet square.
- Single station operation permits high production speed.
- Temperature and pressure of the sealing rolls are adjustable.
- Formapak functions excellently with a wide variety filling equipment.

**APPLICATION**

Formapak efficiently handles piece parts, hardware, small assemblies, and any small hard-outline object.

**SPEED**

Formapak can be rated from 40 to 100 cycles per minute. Packet production speed depends on cycle rate, number of packets per cycle, packet size, product characteristics, and fill quantity.

**SPECIFICATIONS**

**Packet size:** Minimum of 1½" wide x 2" long  
Maximum of 6" wide x 5" long

**Optional Equipment:**

1. Vertical perforating mechanism
2. Printing equipment
3. Electronic eye registration
4. Interchangeable sealing dies
5. Wide choice of filling equipment

**FORMAPAK  
for Hardware**

Formapaks form, fill and seal flexible packets automatically. They handle most supported thermo-sealing web materials, registered and non-registered.

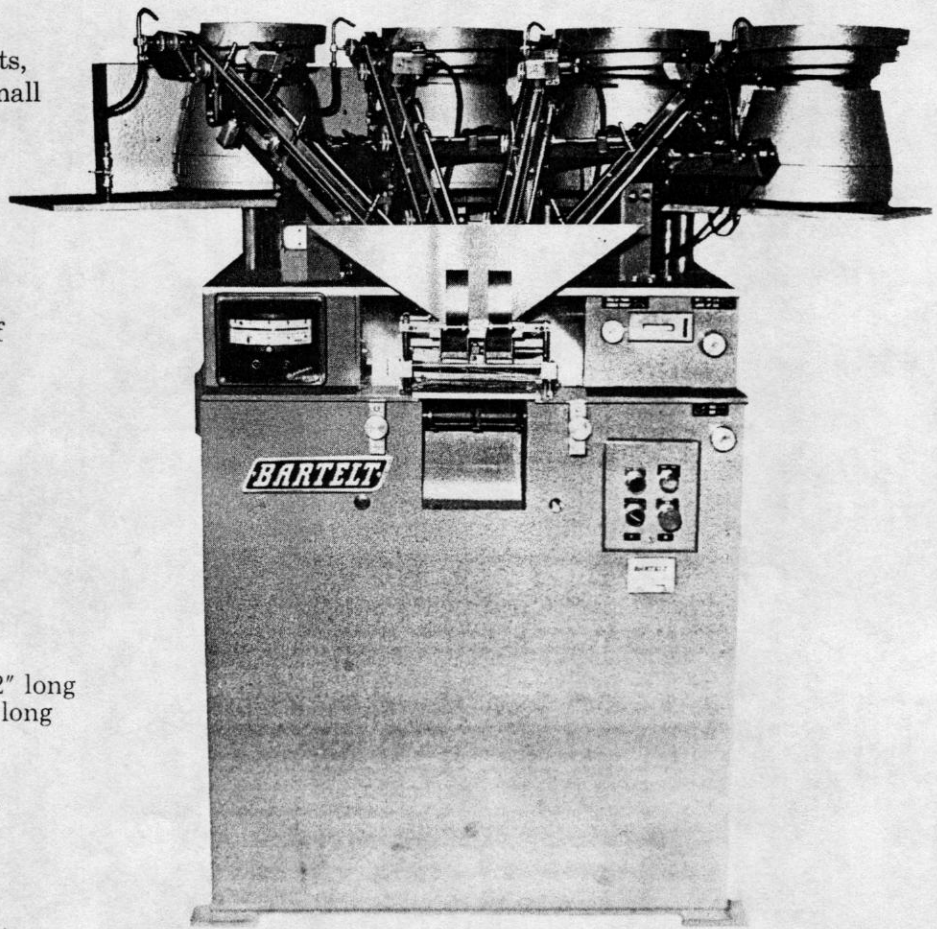

Formapak with Four V-bracketed Feeders

**Packaging - Processing  
Bid on Equipment**

1-847-683-7720  
www.bid-on-equipment.com

# BARTELT FORMAPAK for HARDWARE

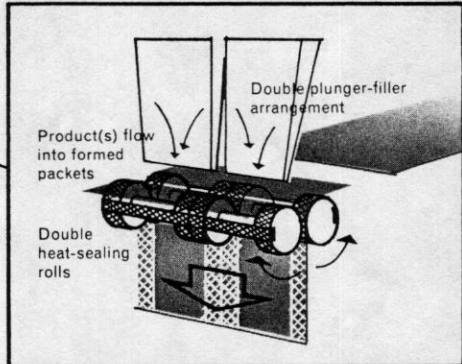
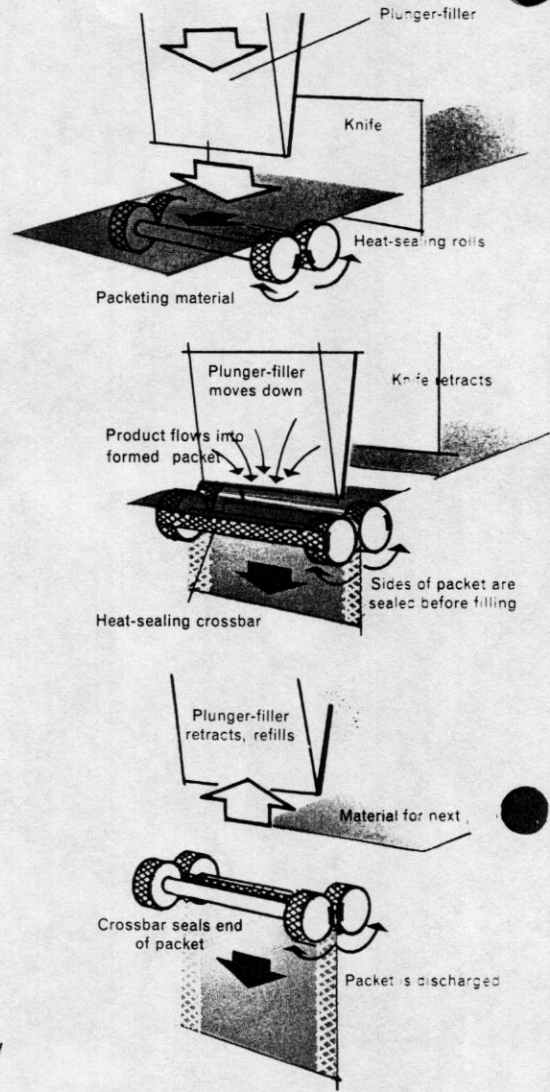
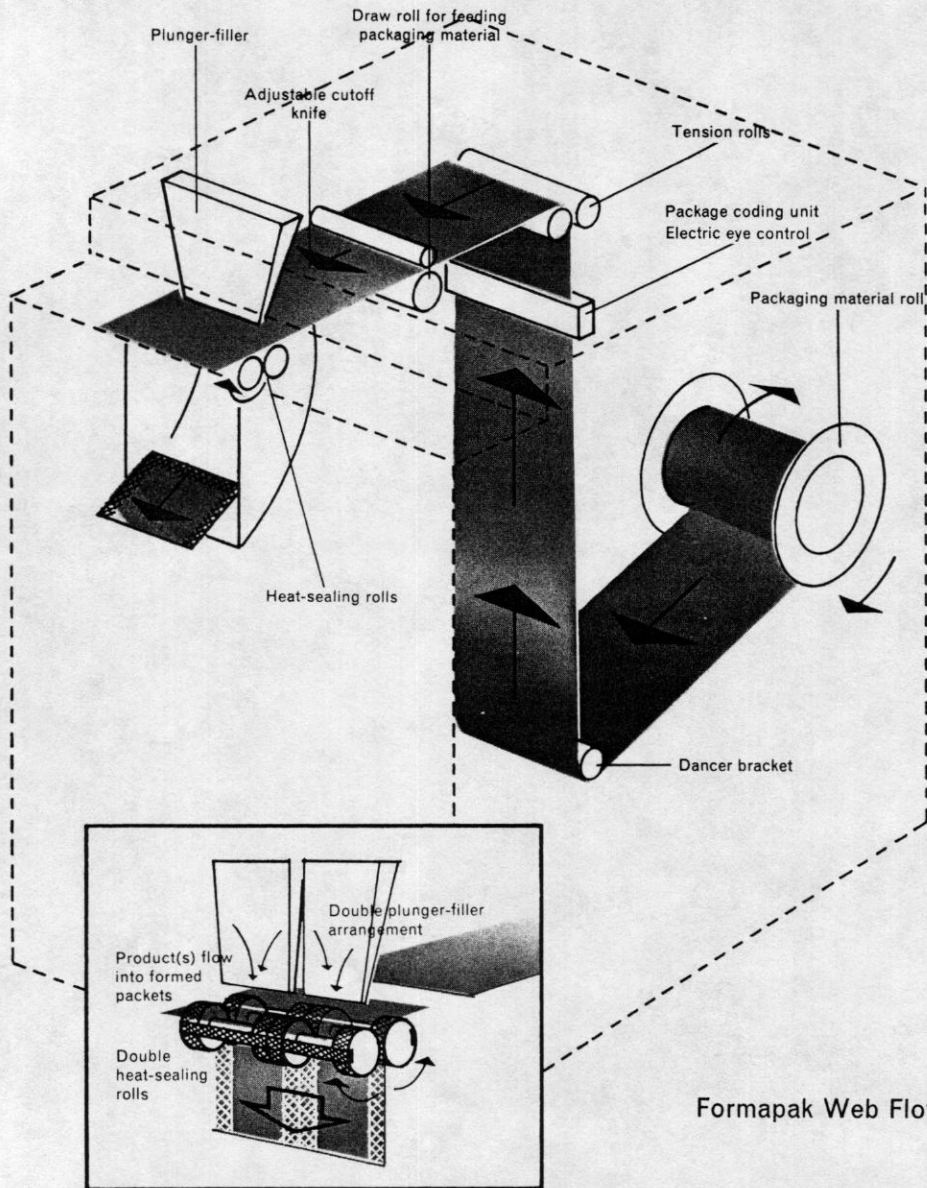

Formapak Web Flow

## SPECIFICATIONS

**Power:** 220 (or 440) volt, 60 cycle, 3-phase.

**Control:** 110 volt, 60 cycle, single phase.

**Drive Motor:** ½ hp totally enclosed industrial motor, mounted on an adjustable base with variable pitch pulley.

**Compressed Air:** 100 psi and 3 cfm.

**Materials and Finish:** Base — industrial weldment; Castings — aluminum and special alloys as required. Machine is filled, primed and painted with highest quality refrigerator-white baked enamel as standard finish.

**Dimensions:** Front to back is 3 feet; length is 3 feet; and height is from 4 to 6 feet.

**Weight (crated):** Approximately 2000 pounds.

"A Bartelt machine, engineered specifically for your packaging program is your best packaging investment."

**Packaging - Processing  
Bid on Equipment**

1-847-683-7720

[www.bid-on-equipment.com](http://www.bid-on-equipment.com)

**BARTELT ENGINEERING CO., INC.**

SUBSIDIARY  
1900 HARRI