

POUCH KING®

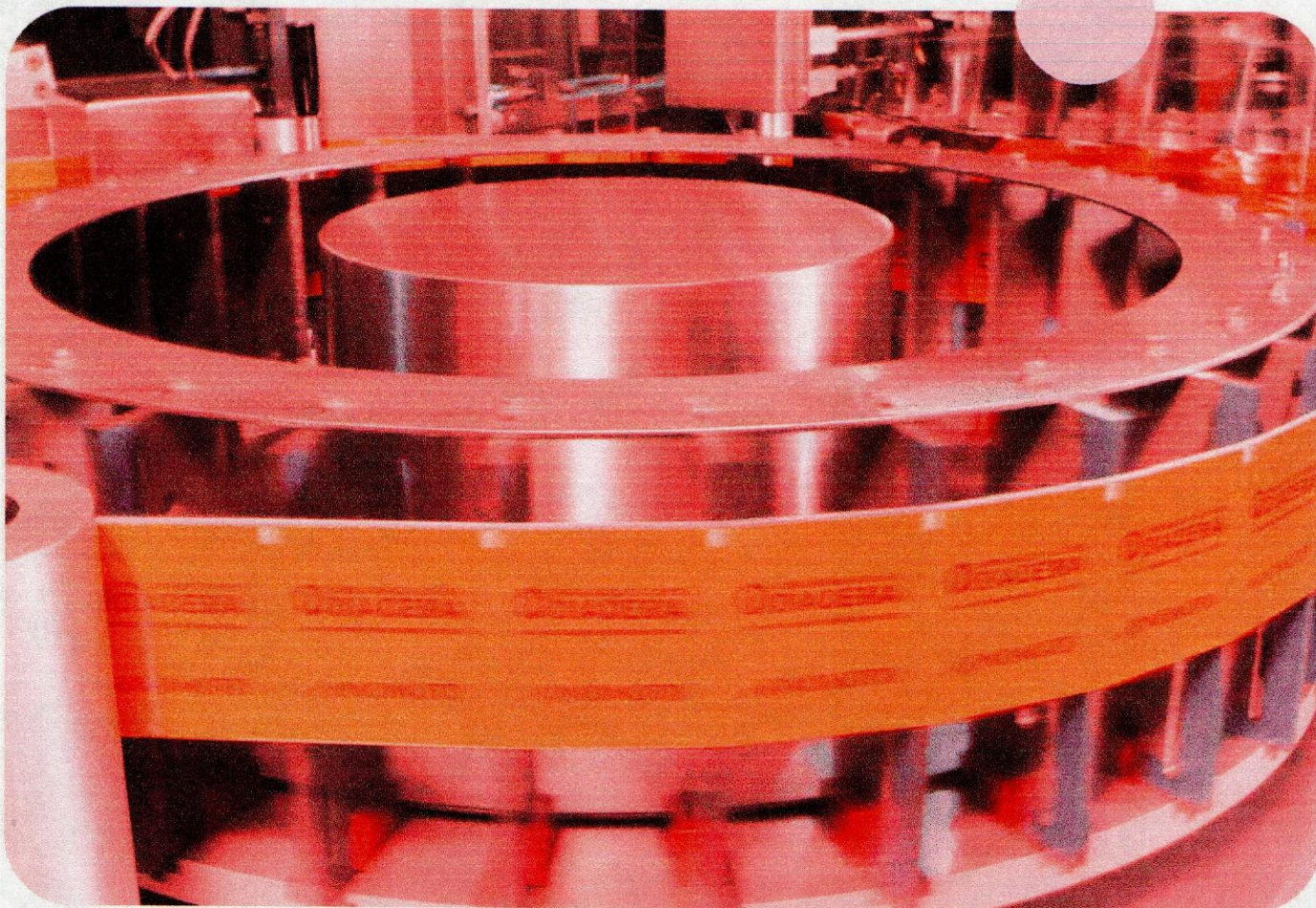

Packaging – Processing

Bid on Equipment

1-847-683-7720

www.bid-on-equipment.com

POUCH KING®

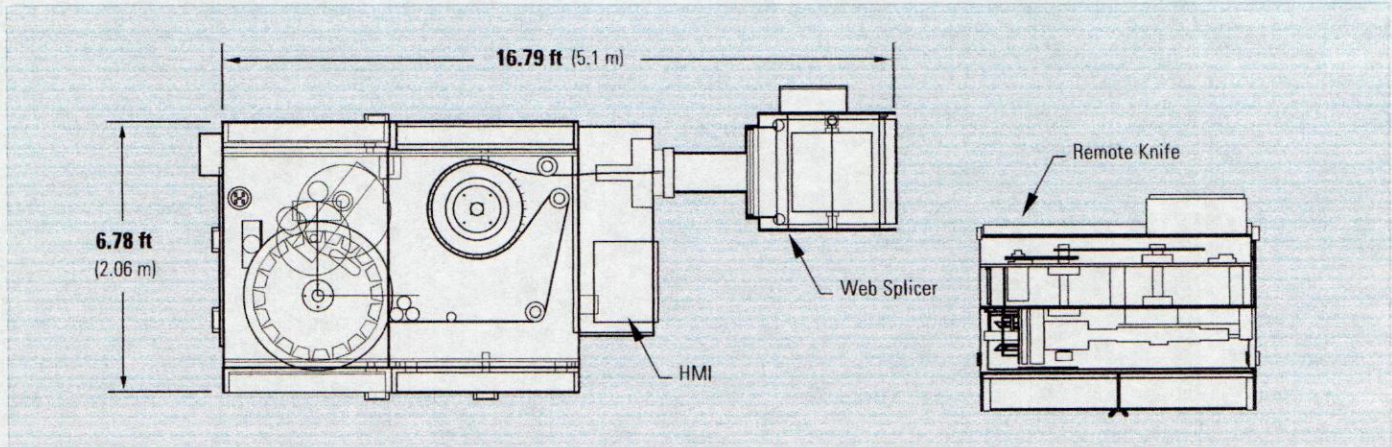

The Jones Pouch King® first introduced high reliability at high speeds to the industry over thirty years ago. Now, the new modular Pouch King® is more reliable and user-friendly than ever.

Product Features and Options

- High speed, high reliability @ 24/7 operation
- Sealing speeds over 4,000 linear inches per minute
- Patented vertical sealer technology
- Reduced footprint and web path
- Fully servo-driven machine
- Modular design
- Stainless steel frame construction
- Touch-screen HMI
- Multiple component filling (online blending)
- Complete collating, transfer & cartoning systems
- Direct deposit knife
- Tote loading/unloading
- Allergen filling
- Automatic web splicer
- Pouch printing and coding
- Easy open tear notch
- Pouch conditioning
- Washdown filling module

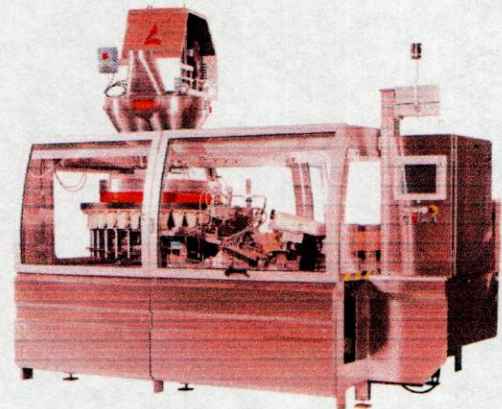

Pouch Styles

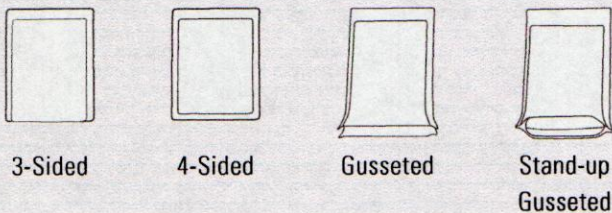

Technical Details

Linear Speed	over 4,000 linear inches per minute
Pouch Width	2" (51 mm) to 8" (203 mm)
Pouch Height	2" (51 mm) to 7.5" (190 mm)
Optional Height Range	up to 10" (254 mm)

