

Goulds Models 3900 API-610 In-Line Process Pumps

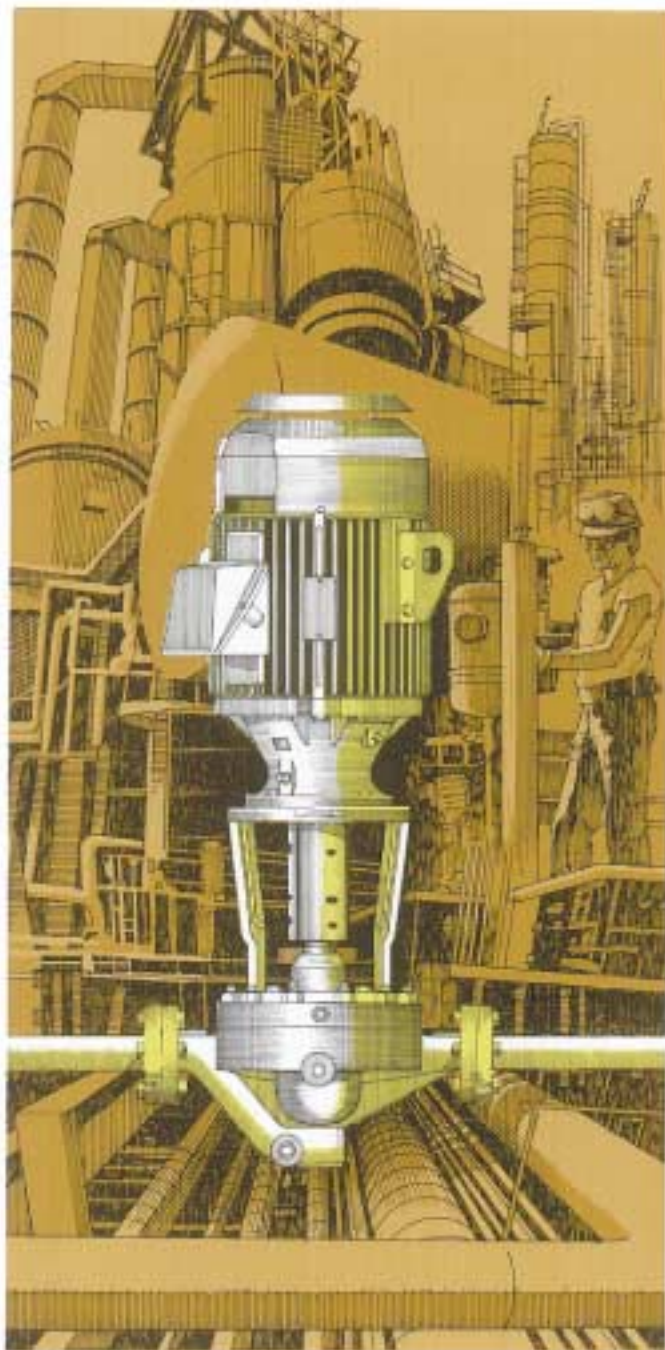

Goulds Pumps



ITT Industries
Engineered for life

Packaging - Processing

Bid on Equipment

1-847-683-7720

www.bid-on-equipment.com



Goulds Model 3900 is a vertical in-line, single stage, API-610 process pump. In-line mounting close to supply source simplifies plant design and minimizes installation cost; saves space.

Model 3901 is a close-coupled version of the 3900 and is normally furnished with a single inside mechanical seal.

Goulds Model 3900

In-Line Process Pumps Designed to Meet Requirements of API-610

- Capacities to 7500 GPM (1700 m³/h)
- Heads to 750 feet (229 m)
- Temperatures to 650° F (343° C)
- Pressures from full vacuum to 595 PSIG (4100 kPa)

Design Features

In-Line Installation Mounts in, and supported by, the piping system. Eliminates concrete foundation and grouting costs.

Dual Volute 3 inch discharge and larger.

Removable Seal Chamber Allows easy removal and replacement of mechanical seal. One craft maintenance.

Renewable Throat Bushing Maintains minimum shaft deflection for longer seal life. Renewal easily accomplished on-site.

API-610 Bearing Life Balance holes and size, location and diameter of wearing rings assure hydraulic balance to meet API-610 bearing life requirements.

Renewable Impeller and Case Wear Rings and Stuffing Box Bushing API-610 clearances are standard.

Impeller Multiple closed impellers for each casing size to assure maximum efficiency, minimum NPSHR.

Stuffing Box Removable seal housing design allows use of packing; single or tandem mechanical seals.

Rigid Coupling Designed to couple and align pump and driver shaft. Maintains minimum shaft runout for long seal life.

Services

Petrochemical
Chemical
Refining
Offsite
Gasoline Plants
Natural Gas Processing
General Services

Packaging - Processing

Bid on Equipment

1-847-683-7720

www.bid-on-equipment.com



Model 3900 API-610 In-Line Process Pumps

Heavy Duty Design Features for Wide Range of Services

Packaging - Processing
Bid on Equipment
1-847-683-7720
www.bid-on-equipment.com

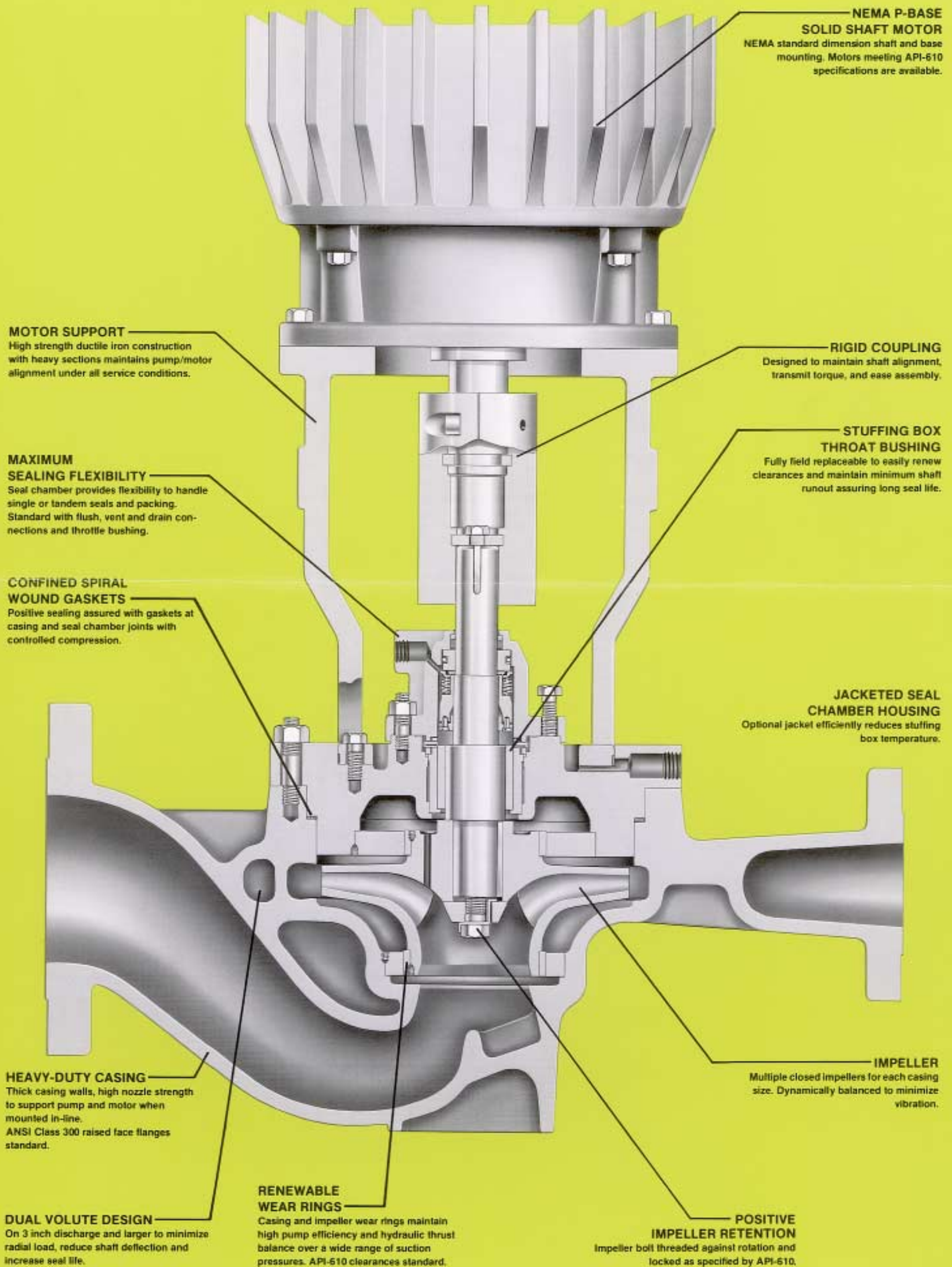

Special Features for Ease of Maintenance

Stuffing Box Throat Bushing Removal*

Goulds Model 3900 features a unique seal chamber which facilitates easy on-site removal of the seal bushing and bushing holder during mechanical seal replacement. The stuffing box throat bushing assures long mechanical seal life.



Rotating Element Lifting Device*

Large pump sizes are standard with a unique device built in the rigid coupling that allows easy lifting of the rotating element during maintenance.



Model 3901 Close-Coupled Design

A close-coupled version of the 3900 in-line pump allows users a low cost alternative to the rigid spacer coupling design. Standard construction includes a single inside mechanical seal and a stub shaft pinned to the NEMA P-base motor shaft extension. The Model 3901 can also be furnished with the impeller attached directly to a non-NEMA motor shaft extension.

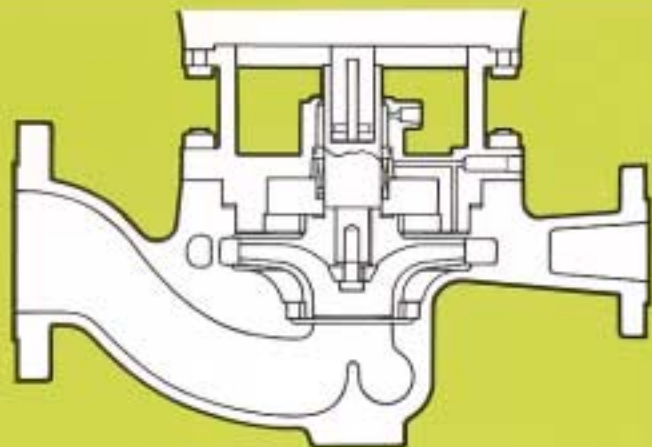

Packaging - Processing

Bid on Equipment

1-847-683-7720

www.bid-on-equipment.com

50 Hz Performance Curves

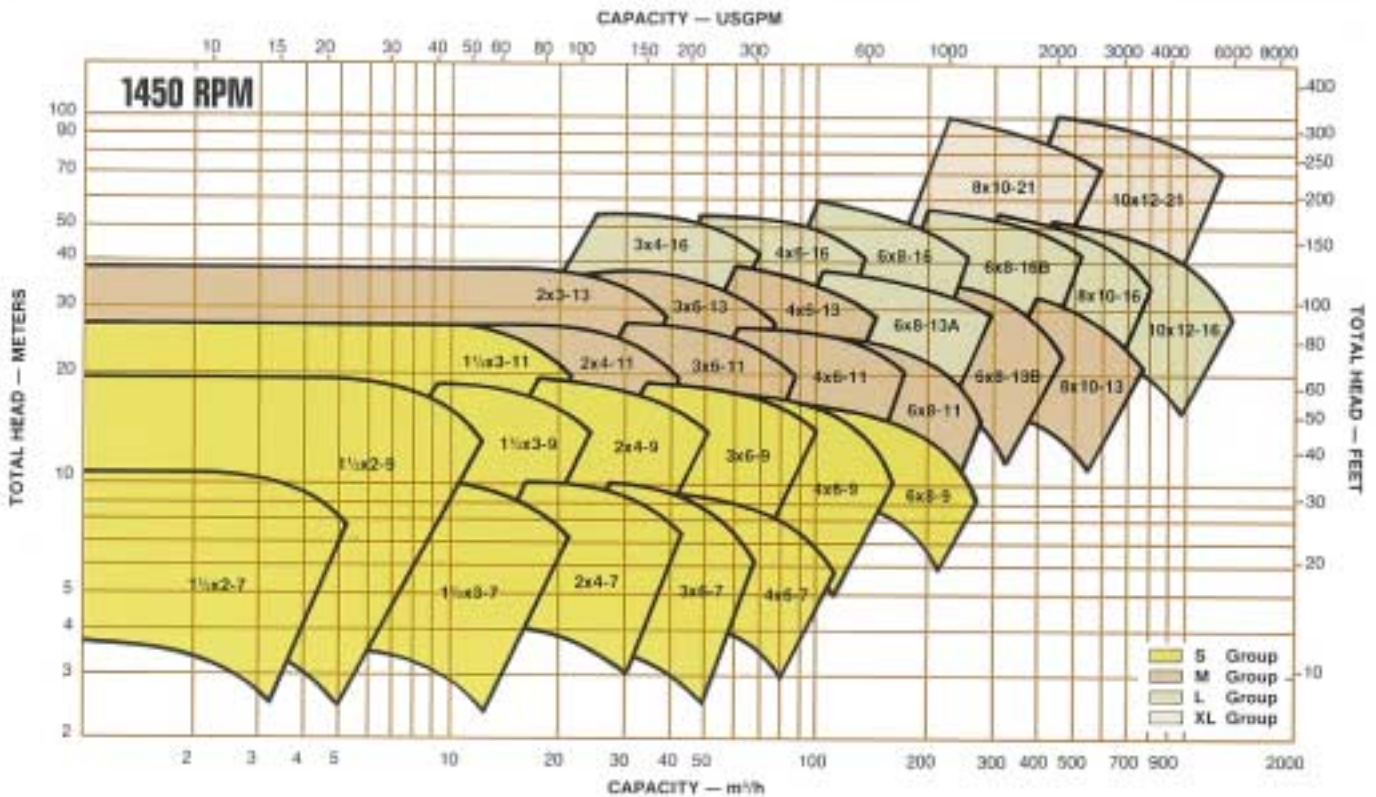
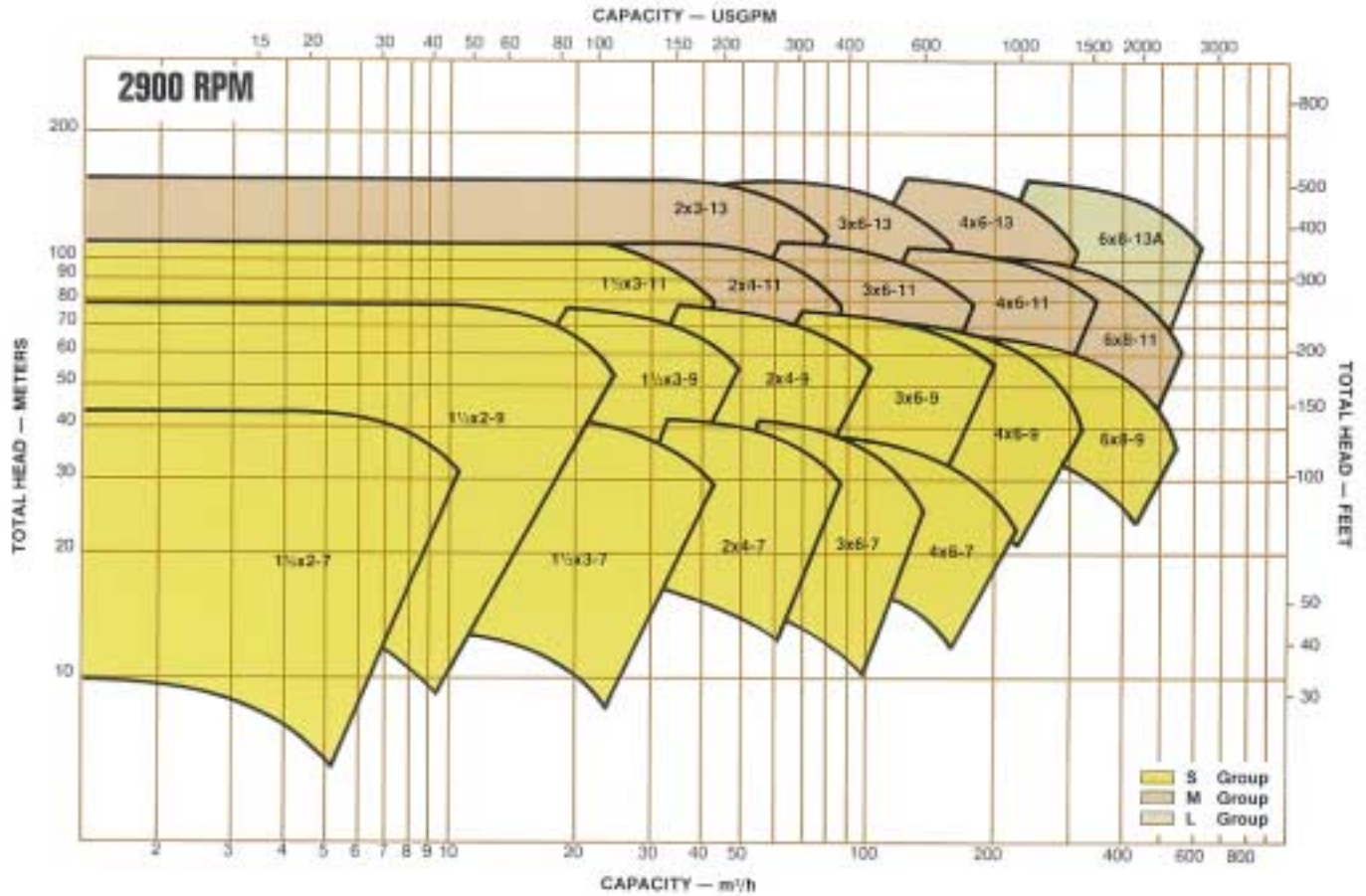

60 Hz Performance Curves

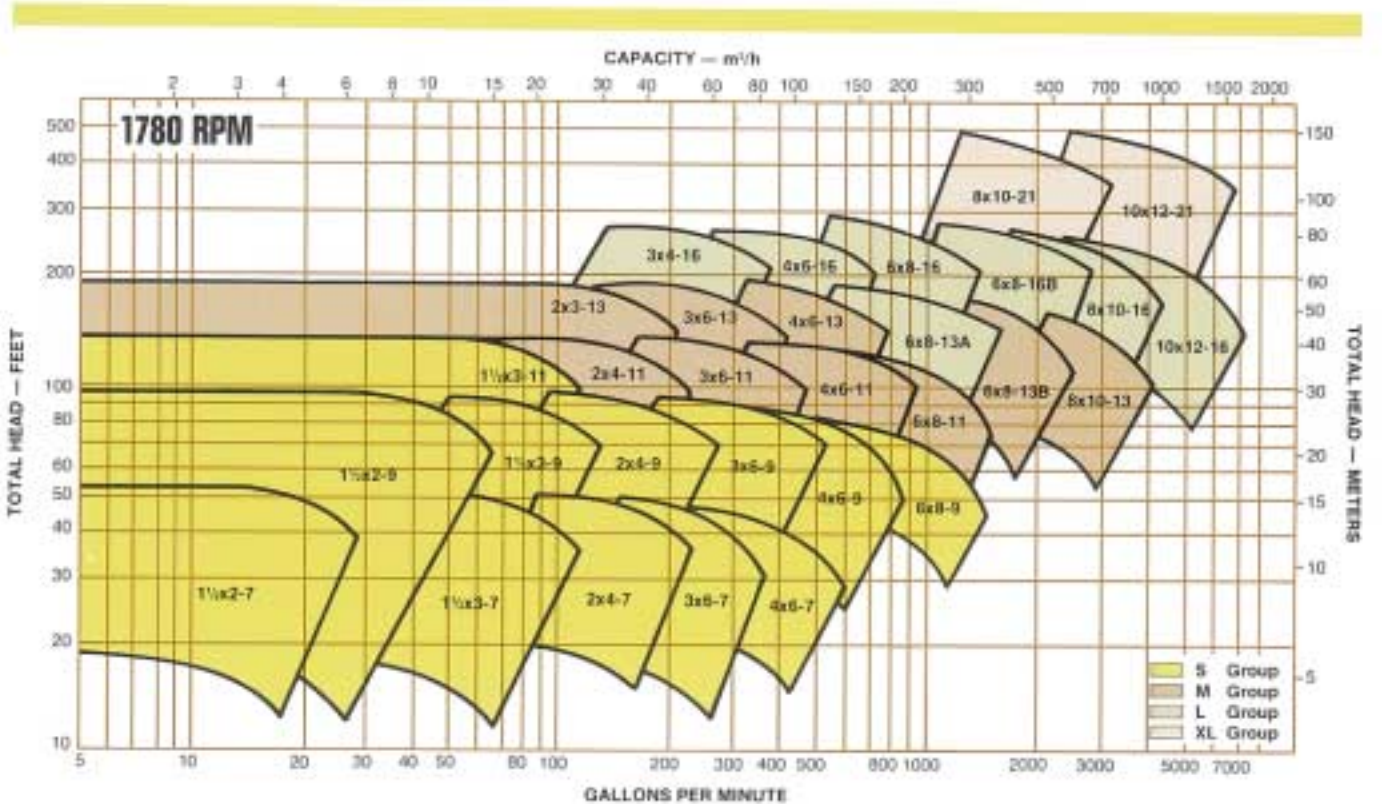
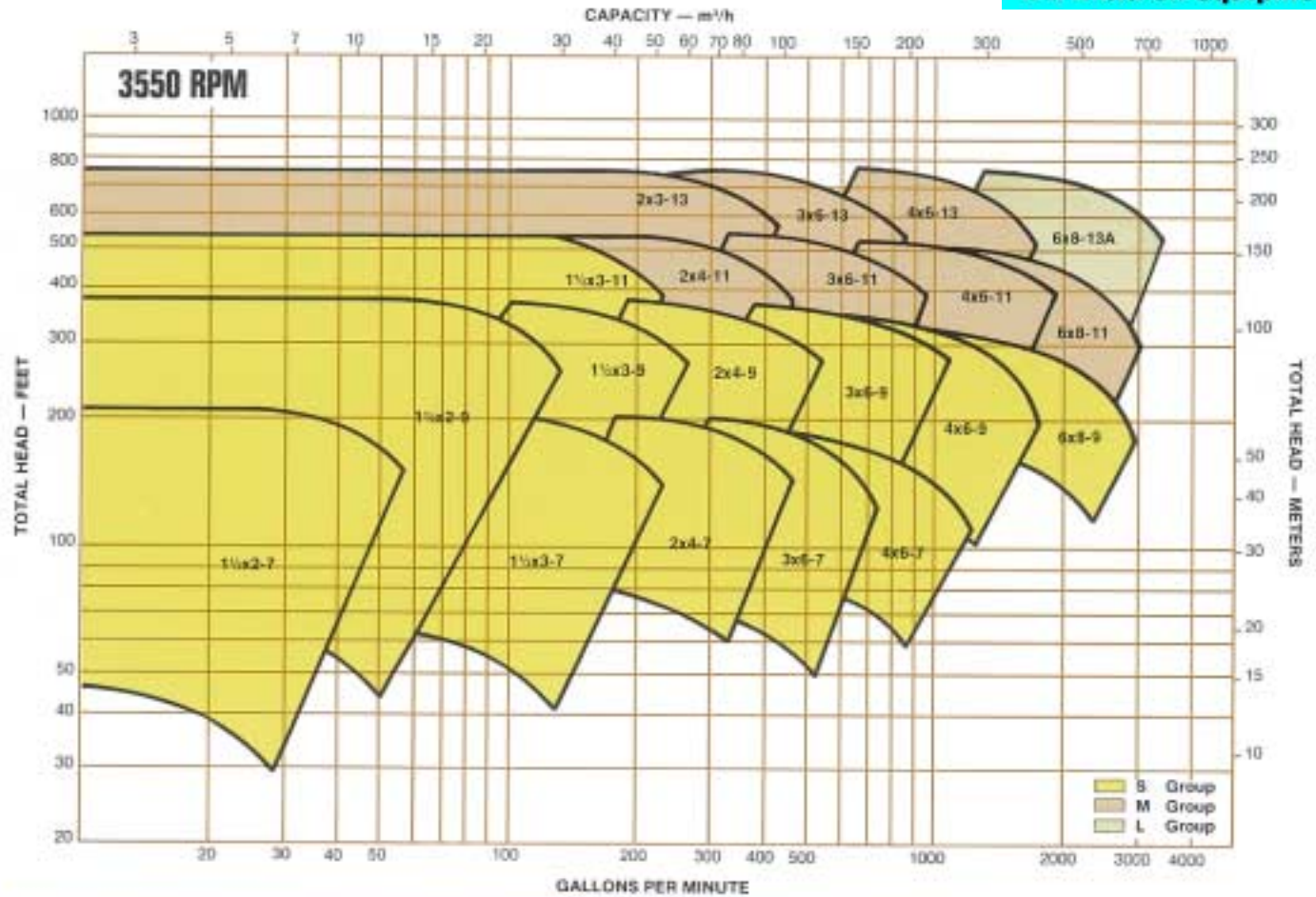

Modular Interchangeability

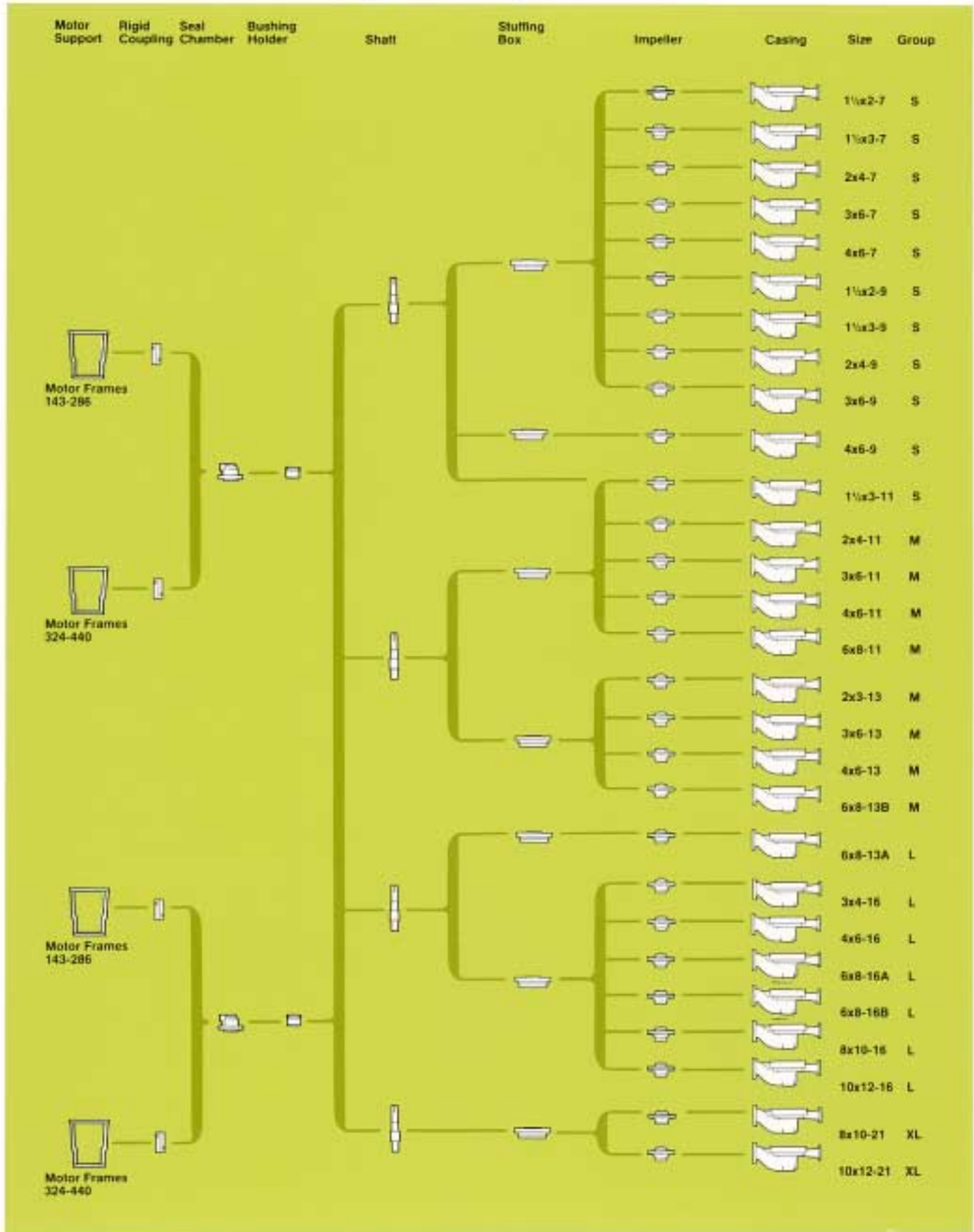

Maximum Sealing Flexibility

Special Chamber Facilitates Seal Replacement

Goolds Model 3900 features a seal chamber which functions as a conventional stuffing box and gland providing full accessibility to the mechanical seal for easy replacement. The special chamber design also allows use of standard seals with set screws to position and drive the rotary unit providing ease of maintenance.

The seal chamber is standard with permanently identified flush, vent and drain connections. On high temperature services the chamber can be easily replaced with an optional cooled design without disassembling the entire pump. This can be easily accomplished during routine mechanical seal maintenance.



Removal of seal chamber provides full accessibility to mechanical seal.

Model 3900 is designed to meet a wide range of sealing requirements of the petroleum and chemical industries.

Flush, vent and drain connections standard.

Stuffing Box Cooled or non-cooled.

Seal Types Single, balanced or tandem.

Seal Mounting Flexible O-ring mounted.

Single Inside Balanced Seal

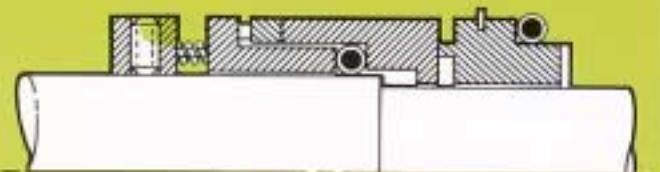

Single Inside Metal Bellows Seal



Tandem Seal



Stationary Metal Bellows Seal

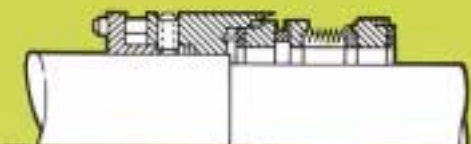

Packed Stuffing Box



Parts List and Materials of Construction

Item No.	No. Req'd Per Pump	Part Name	Materials									
			(2)API Desig. Case/Trim	S1 Steel/C.I.	S4 Steel/Stl. Imp.	S5 Steel/Chr. W.P.	S6 Steel/Chrome	S9 Steel/Monel	C6 12% Chrome	A7 304SS	A8 316SS	GA-20
100	1	Casing				Carbon Steel			12% Chrome	18-8SS	316SS	GA-20
101	1	Impeller	C.I.		Carbon Steel	12% Chrome	Monel	12% Chrome	18-8SS	316SS	GA-20	
105	1	Lantern Ring (not shown)			C.I.		Monel		316SS		—	
106	1 set	Packing Stuffing Box (not shown)				High Temperature						—
122	1	Shaft			AISI 4140		K Monel	12% Chrome		316SS	GA-20	
150	1	Seal Chamber			Carbon Steel					316SS	GA-20	
164	1	Casing Wear Ring	C.I.			12% Chrome (Hard)	Monel	12% Chrome (Hard)		Hard Faced 316SS	GA-20	
197A	1	Stuffing Box Throat Bushing					Carbon				—	
198	1	Impeller Screw			AISI 4140		Monel		316SS		GA-20	
199	1	Impeller Washer			Steel		Monel		316SS		GA-20	
199A	1	Impeller Lockwasher					316SS				—	
202	1	Impeller Wearing Ring (Casing Side)	C.I.			12% Chrome (Hard)	Monel	12% Chrome (Hard)		Hard Faced 316SS	GA-20	
203	1	Impeller Wearing Ring (S.B. Cover Side)	C.I.			12% Chrome (Hard)	Monel	12% Chrome (Hard)		Hard Faced 316SS	GA-20	
210	1	Gland Packing (not shown)					Non-Asbestos					
230	1	Backplate Wearing Ring	C.I.			12% Chrome (Hard)	Monel	12% Chrome (Hard)		Hard Faced 316SS	GA-20	
232	1	Rigid Coupling Assembly					Carbon Steel					
240	1	Motor Support					Ductile Iron					
351 ¹	1	Gasket (Case to Backplate)				316SS/Non-Asbestos	Monel/Teflon		316SS/Non-Asbestos		GA-20/Teflon	
353	4	Gland Stud — Packed Box Seal Chamber			AISI 4140		K Monel		18-8SS	316SS		
355	4	Gland Stud Nut — Packed Box Seal Chamber			AISI 4140		K Monel		18-8SS	316SS		
356A ²		Stud — S.B. to Casing			AISI 4140		K Monel		AISI 4140			
358	1	Plug — Casing Drain (not shown)			Carbon Steel			12% Chrome	18-8SS	316SS	GA-20	
358D	1	Plug — Casing Vent (not shown)			Carbon Steel			12% Chrome	18-8SS	316SS	GA-20	
360D ³	1	Gasket — Seal Chamber			Spiral Wound		O-Ring	Spiral Wound		O-Ring		
370H	4	Hex Cap Screw — Frame to Backplate			AISI 4140		K Monel		AISI 4140			
418	3	Hex Cap Screw, Jacking — Seal Chamber					Carbon Steel					
418A	3	Hex Cap Screw, Backplate Jacking (not shown)					Carbon Steel					
425 ⁴		Hex Nut — Casing Stud			AISI 4140		K Monel		AISI 4140			
444	1	Backplate			Carbon Steel			12% Chrome	18-8SS	316SS	GA-20	
445A	2	Pin (Bushing Holder)					316SS				—	
467	1	Bushing Holder			Carbon Steel			12% Chrome	18-8SS	316SS	GA-20	

NOTES:

- ¹ Gland gaskets may be spiral wound 316SS or O-rings of material suitable for the application.
- ² Materials listed are equal to the respective API-610 6th Edition material classes. In some cases superior materials are substituted.
- ³ Casing Studs: 7" and 9" — Qty. 12. 11" and 13" — Qty. 16. 16" — Qty. 20. 21" — Qty. 24.
- ⁴ All cast 316SS parts are low carbon 316L CF3M.
- ⁵ Spiral wound with metallurgy and filler as indicated.

Materials of Construction

Material	Casting	Wrought Mat'l
Carbon Steel	ASTM-A216WCB	—
12% Chrome	ASTM A487 Gr. CA6NM	ASTM A276 Type 410
316SS	ASTM A351 Gr. CF3M (4)	ASTM A276 Type 316
Cast Iron	ASTM A48	—
ANSI 4140	—	ASTM A434 Gr. 4140
Ductile Iron	ASTM A536	—

Packaging - Processing

Bid on Equipment

1-847-683-7720

www.bid-on-equipment.com

Sectional View Model 3900

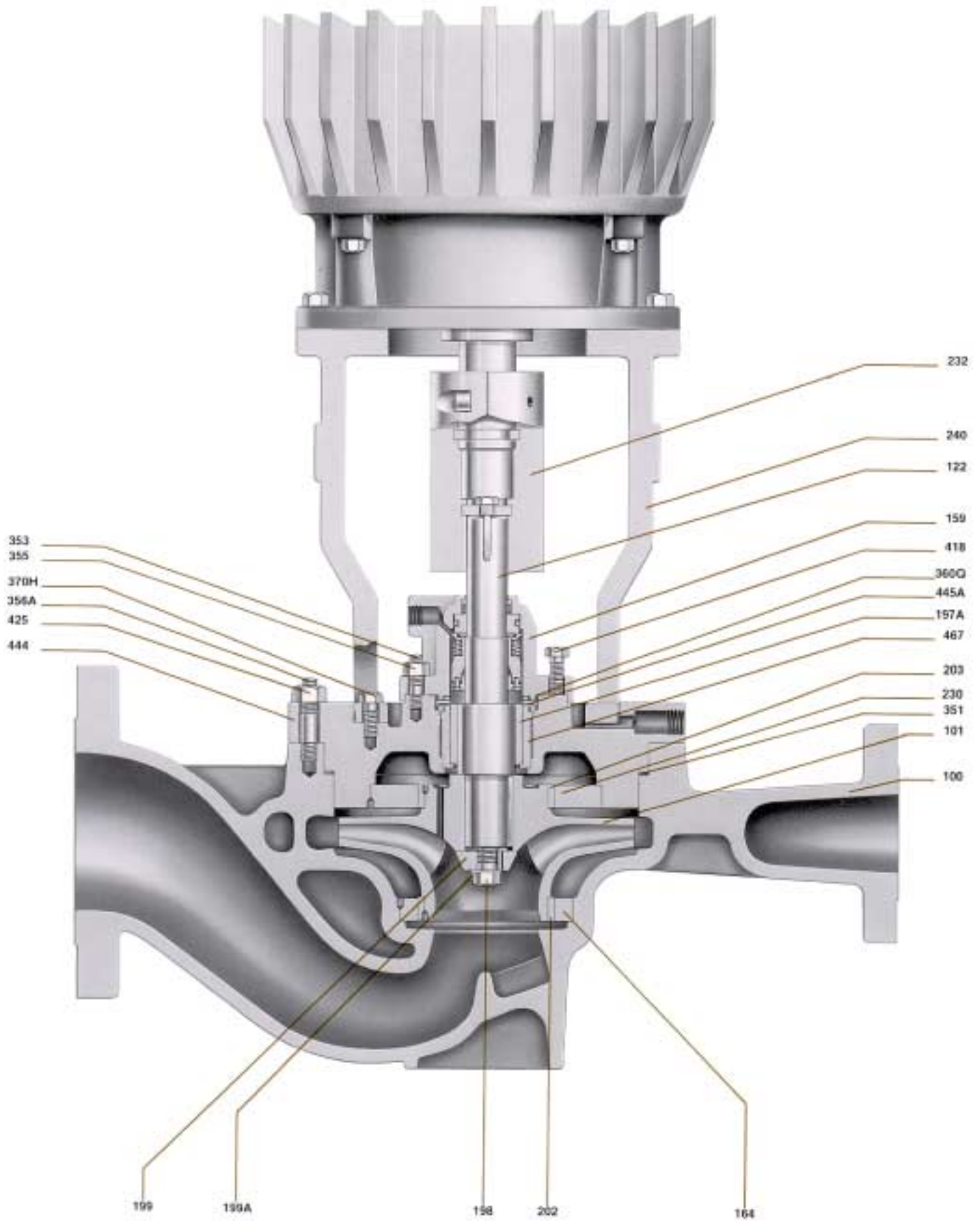

Construction Details

All dimensions in inches and (mm). Not to be used for construction.

		Frame S	Frame M	Frame L	Frame XL
Shaft	Shaft Diameter at Impeller — in. (mm)	1-1/4 (32)	1-5/8 (41)	2-1/8 (54)	2-5/8 (67)
	Shaft Diameter at Coupling — in. (mm)	1-1/2 (38)	1-1/2 (38)	2-1/8 (54)	2-1/8 (54)
	Shaft Diameter under Bushing — in. (mm)	2-3/16 (56)	2-3/16 (56)	2-7/8 (73)	2-7/8 (73)
	Shaft Diameter under Seal — in. (mm)	1-3/4 (44)	1-3/4 (44)	2-3/8 (60)	2-3/8 (60)
	Maximum H.P. per 100 RPM	4.23	9.58	21.07	36.52
Seal Chamber	Size of Packing — in. (mm)	1/2 Sq. (13)	1/2 Sq. (13)	1/2 Sq. (13)	1/2 Sq. (13)
	Number of Rings w/Lantern Ring	6	6	6	6
	Number of Rings w/Lantern Ring	7	7	7	7
	Width of Lantern Ring — in. (mm)	3/4 (19)	3/4 (19)	3/4 (19)	3/4 (19)
	Bore — in. (mm)	2-3/4 (57)	2-3/4 (57)	3-3/8 (73)	3-3/8 (73)
	Depth — in. (mm)	3-7/8 (98)	3-7/8 (98)	3-7/8 (98)	3-7/8 (98)
Pressure Limits	Maximum Suction and/or Working Pressure	See Supplemental Engineering Data — as high as 595 PSIG (4100 KPa)			
	Maximum Test Pressure	One and a half maximum working pressure			
	Corrosion Allowance — in. (mm)	1/8 (3)			
Temp. Limits	Maximum Liquid Temperature — w/o Cooling	350°F (177°C)			
	Maximum Liquid Temperature with Stuffing Box Cooling	650°F (344°C)			

Motor Data

All dimensions in inches and (mm). Not to be used for construction.

		MOTOR FRAMES																					
RPM		143	145	182	184	213	215	254	256	284	286	324	326	364	365	404	405	444	445	447			
Horsepower	3600	Open-Drip	1-1.5	2-3	5	7.5	10	15	20	25	30	40	50	60	75	100	125	150	200	—	—		
		TEFC Expl. Proof	1.5	2	3	5	7.5	10	15	20	25	30	40	50	60	75	—	100	—	—	—		
	1800	Open-Drip	1	1.5-2	3	5	7.5	10	15	20	25	30	40	50	60	75	100	125	150	200	—	—	
		TEFC Expl. Proof	1	1.5-2	3	5	7.5	10	15	20	25	30	40	50	60	75	—	100	125	—	150-200		
	1180	Open-Drip	—	1	1.5	2	3	5	7.5	10	15	20	25	30	40	50	60	75	100	125-150	—	—	
		TEFC Expl. Proof	—	1	1.5	2	3	5	7.5	10	15	20	25	30	40	50	60	75	100	—	125-150		
Weight — Lbs. (kg)	3600	Open-Drip	52 (24)	52 (24)	75 (34)	85 (39)	125 (57)	150 (68)	245 (111)	305 (138)	320 (145)	340 (154)	530 (236)	570 (254)	620 (281)	655 (297)	855 (388)	930 (422)	1060 (481)	—	—		
		TEFC Expl. Proof	30 (14)	35 (16)	60 (36)	95 (43)	135 (61)	155 (70)	210 (95)	250 (113)	460 (209)	480 (218)	680 (313)	715 (324)	980 (445)	1020 (463)	1320 (599)	—	—	—	—	—	
		1800	Open-Drip	75 (34)	75 (34)	75 (34)	85 (39)	125 (57)	150 (68)	245 (111)	305 (138)	320 (145)	340 (154)	520 (236)	570 (259)	620 (281)	655 (297)	855 (388)	930 (422)	1335 (606)	1435 (651)	—	—
			TEFC Expl. Proof	120 (54)	128 (58)	164 (74)	200 (91)	308 (140)	351 (164)	381 (173)	410 (186)	622 (282)	640 (290)	885 (401)	910 (413)	1195 (542)	1470 (667)	—	1700 (771)	1800 (816)	—	2100 (953)	—
		1180	Open-Drip	—	75 (34)	75 (34)	75 (34)	85 (39)	145 (66)	245 (111)	305 (138)	320 (145)	340 (154)	520 (236)	570 (259)	620 (281)	655 (297)	855 (388)	930 (422)	1335 (606)	1435 (651)	—	—
			TEFC Expl. Proof	—	35 (16)	80 (36)	95 (43)	135 (61)	155 (70)	210 (95)	250 (113)	460 (209)	480 (218)	680 (313)	715 (324)	980 (445)	1020 (463)	1320 (599)	1610 (730)	1800 (816)	—	2300 (1040)	—

Horizontal API-610 Process Pumps

Goulds makes a line of high temperature/ high pressure horizontal process pumps designed and built to API-610. Available in both end suction and top section designs. Goulds models 3700 and 3710 provide capacities to 7500 GPM (1700 m³/h) with heads to 1000 feet (305 m), temperatures to 800° F (427° C) and pressure to 870 PSIG (6000 kPa).

Ask for Goulds Bulletin 724.1 for more information.



Model 3700 End Suction
API-610 Pump

Packaging - Processing

Bid on Equipment

1-847-683-7720

www.bid-on-equipment.com

Dimensions Model 3900

All dimensions in inches and (mm). Not to be used for construction.

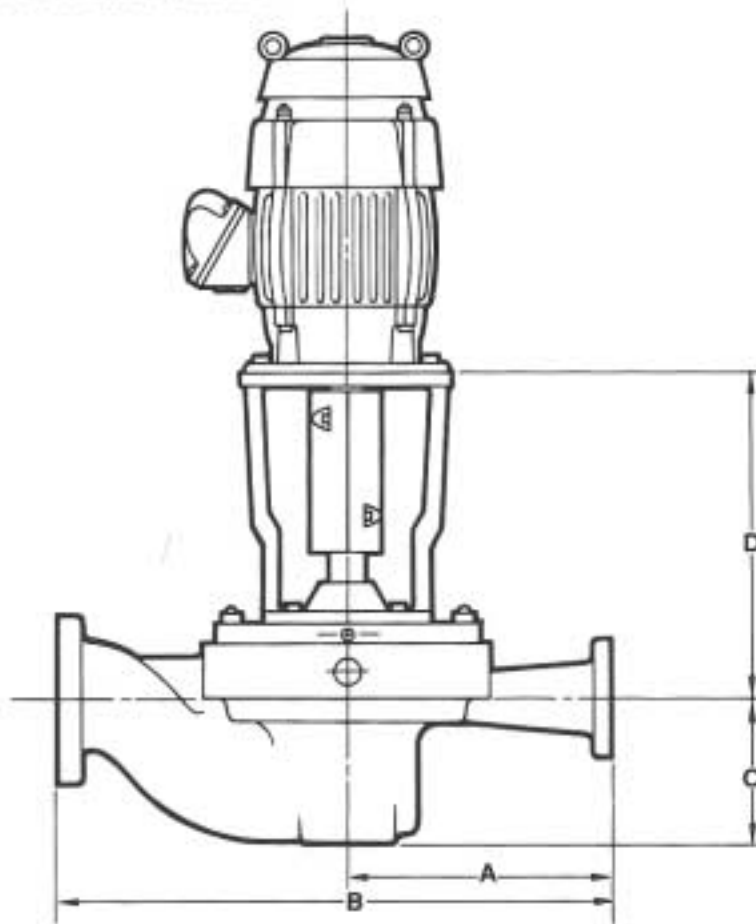

DIMENSIONS DETERMINED BY PUMP

Frame	Pump Size	A	B	C	D	Weight — Lbs. (kg)
S	1½x2-7	9.75 (248)	19.50 (495)	6.00 (152)	18.25 (464)	272 (123)
	1½x3-7	9.75 (248)	19.50 (495)	7.00 (178)	18.62 (473)	276 (125)
	2x4-7	11.00 (279)	21.00 (533)	8.00 (203)	18.75 (476)	280 (127)
	3x4-7	11.50 (292)	23.00 (584)	8.25 (210)	18.75 (476)	286 (129)
	4x6-7	11.75 (298)	26.00 (660)	8.75 (222)	18.62 (473)	425 (193)
	1½x2-9	10.50 (267)	21.00 (533)	6.62 (168)	18.25 (464)	308 (140)
	1½x3-9	11.00 (279)	22.50 (572)	7.88 (200)	18.25 (464)	310 (141)
	2x4-9	12.00 (305)	24.00 (610)	7.88 (200)	18.38 (467)	316 (143)
	3x6-9	13.50 (348)	25.00 (635)	10.25 (260)	18.38 (467)	514 (233)
	4x6-9	15.50 (394)	30.50 (775)	10.31 (262)	18.50 (470)	477 (218)
	1½x3-11	12.50 (318)	25.00 (635)	7.38 (187)	18.25 (464)	366 (166)
M	2x4-11	12.00 (305)	24.00 (610)	9.00 (229)	19.62 (498)	422 (191)
	3x6-11	14.50 (368)	29.50 (749)	6.75 (171)	19.75 (502)	503 (228)
	4x6-11	17.00 (432)	33.50 (851)	12.50 (318)	19.06 (484)	529 (240)
	6x8-11	18.25 (464)	36.75 (933)	12.38 (314)	19.38 (492)	890 (404)
	2x3-13	13.75 (349)	27.25 (692)	9.25 (235)	19.12 (486)	619 (281)
	3x6-13	14.25 (362)	28.75 (730)	10.69 (272)	19.12 (486)	694 (315)
	4x6-13	17.25 (438)	35.25 (895)	9.00 (229)	19.25 (489)	754 (342)
	6x8-13B	23.00 (584)	43.75 (1111)	14.75 (375)	19.56 (497)	1464 (664)
L	6x8-13A	21.00 (533)	40.00 (1016)	14.95 (380)	19.88 (505)	821 (372)
	3x4-16	16.50 (419)	33.00 (838)	11.06 (281)	20.00 (508)	945 (429)
	4x6-16	17.25 (438)	34.50 (876)	12.94 (329)	20.00 (508)	1010 (458)
	6x8-16A	21.00 (533)	42.50 (1080)	10.00 (254)	20.12 (511)	1273 (577)
	6x8-16B	23.00 (584)	44.00 (1118)	17.88 (454)	20.19 (513)	1480 (671)
	8x10-16	26.00 (660)	53.00 (1346)	17.88 (454)	20.50 (521)	2436 (1105)
	10x12-16	28.75 (730)	61.75 (1568)	20.00 (508)	21.00 (533)	3443 (1562)
XL	8x10-21	27.50 (699)	55.75 (1416)	13.25 (336)	20.88 (530)	2596 (1176)
	10x12-21	33.00 (838)	63.00 (1600)	23.75 (603)	21.00 (533)	2880 (1308)