

CCW-Z-214W-WP

This waterproof weigher can be washed down, making it ideal for weighing frozen foods, meat, poultry, seafood and other high moisture products. Its durable construction meets international waterproof standards IP65 and USDA approval.



Standard Type Weigher



Waterproof Type



Plasma Touch Screen



Stepping Motor



System Engineered



Easy Cleaning and Maintenance

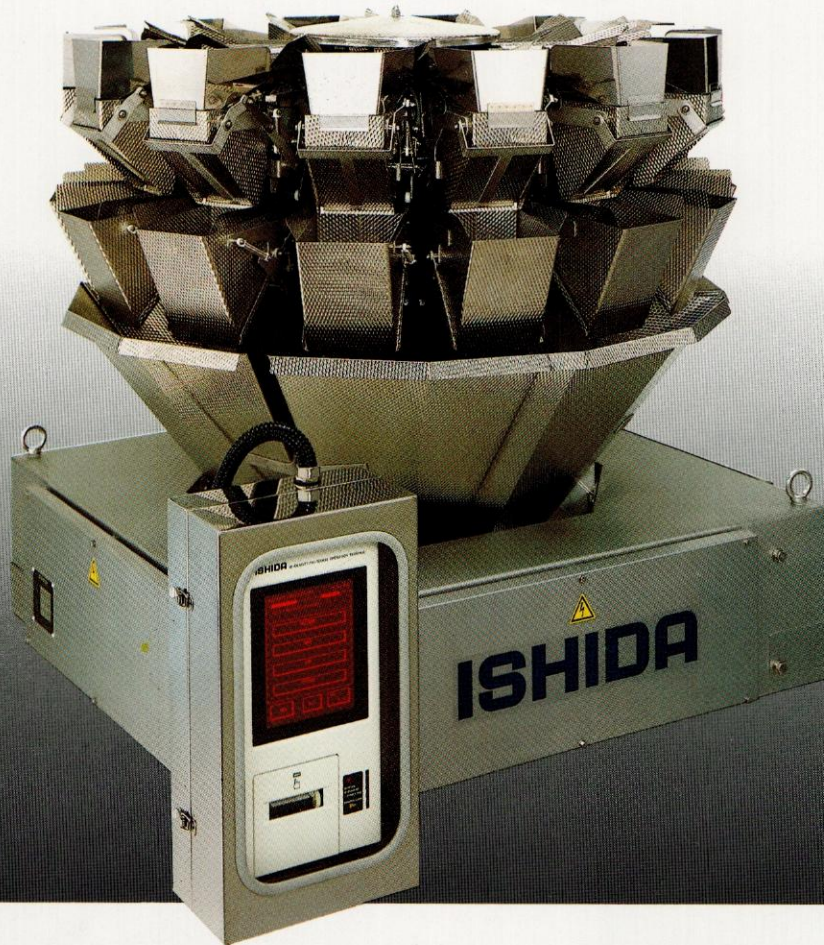

DIMENSIONS

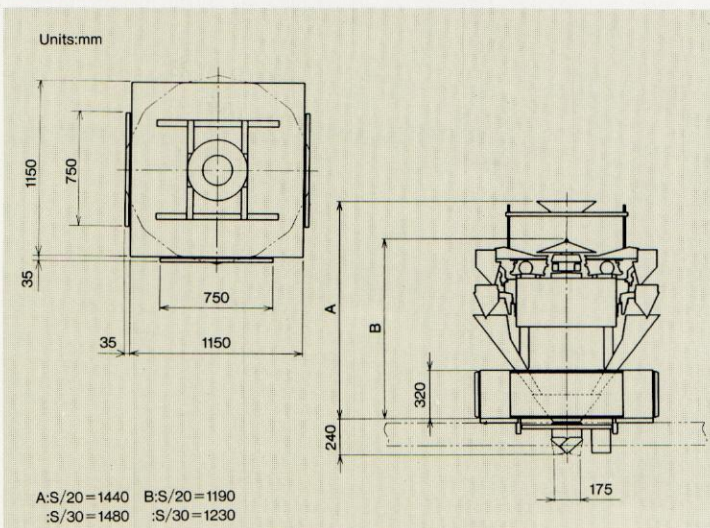

SPECIFICATIONS

Model	CCW-Z-214W-S/20-WP		CCW-Z-214W-S/30-WP	
Weighing Capacity	500g	1,000g	500g	1,000g
Weighing Range	14g to 500g	25g to 1,000g	14g to 500g	25g to 1,000g
Accuracy for Single Product (*)	$\bar{X} < 1.0g$ (Max.)	$\bar{X} < 2.0g$ (Max.)	$\bar{X} < 1.0g$ (Max.)	$\bar{X} < 2.0g$ (Max.)
Maximum Volume for Weighing	3,000 cc (per single dump)		4,500 cc (per single dump)	
Weighing Speed(**)	up to 100 W.P.M.		up to 90 W.P.M.	
Controller	16 bit microprocessor			
Weigh Cell	Double-beam strain gauge load cell			
Target Weight Setting	Digital entry via touch screen panel			
Weight Display	(Minimum Graduation)		(Minimum Graduation)	
	0.1g	0.2g	0.1g	0.2g
Air Purge Supply	Plasma			
Material	Required air pressure - 5kgf/cm ² , 90 liters/min. (Equivalent to 2.2 kw compressor) Air hose - PT3/8" (for air dryer connection) NOTE: Air compressor must be provided by the end user.			
Options	Main body - SUS 304, drive unit - anodized coating Dispersion feeder unit frame - SUS 303 Radial feeder unit frame - SUS 303			
	Various options are available. Please contact Ishida distributors.			

NOTE: Specifications subject to change without notice.

(*) : Depends on target weight, weighing speed and conditions.

(**) : Depends on product shape, product density, target weight, etc.