

# ESL Bottle Sanitizer

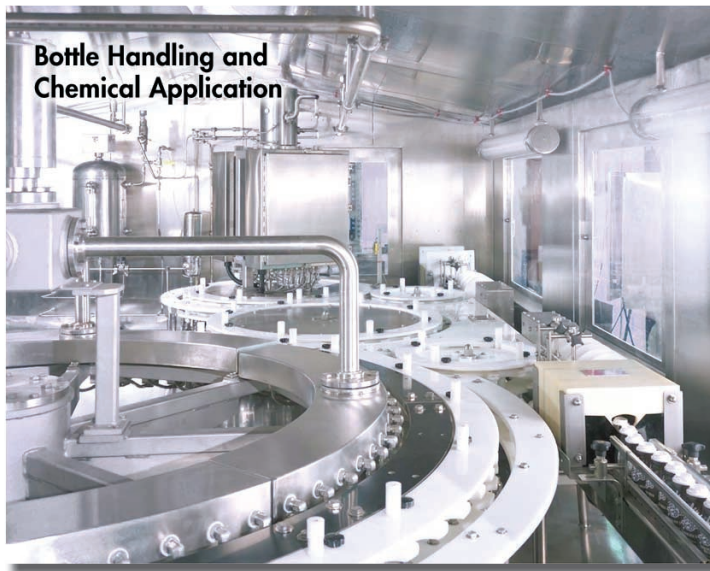

integrated  
packaging  
machinery, LLC

**ESL**



Bottle Handling and  
Chemical Application

The **Extended Shelf Life Bottle Sanitizer (ESL)** creates a new definition of Quality Bottling by extending the actual shelf life of your products.



Sterile Air Unit



Chemical Spray Nozzles



Sterile Air Drying Nozzles

Packaging - Processing  
**Bid on Equipment**

1-847-854-8577

[www.bid-on-equipment.com](http://www.bid-on-equipment.com)

# ESL Bottle Sanitizer

# ESL

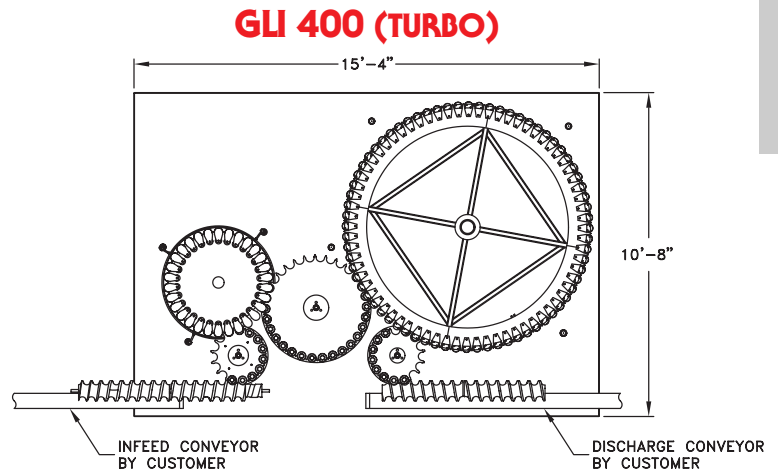
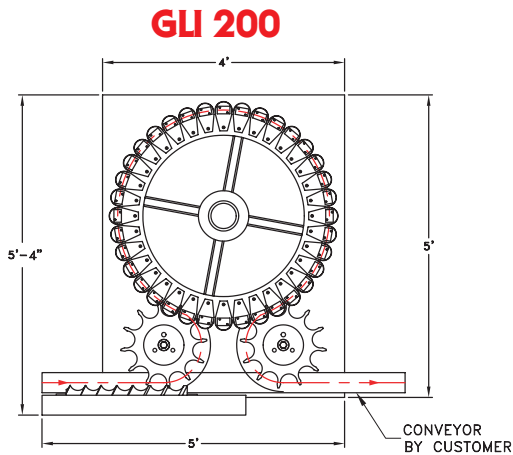

## ESL Bottle Sanitizer Benefits:

- Enclosed design creates a completely controlled environment
- Higher standard of sanitation
- CIP Spray Ball ensures a consistent reliable sanitation
- PLC Monitored & Controlled (Allen Bradley Touchscreen)
- Increases customer distribution network
- Speeds up to 400 bottles per minute

## Air Skid Option:

- Provides sterile air for drying containers
- Improves overall machine air quality
- Steam sterilization of filters to assure air quality
- PLC Monitored & Controlled Filter
- Less complex installation

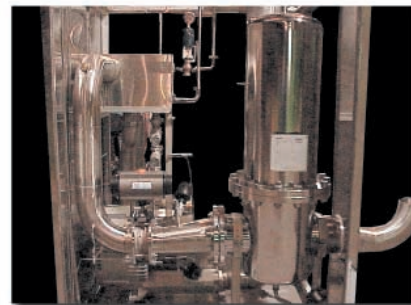

Featuring a Sterile Air Skid Option



**integrated packaging machinery, LLC**

3790 28th Street, SW • Grandville, MI 49418

Tel: 616-531-7758 Fax: 616: 616-531-7797

[www.callipm.com](http://www.callipm.com)

Packaging - Processing  
**Bid on Equipment**

1-847-854-8577

[www.bid-on-equipment.com](http://www.bid-on-equipment.com)