

IDEAL

Designers and Manufacturers of Quality Packaging Equipment

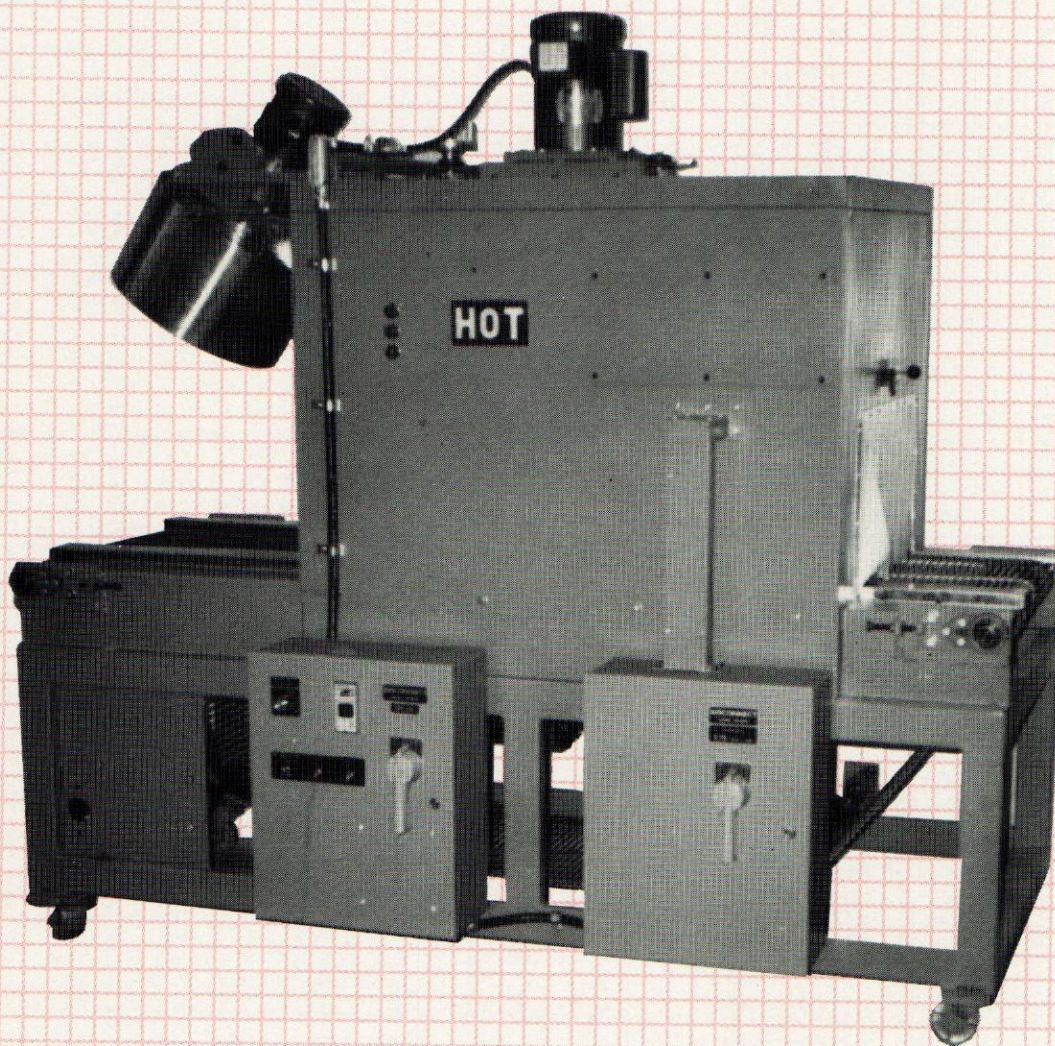

AIR FLOW SHRINK TUNNEL

Produces skin tight packages with all types of shrink film

800 SERIES

Packaging - Processing
Bid on Equipment

1-847-683-7720

www.bid-on-equipment.com

AIR FLOW SHRINK TUNNEL

Produces skin tight packages with all types of shrink film

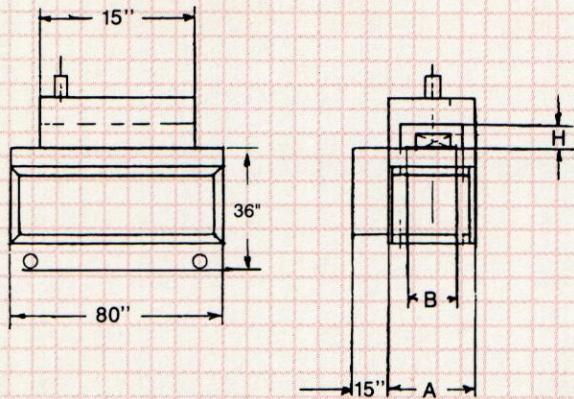

	1	2
H	6	12

MACHINE WIDTH	20	30
FRAME WIDTH A	33	43
BELT WIDTH B	18	28

OPERATION MODE

Any product wrapped and sealed in shrink film enters onto the SHRINK TUNNEL conveyor. The conveyor moves the product into a heated hood. In the hood directed and controlled hot air causes the film to shrink around the product. The final result is a very tight skin around the package.

FEATURES

- VARIABLE CONTROLS:
- 1 - Conveyor speed.
 - 2 - Temperature up to 550° F.
 - 3 - Hot air direction - Combination of Bottom side and Top.
 - 4 - Height 36" adjustable lags included.

- TYPES OF CONVEYORS:
- 1 - Teflon mesh belt
 - 2 - Steel mesh belt
 - 3 - Roller conveyor, Live - Dead

TYPES OF WRAPPING

- 1 - Sleeves: By a sleeve wrapper automatic or manual
- 2 - Full wrap:
 - By Ideal Bagger 2420
 - Ideal L Sealer 2520
 - Ideal automatic L-Sealer ALS 2500
 - Ideal Sleeve Wrapper with side seals

PERFORMANCE

The fact that this Ideal Shrink Tunnel is built with many variable controls and comes with many other options, makes a very versatile unit capable of handling all shrink films.

SPECIFICATION

ELECTRICS *	ACCORDING TO CUSTOMER SPECIFICATIONS	HEATING CAPACITY	ACCORDING TO TUNNEL DIMENSIONS 12 - 20 KW
SIZES	SEE DWG		

Packaging - Processing
Bid on Equipment

1-847-683-7720
www.bid-on-equipment.com

Head Office: 4701 Rivard St.
Montreal, Quebec, Canada H2J 2N5



Telephone: 514 / 845-9291
TELEX: North America CA7607901
Overseas CA230-7607901
FAX: 514 / 845-2652