

**Material recovery systems
for wire and cable,
extrusion blow molding and
compounding operations.**

HMG[®] HOT MELT GRANULATORS

Performance Features

- Unique chamber design allows air cooling of hot granulate for fast throughput without clogging.
- Quiet operation — 85 dbA or less in most applications.
- Recovers most hot materials at up to 600°F without pre-cooling.
- Safe 120-volt control circuit; hopper and screen cradle electrically interlocked.
- Available as complete systems with blower evacuation and cyclone separating equipment for automated materials handling and closed loop processing.



*Swing down screen cradle
and hinged top panel for easy
access, cleaning and service.*

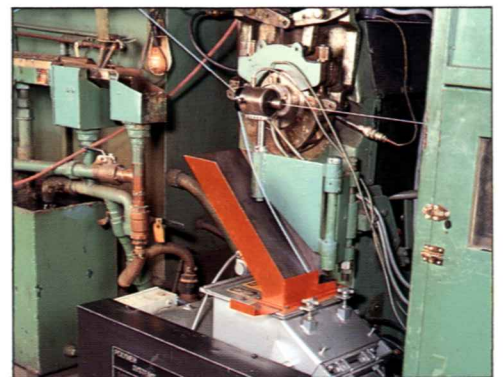
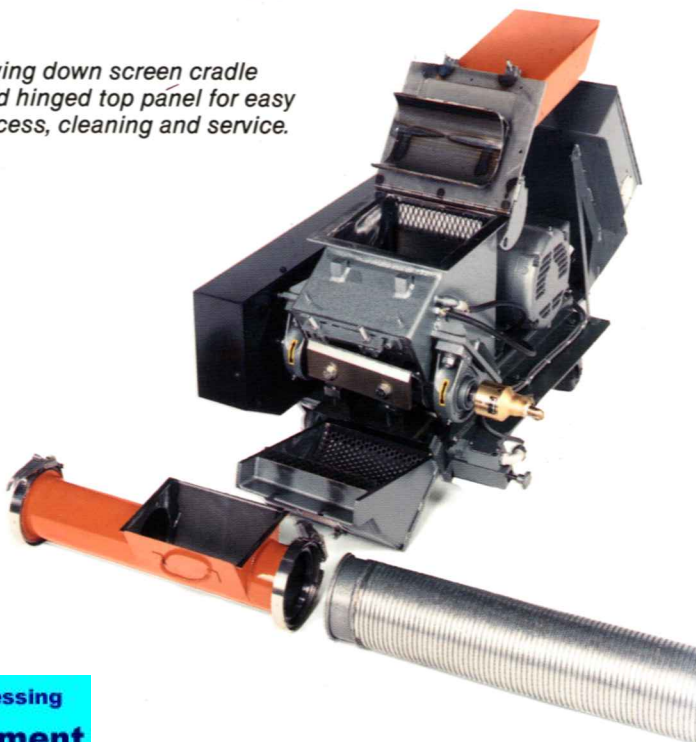

Manufacturers of FEP, PVC- and PE-insulated and jacketed wire and cable have successfully blended up to 50% recovered material with virgin pellets with no loss of physical or dielectric properties by immediately granulating hot material at the processing station.

POLYMER SYSTEMS
SIZE REDUCTION EQUIPMENT

Packaging - Processing

Bid on Equipment

1-847-683-7720

www.bid-on-equipment.com

NO STICKING OR CLOGGING.

HMG[®] machines feature a modified Shurfeed™ cutting chamber specially designed for recovery of hot plastics up to 600°F without pre-cooling. Hot extrudate falls directly in front on the rotating knives and is passed through the cutting action immediately. The evacuation blower provides high volume air flow through the open rotor and expanded chamber area to cool material quickly. Close, uniform rotor-to-screen clearance and the scissors-cut blade configuration produce fast, positive throughput without material build-up in the chamber.

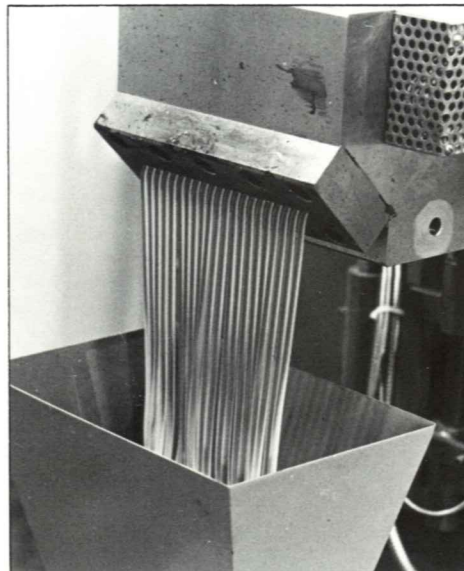

For certain compounding applications, HMG[®] machines can provide a low-cost, space-saving alternative to water bath and strand pelletizing systems. Resulting granulate can be processed immediately, and the water-free system is particularly applicable to compounding of hygroscopic materials.

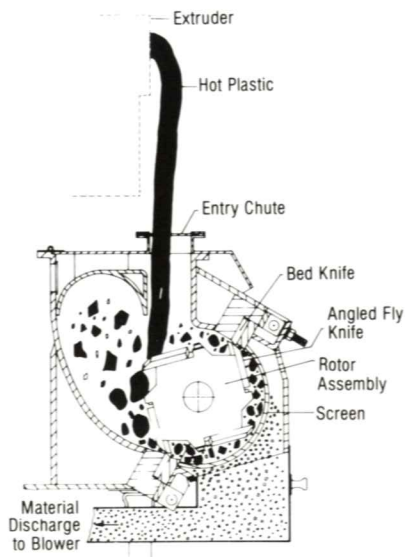

HMG[®] systems are **complete** in every detail including granulator, blower, cyclone separator and related ductwork. All system components are sized and matched to meet specific application requirements. Soundproof enclosures for granulators and blowers are also available to reduce operating noise levels.

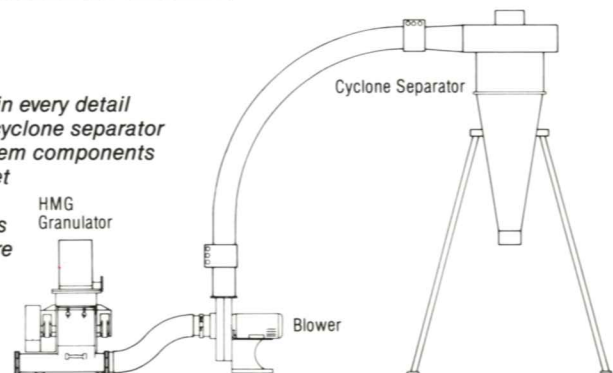

DIMENSIONS

MODEL	A	B	C	D*	E	F	G
HMG 88	inches 14 (mm) (355)	26 (660)	17 (432)	3 (75)	14.5 (368)	24 (610)	11 (279)
HMG 1010	inches 27 (mm) (686)	48 (1220)	23 (584)	5 (125)	19 (483)	23.5 (597)	9.5 (241)
HMG 1627	inches 30 (mm) (762)	61 (1549)	37.5 (952)	8 (200)	28 (711)	51 (1295)	21.5 (546)

*Outside diameter

SPECIFICATIONS

MODEL	HMG 88	HMG 1010	HMG 1627
Throughput*	lbs/hr 100 (kg/hr) (45)	400 (180)	1200 (540)
Throat size of chamber	inches 8 x 8 (mm) (203 x 203)	10 x 10 (254 x 254)	16 x 27 (406 x 686)
Feed opening	inches 4 x 2 (mm) (102 x 51)	9 x 3 (229 x 76)	24 x 3 (610 x 76)
Cutting circle	inches 7.6 (mm) (193)	9.5 (241)	14.75 (375)
Rotor knives	2	4	5
Bed knives	2	2	2
Motor	HP 5 (kw) (3.7)	7.5-10-15 (5.6-7.5-11)	50 (37)
Blower	HP 1.5 (kw) (1.1)	3-5-7.5 (2.2-3.7-5.6)	7.5 (5.6)
Shipping weight	lbs 900 (kg) (410)	1200 (545)	5600 (2545)

*The above are CONSERVATIVE throughput rates based on HDPE. Type of process and material can greatly affect throughput rates.
 HMG[®] machines are designed and manufactured in the U.S.A. Specifications subject to change without notice.

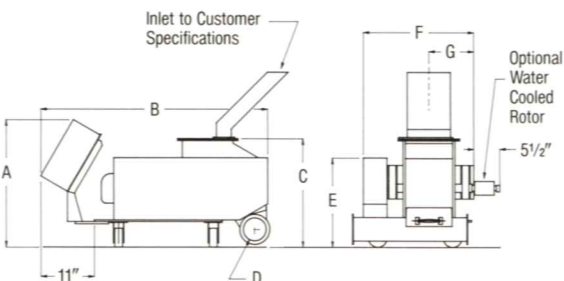

We encourage and support recycling efforts.



Hosokawa Polymer Systems

63 Fuller Way
 Berlin, CT 06037-1540
 Tel: (860) 828-0541 • Fax: (860) 829-1313



HOSOKAWA POLYMER SYSTEMS

Hosokawa Polymer Systems is a member of the Hosokawa Micron Group, responding to global needs through an emphasis on materials science and engineering. The Group is an international provider of equipment and systems for powder and particle processing, product recovery, plastic processing and confectionery products. The Group maintains facilities for research, engineering, manufacturing, and service in each of the world's major industrial markets.

Visit our Web site at: <http://www.hosokawamicron.com>



POLYMER HOT MELT GRANULATOR™ SYSTEMS

THROUGHPUT RATES IN LBS/HOUR

<u>Material</u>	<u>HMG™ 88</u>	<u>HMG™1010</u>	<u>HMG™1627</u>
LDPE	30	150	600
HDPE	100	400	1200
POLYPROPYLENE	20	100	250
PVC	100	400	900
ABS	20	75	300

The above are *conservative* throughput rates.

The granulation of hot plastic resins is a highly specialized field. There are many factors which determine the actual rates which can be obtained. Some of the factors which control throughput are:

Material, specific gravity and bulk density: Additives such as slip agents, pigments, fire retardants, blowing agents, lubricants, plasticizers, fillers and extenders, etc.

Type of process: Extrusion blow molding, wire and cable insulation, compounding, two roll mill, temperature at which material is processed.

The way in which the Hot Melt Granulator is fed: Continuous when fed from two roll mill, strand, cross-head, sheet or ribbon die, compared to surge feeding such as manual feed from blow molding bleed or parisons or lumps from extruder purging.

The way the HMG™ is equipped: Horsepower of grinder motor, size of blower/cyclone system, whether provided with water cooled rotor and cutting chamber, temperature of cooling water, type of infeed hopper, etc.