



WEP-80 Wide Belt Elevating Prefeeder

Designed for Large Parts Loading



Product Overview:

Hoppmann's WEP-80 elevating prefeeder is specially designed to handle large parts. Two independently controlled variable speed drives ensure gentle product metering. Designed for floor level parts loading, the 80 cubic foot capacity hopper delivers product at an average belt speed of 23 feet per minute. The cleated elevator belt has a nominal cleat height of 3" and a cleat pitch of 12", allowing for maximum product loading.

Product Specifications:

	<u>ANSI</u>	<u>Metric</u>
A. Overall Height	98"	2489mm
B. Overall Width	72"	1829mm
C. Overall Length	136"	3454mm
D. Dump Height (Adjustable)	58"	1473mm
E. Hopper Load Height	50"	1270mm

Standard Models:

Part Number	<u>WEP80XXDSA</u>	<u>WEP80XXASA</u>
Motor Style	DC	AC
Horsepower—Horizontal Belt	1/4 hp	186 W
Horsepower—Elevator Belt	1/2 hp	373 W
Motor Voltage	90V	180V
Total Equipment Weight	2462 lbs	1117 kg
Hopper Capacity	80 ft ³	2266 liters

Standard Features:

- All stainless steel construction
- Sensor controlled dual belt metering system
- Horizontal belt is FDA/USDA approved white buna-n/polyester polyflake endless belting
- Elevator belt is FDA/USDA approved white 1-ply solid woven polyester fabric with .156" thick white PVC coating and PVC cleats
- Panel mount controller card
- Mechanical style level sensor mounting kit – proximity sensor not included (P/N LEVSENPKG1)

Available Options:

- Elevator extensions*
- Continuous welded hopper seams
- Elevator/hopper covers
- Modular plastic chain upgrade
- Washdown motors
- NEMA 1 encased controller
- Clean out doors
- Casters

*It is strongly recommended that the frame of the prefeeder be reinforced and/or additionally supported for elevator extensions of 72" or greater.

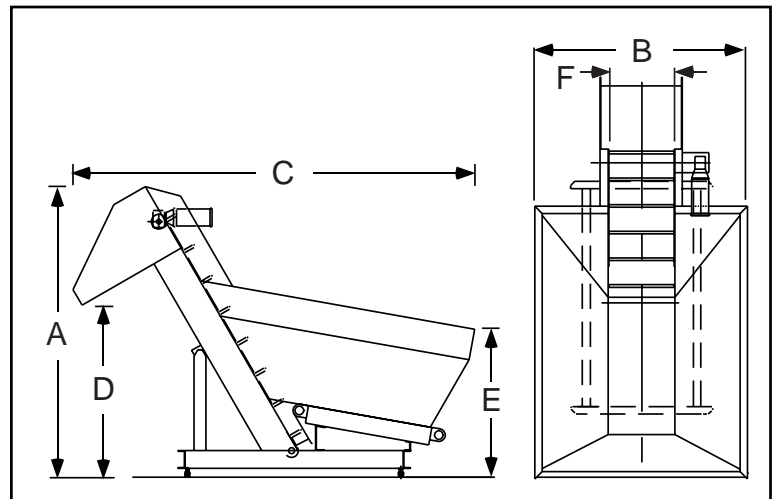

Hoppmann Corporation strives to improve its products and reserves the right to change or discontinue specifications & designs shown in this brochure without notice and without incurring obligation. 06/05