

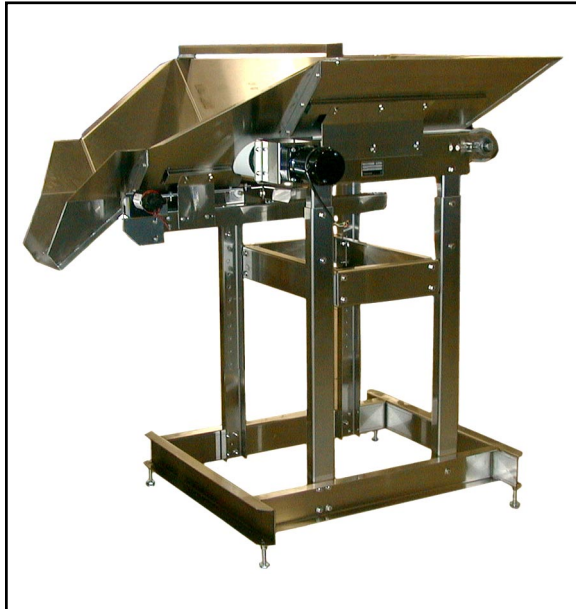

## WB-6 Wide Belt Prefeeder Designed for Fragile Parts Loading



### Product Overview:

Hoppmann's WB-6 prefeeder is specially designed to handle fragile parts. Two independent variable speed drives and a standard level sensor ensures gentle product metering. Product drops from the upper belt to the lower belt where it is pulled away at a faster rate to assist in part separation and detangling.

### Product Specifications:

	ANSI	Metric
A. Overall Width	51"	1295mm
B. Overall Length	72"	1829mm
C. Dump Height (adjustable)	48"±10"	1219mm±254
D. Load Height (adjustable)	74"±10"	1880mm±254
E. Angle of Feed	0°-11°	0°-11°

### Standard Models:

Part Number	WB06XXXDSA
Motor Style	DC
Horsepower - Upper Belt	1/8 hp/93 W
Horsepower - Lower Belt	1/30 hp/25 W
Motor Voltage	90V
Total Equipment Weight	650 lbs/295 kg
Supply Hopper Capacity	6 ft <sup>3</sup> /170 liters

### Standard Features:

- All stainless steel construction
- Adjustable feed angle
- Sensor controlled dual belt metering system
- FDA/USDA approved white buna-n/polyester polyflake endless belting (upper belt)
- Durable reinforced black neoprene belt with fiberglass cord (lower belt)
- Panel mount controller card
- Mechanical style level sensor mounting kit – proximity sensor not included (P/N LEVSENPKG1)

### Available Options:

- Continuous welded hopper seams
- Washdown motors
- NEMA 1 encased controller
- Hopper covers
- Casters

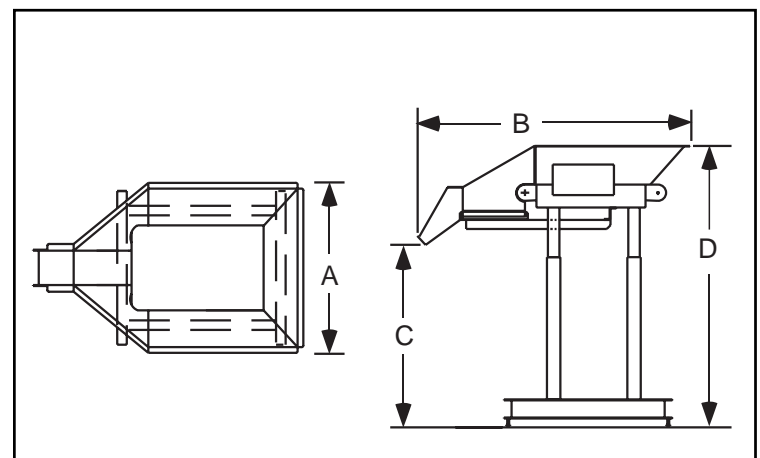

Hoppmann Corporation strives to improve its products and reserves the right to change or discontinue specifications & designs shown in this brochure without notice and without incurring obligation. 06/05

**Packaging - Processing**  
**Bid on Equipment**  
 1-847-683-7720  
[www.bid-on-equipment.com](http://www.bid-on-equipment.com)

**Hoppmann Corporation Headquarters**  
 13129 Airpark Drive • Suite 120 • Elkwood, VA 22718  
 Tel: 540.829.2564 • 800.368.3582 • Fax: 540.829.1724  
[www.hoppmann.com](http://www.hoppmann.com) • email: [feeder@hoppmann.com](mailto:feeder@hoppmann.com)

**Hoppmann Corporation Manufacturing**  
 P.O. Box 879 • 291 Dillard Rd. • Madison Heights, VA 24572  
 Tel: 434.929.4746 • 800.543.0915 • Fax: 434.929.4959  
[www.hoppmann.com](http://www.hoppmann.com) • email: [feeder@hoppmann.com](mailto:feeder@hoppmann.com)