



# Shibuya Hoppmann

## Model WB-6 Prefeeder

### *ANSI/Metric Installation & Maintenance Manual*



**Refer all servicing to qualified personnel.**

*This manual is intended for use by qualified mechanics and electricians who install and/or service the WB-6 Prefeeder.*

*Please copy this information from the WB-6 Prefeeder's serial plate.*



Model Number:

Serial Number/Date:

Inventory Number (Check One):

- WB06XXXDCA
- WB06XXXDCM
- WB06XXXDSA
- WB06XXXDSM

First Edition, Revision 1, All Rights Reserved  
Copyright © 2007 by Shibuya Hoppmann Corporation.

13129 Airpark Drive, Suite 120  
Elkwood, Virginia 22718

**Phone:** (540) 829-2564

Toll Free: (800) 368-3582

**Fax:** (540) 829-1724

www.hoppmann.com • email: publications@hoppmann.com



# Quick Start

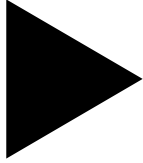

## About this Manual

**Overview** This manual is written, as a guideline, to aid qualified personnel in the installation and/or maintenance of the WB-6 Prefeeder. It is intended to provide a basic understanding of the construction, installation, and maintenance of a WB-6 Prefeeder. All procedures in this manual should be performed by qualified personnel or under their direction.

**Models Covered** This manual covers four models. If you are unsure of your model, locate the inventory number on the serial plate of the prefeeder.

<i><b>Inventory No.</b></i>	<i><b>ANSI</b></i>
WB06XXXDCA .....	Cold Rolled Steel
WB06XXXDSA .....	Stainless Steel

<i><b>Inventory No.</b></i>	<i><b>Metric</b></i>
WB06XXXDCM .....	Cold Rolled Steel
WB06XXXDSM .....	Stainless Steel

**Caution Symbols and Messages** Caution symbols and messages in this manual call attention to hazardous voltages, moving parts and other hazardous conditions.



The exclamation point caution symbol denotes possible personal injury and/or damage to the equipment.



The lightning bolt caution symbol denotes possible personal injury and/or damage to the equipment from electrical hazards.



# Table of Contents

	Page		Chapter
<b>Quick Start</b>	2	About this Manual	
<b>Prefeeder Description &amp; Specifications</b>	5	The WB-6 Prefeeder: An Overview	<b>1</b>
		<i>Figures</i>	
	5	Figure 1-1. WB-6 Overhead Prefeeder	
	6	Figure 1-2. WB-6 Prefeeder Specifications	
<b>Safety Precautions</b>	7	Warnings	<b>2</b>
	7	Operating & Maintenance: Do's & Don'ts	
<b>Installation &amp; Startup</b>	9	If the Prefeeder is Already Set Up	<b>3</b>
	9	Unpacking and Inspection	
	9	Physical Setup	
	10	Level Sensors	
	11	Establishing the Correct Prefeeder Speeds	
		<i>Figures</i>	
	10	Figure 3-1. Level Sensor Mount Package	
	12	Figure 3-2. DC ANSI Suggested Wiring Diagram (Wide Belt Drive)	
	13	Figure 3-3. DC ANSI Suggested Wiring Diagram (Metering Belt Drive)	
	14	Figure 3-4. DC Metric Suggested Wiring Diagram (Wide Belt Drive)	
	15	Figure 3-5. DC Metric Suggested Wiring Diagram (Metering Belt Drive)	



	<b>Page</b>		<b>Chapter</b>
<b>Repair &amp; Maintenance</b>	17	Belt/Drive Assembly	<b>4</b>
	17	Replacing the Metering Belt	
	18	Replacing the Wide Belt	
	20	Gearmotor Maintenance	
		<b>Figure</b>	
	17	Figure 4-1. Belt/Drive Assembly	
<b>Spare Parts</b>	21	Notice to Shibuya Hoppmann Customers	<b>5</b>
	21	Notice to Dealer and OEM Customers	
	21	In North America	
	22	WB-6 Recommended Spares - ANSI	
	23	WB-6 Recommended Spares - Metric	
	24	Warranty	

# Prefeeder Description & Specifications

## 1

### *The WB-6 Prefeeder: An Overview*

**Function** The WB-6 Prefeeder is designed to load fragile parts into a feeder or other equipment for singulation and /or orientation. The WB-6 is designed as a free-standing floor unit. The "6" refers to the supply hopper capacity of 6 cubic feet. See Figure 1-1 for a diagram of the WB-6 Prefeeder and Figure 1-2 for the WB-6 Prefeeder Specifications.

**Operation of Equipment** Product is loaded, overhead, into a supply hopper. The wide belt, located in the bottom of the supply hopper, moves the product forward. The metering belt, located in the front of the prefeeder, thins out the density of the product being metered into the feeder bowl and normally runs faster than the wide belt. Both belts are controlled by independent product level sensors. This prefeeder is well suited for metering fragile parts.

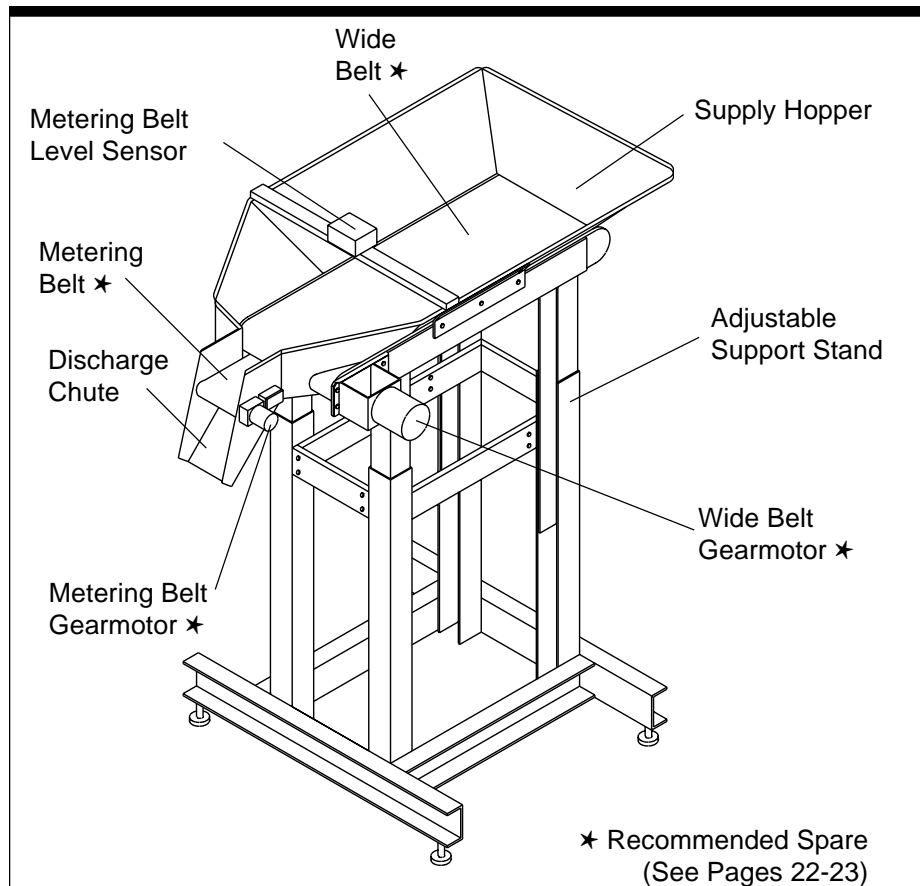

**Figure 1-1. WB-6 Overhead Prefeeder**



**Product Specifications**

**ANSI**

**Metric**

Drive Motor Size - Metering Belt	1/30 HP	25 W
Drive Motor Size - Wide Belt	1/8 HP	93 W
Supply Voltage	115 VAC	240 VAC
Drive Motor Voltage	90 VDC	180 VDC
Power Usage - Metering Belt	1 amp	5 amps
Power Usage - Wide Belt	3 amps	2 amps
Weight	650 lbs	295 kg
Hopper Capacity	6 ft <sup>3</sup>	170 liters

A. Overall Width	51"	1295 mm
B. Overall Length	72"	1829 mm
C. Dump Height (adjustable)	48" ± 10"	1219 mm ± 254 mm
D. Hopper Load Height	74" ± 10"	1880 mm ± 254 mm

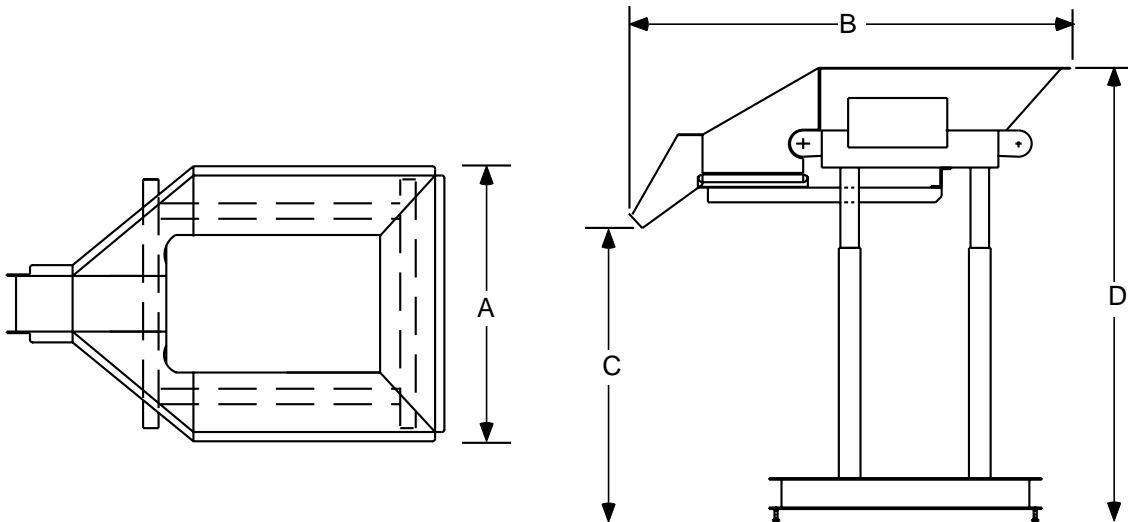

***Your direct supplier may have changed some of these specifications during tooling to better match your application's requirements.***

**Figure 1-2. WB-6 Prefeeder Specifications**

# Safety Precautions

## 2

### Warnings



**Turn Off Power!** Before servicing, make sure you have turned off compressed air and electrical power in a way which prevents accidental reactivation. Padlock and clearly tag the appropriate electrical and pneumatic disconnects. Lockout/tagout procedures are covered in United States Code of Federal Regulation (CFR) Title 29 Part 1910.147, "The Control of Hazardous Energy."



**Dress Appropriately!** Reduce the risk of injury from moving parts by securing loose sleeves and other clothing. Do not wear loose jewelry or neckties near the prefeeder. Wear safety glasses or other protective eyewear when servicing or operating the prefeeder. Never place hands or tools in the prefeeder when it is operating.



**Install Safety Covers!** Make sure the prefeeder remains safe to operate. Be sure all safety covers have all been installed before returning the prefeeder to normal operation. Safety covers on the prefeeder include any covers installed by your direct supplier as well as standard permanent guarding.

### Operating & Maintenance: Do's & Don'ts

**Don't Install the Prefeeder Near Flammable Gas, Vapor or Dust.** You must install additional approved explosion-proof or dust ignition-proof enclosures if installation occurs under these conditions. Without such additional enclosures, normal sparking of the brushes inside the motor could ignite flammable gas, vapor or dust.

**Do Use the Same or Identical Mounting Screws if Replacing the Motor.** If longer mounting screws are used, they may come into contact with parts of the motor that conduct electricity.

# Installation & Startup

## 3

### ***If the Prefeeder is Already Set Up***

If you buy a Shibuya Hoppmann prefeeder as part of a Shibuya Hoppmann feeder system, then your direct supplier will have performed all the procedures in this chapter. You will still need to:

- ▶ **Position your Prefeeder.** Follow the equipment layout drawing provided by your direct supplier.
- ▶ **Connect Electrical Wiring.** Follow as-built electrical diagrams provided by your direct supplier.
- ▶ **Make Pneumatic Connections.** If your prefeeder has a hopper agitator, your direct supplier will give you setup specifications.
- ▶ **Install and Test the Rest of the System.** Installation is complete.

*If the Shibuya Hoppmann prefeeder is drop-shipped to your location, follow the procedures in this chapter to finish setting up the prefeeder.*

### ***Unpacking and Inspection***

**Step 1—Inspect and Unpack the Crate.** Remove packing materials from sensors, tooling and moving parts. Make a visual check to be sure parts have not come loose during shipping. If you find any concealed damage, call the shipping carrier and your direct supplier immediately. ***Do not attempt to fix the problem yourself unless told to do so by your direct supplier.***



**Step 2—Record Serial Number of Prefeeder.** If you have not already done so, record the prefeeder's model and serial number on the front of this manual. *This information is necessary when ordering replacement parts or service.*

### ***Physical Setup***

**Step 1—Position the Prefeeder.** Place the prefeeder as shown on the equipment layout drawing provided by your direct supplier.

*Continued* ▶



**Step 2—Position the Prefeeder.** If you are using a Shibuya Hoppmann Centrifugal Feeder, position the prefeeder so discharged products fall halfway between the center and the outside of the bowl, opposite from the point where products load onto the rim for qualification (refer to Shibuya Hoppmann Centrifugal Feeder manual). Avoid positioning the prefeeder in a way that allows products to bounce up onto the rim of the bowl, disturbing already oriented products. If you are not using a Shibuya Hoppmann Centrifugal Feeder, follow the equipment layout drawing provided by your direct supplier, or the prefeeder may not operate correctly. Level the unit by adjusting the leveling feet and tighten the locknuts.

**Step 3—Connect Power and Air.** Connect the prefeeder to power and compressed air (if applicable). Do not change the prefeeder's main air regulator; it should already be correct when you receive the feeder.

## ***Level Sensors***

### **Metering Belt Level Sensor**



**Figure 3-1. Level Sensor Mount Package**

The amount of product exiting the bulk supply hopper is controlled by the metering belt level sensor. This sensor is located in the electro-mechanical switch mounted on top of the bulk supply hopper. The speed of the wide belt allows for a consistent flow of product to be metered onto the metering belt. A level sensor mounting package has been provided with your prefeeder (see Figure 3-1); however, the package does not include a proximity sensor. The proper proximity sensor is a standard 8 mm diameter threaded sensor (choice of sensor dependent on electrical system specifications). For further information contact Hoppmann Corporation or your direct supplier.

*Continued* ►

**Bowl Level Sensor**

The bowl level sensor controls the flow of product entering into the centrifugal feeder or other equipment. This sensor is mounted inside of the feeder bowl or other equipment. The speed of the metering belt, usually twice as fast as the wide belt, thins out the product before entering into the feeder bowl. A level sensor mounting package has been provided with your prefeeder (see Figure 3-1); however, the package does not include a proximity sensor. The proper proximity sensor is a standard 8 mm diameter threaded sensor (choice of sensor dependent on electrical system specifications). For further information contact Shibuya Hoppmann Corporation or your direct supplier.

### ***Establishing the Correct Prefeeder Speeds***

To establish the correct prefeeder speeds, turn both speed controllers to  $\frac{1}{4}$  their maximum settings. Observe the flow of product from the bulk supply hopper to the metering belt and from the metering belt to the feeder. Only allow enough product to exit the bulk supply hopper that will keep the level of product on the metering belt relatively consistent. ***This will help to prevent overfeeding the metering belt with product and possible product jams of the prefeeder.*** Once product begins to exit the centrifugal feeder or other equipment, determine the output rate of your prefeeder. Adjust either speed controller to obtain the desired output rate. To obtain a valid rate, count product as it exits the equipment for at least one minute.



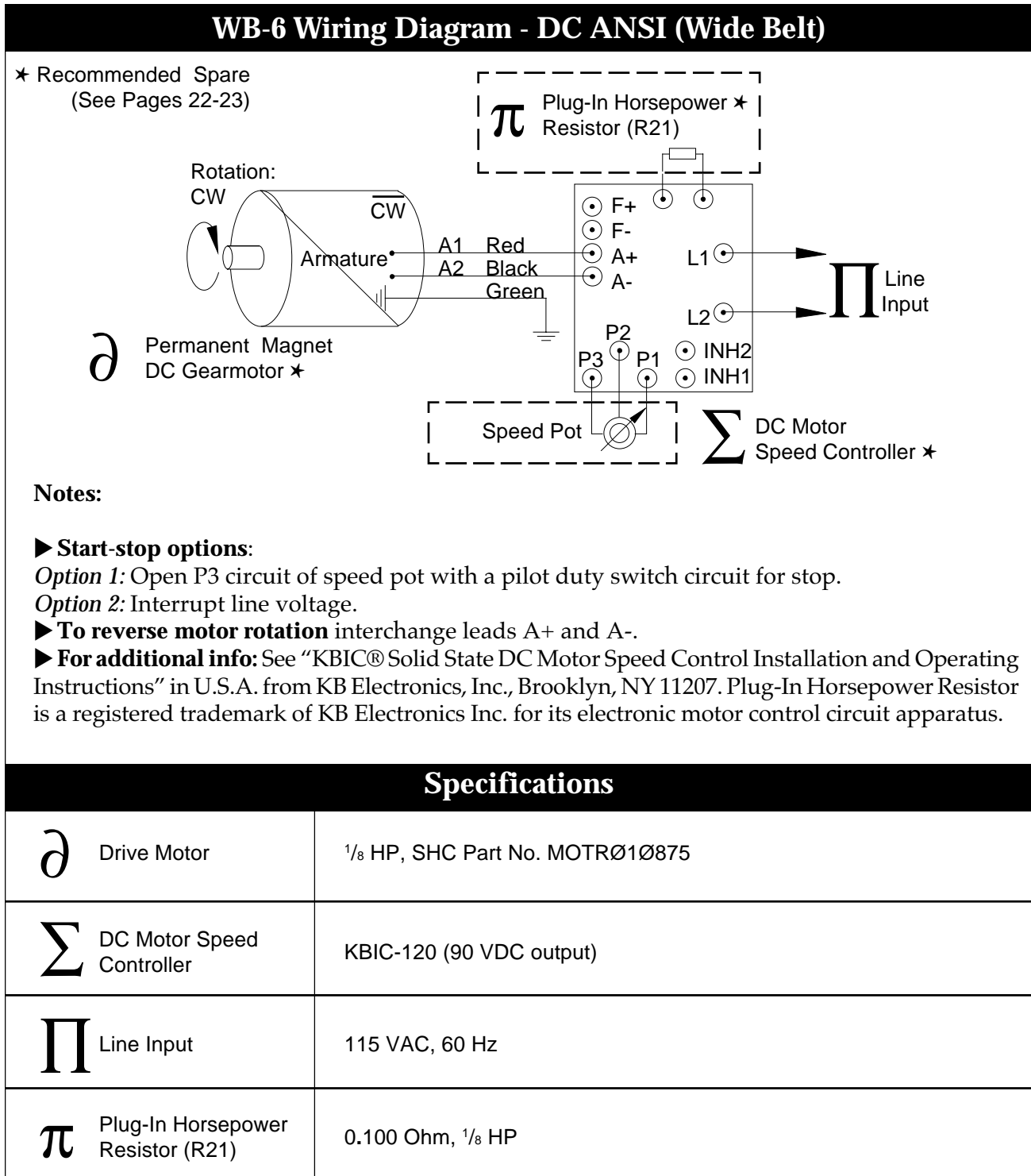

Figure 3-2. DC ANSI Suggested Wiring Diagram (Wide Belt Drive)

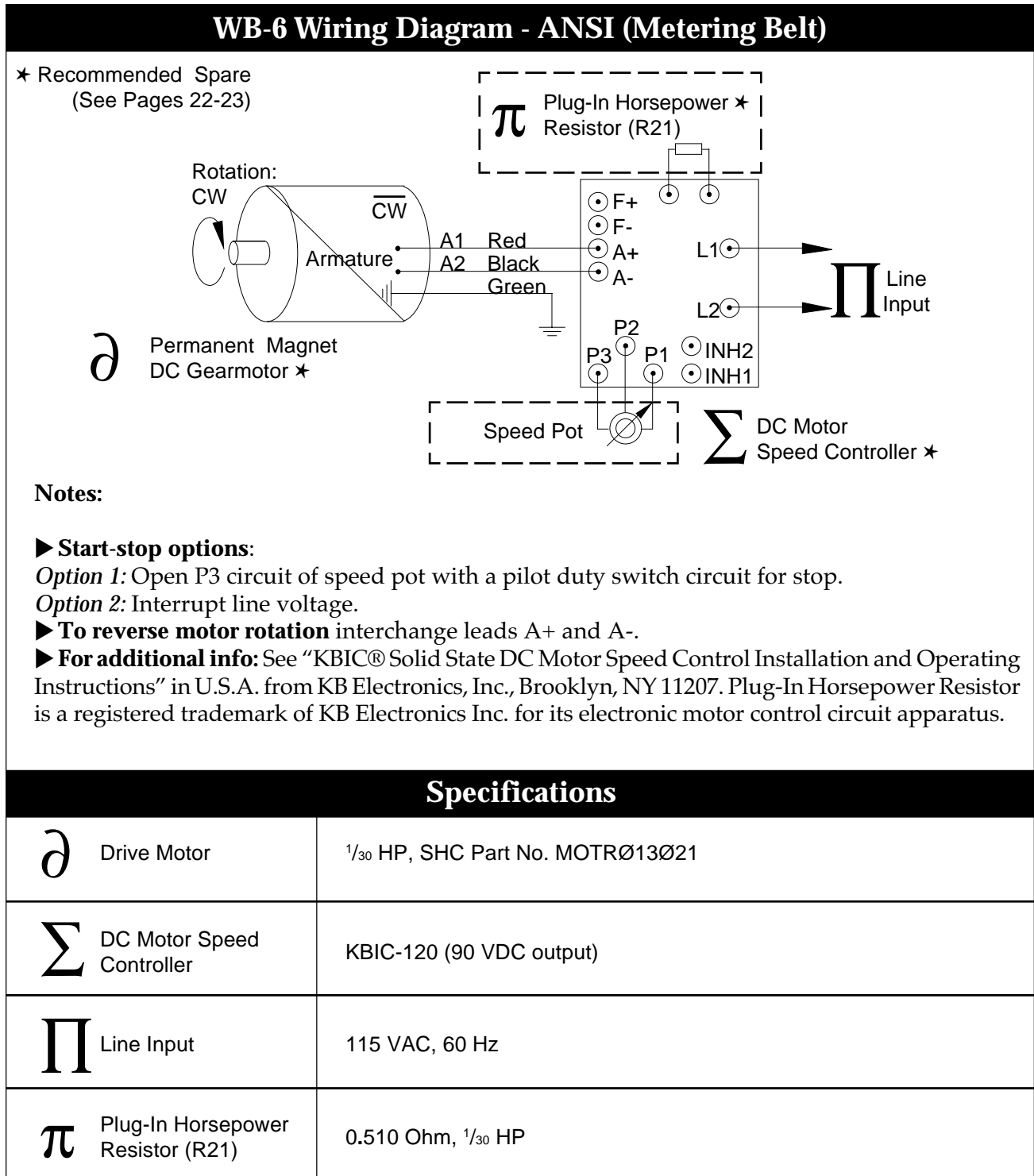

Figure 3-3. DC ANSI Suggested Wiring Diagram (Metering Belt Drive)

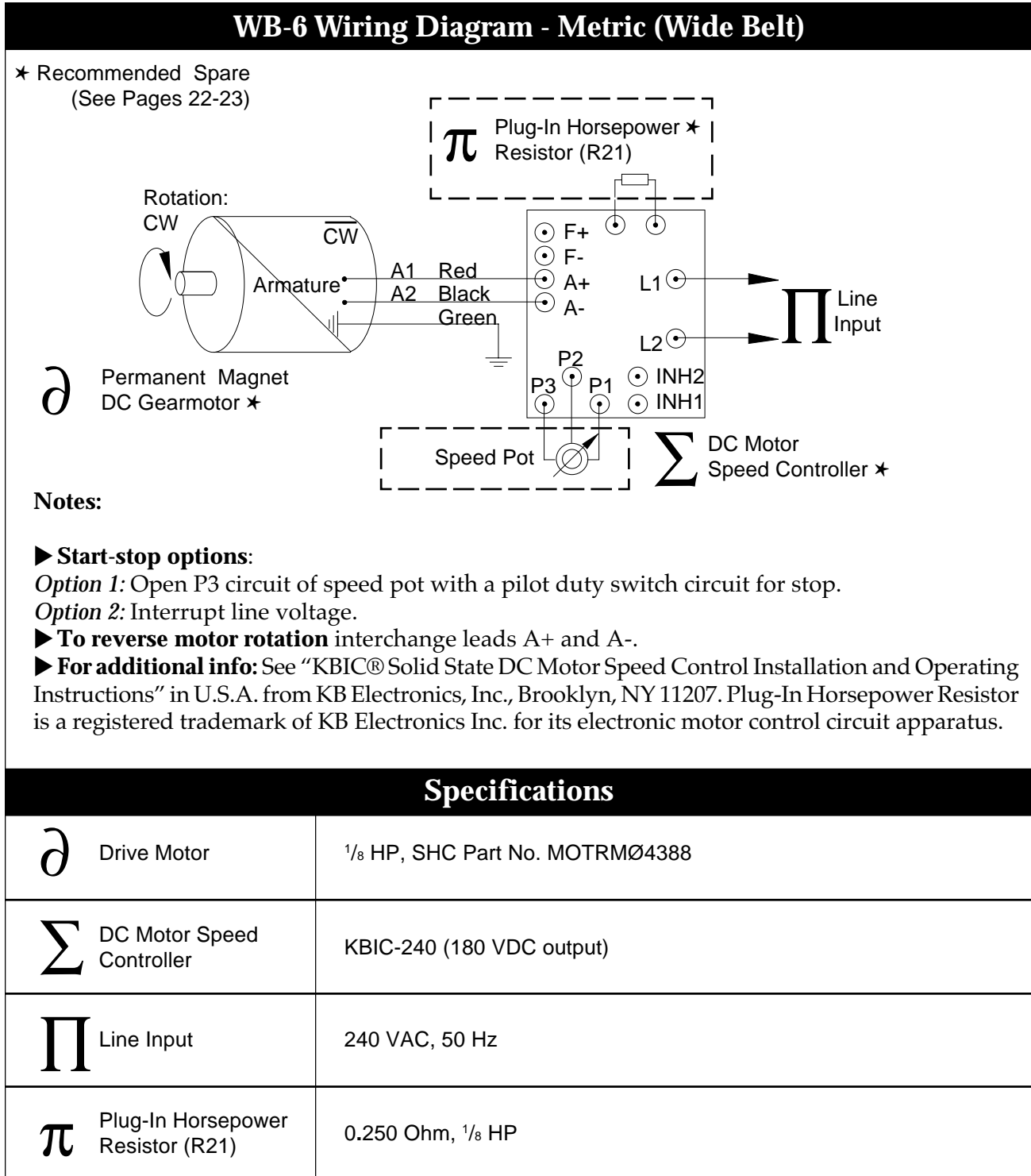

Figure 3-4. DC Metric Suggested Wiring Diagram (Wide Belt Drive)

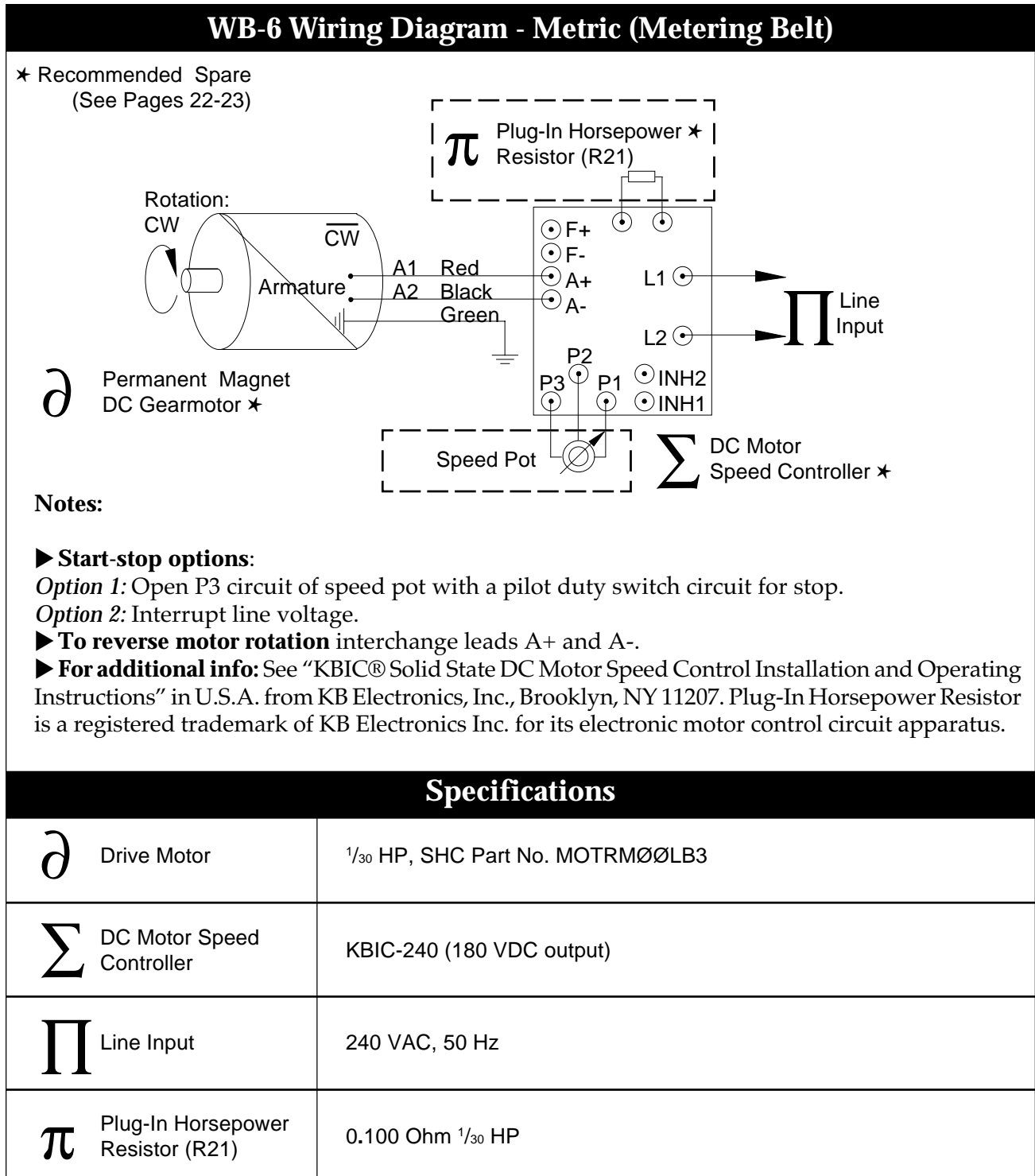

Figure 3-5. DC Metric Suggested Wiring Diagram (Metering Belt Drive)

# Repair and Maintenance

## 4

### ***Belt/Drive Assembly***

The main components of the belt/ drive assembly are a gearmotor, timing belt, a pair of pulley shafts and a drive coupling. See Figure 4-1 for part description and assembly orientation.

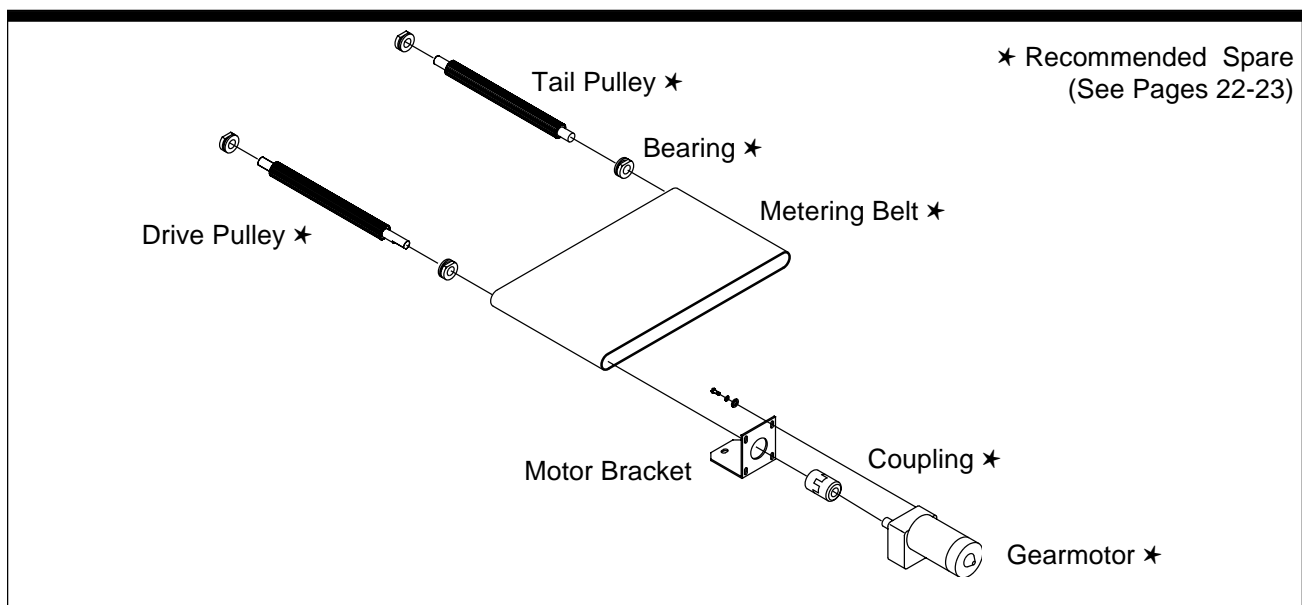

**Figure 4-1. Drive Pulley Assembly**

### ***Replacing the Metering Belt***

**Step 1—Disconnect Power.** Make sure the electrical power is turned off in a way which prevents accidental reactivation.

**Step 2—Remove Gearmotor.** First, remove the gearmotor with the wiring attached by removing the four bolts that connect the unit.

**Step 3—Remove Discharge Side Guides and Chute.** Remove the discharge side guides and discharge chute by removing the appropriate mounting screws. This will separate the discharge assembly from the belt assembly and give access to the belt.

*Continued* ►



**Step 4—Remove and Replace Belt.** Remove the metering belt assembly from the frame of the prefeeder. Remove the damaged metering belt. Place the new belt on the frame and reinstall the metering belt assembly. Make sure that the flat end of the drive pulley is aligned with the coupling and the set screw.

**Step 5—Reinstall Gearmotor.** After reassembling the prefeeder, reinstall the gearmotor.

**Step 6—Replace Discharge Side Guides and Chute.** Once the guides and chute are in the correct position, tighten any loose screws. (No tracking adjustment is necessary.) Turn on the prefeeder and check its operation.

## ***Replacing the Wide Belt***



***To avoid possible personal injury during removal and installation, have someone assist you by supporting the bed channel and other heavy parts of the prefeeder.***

**Step 1—Disconnect Power.** Make sure the electrical power is turned off in a way which prevents accidental reactivation.

**Step 2—Remove Hopper from Belt Assembly.** Remove the hopper mounting screws. This will separate the hopper from the belt assembly and give access to the belt.

**Step 3—Loosen Belt Tension.** Loosen the tensioner at the back of the belt. This will release the tension in the belt and allow the belt to move freely.

**Step 4—Remove the Drive Pulley Mounting Plates.** Remove the bolts which connect the mounting plates to the side of the prefeeder frame (side opposite the gearmotor). This will give access to the belt/drive assembly.

*Continued* ►

**Step 5—Remove Mounting Bolts from Metering Bed Assembly Mounting Support.** Remove the bolts that connect the metering bed assembly mounting support to the prefeeder frame (located on wide belt bed channel-side opposite gearmotor).

**Step 6—Detach Slider Bed.** Separate the slider bed by removing the slider bed mounting bolts. This will loosen the slider bed from the frame of the prefeeder.

**Step 7—Remove and Replace Belt.** Slide the belt over the tail and drive pulleys. Place the new belt on the frame.

**Step 8—Reassemble Prefeeder.** Reassemble the prefeeder in the reverse order of disassembly (steps 3-6). Tighten all loose screws. *Do not reinstall the hopper at this stage.*

**Step 9—Adjust Tracking.** Turn on the prefeeder and set to a slow speed to observe tracking of the belt. Run a new belt at least one minute before adjusting tracking. If the belt pulls to one side or if the belt moves from side to side, adjust the appropriate tensioner bracket necessary to correct the tracking.

***Do not overtighten the belt. When tightening the take-up pulley, apply the minimum tension necessary to take up slack and properly track the belt. If you apply too much tension you can easily destroy the belt or decrease the life of the pulley bearings and/or gearmotor.***



**Step 10—Adjust Tracking Again.** After initial tracking adjustments, run the prefeeder for at least one more minute. Continue to adjust tracking until the prefeeder runs consistently without tracking problems. Tighten or loosen the tension equally to ensure proper tension. Tighten the locknuts of the tension rod.

**Note:** *A properly tensioned belt will not slip with a hopper full of product. To avoid injury, turn off the prefeeder before checking tension.*

**Step 11—Replace Hopper.** Once the belt has the correct tension, is in the correct position and has the correct amount of tension applied, replace the hopper and tighten any loose screws.



*Ensure there is adequate clearance between the hopper and the belt. If the hopper height is not sufficient it can cause the belt to tear or become damaged.*

## ***Gearmotor Maintenance***



*Disconnect power before performing the following maintenance procedures.*

Check for wear on the gearmotor brushes by removing and inspecting each brush. If the brush is worn, replace with a new brush. Make sure to replace the brushes in the same axial position.

# Spare Parts

## 5

### ***Notice to Shibuya Hoppmann Customers***

To ensure receiving the right part, consult your system operations manual. Refer to the prefeeder's model and serial number, which was recorded on the front of this manual, when ordering replacement or service parts for your prefeeder. *This information is necessary when ordering replacement parts or service.* The system operations manual lists specific recommended spare parts.

### ***Notice to Dealer & OEM Customers***

Some components listed might have been changed by your dealer or OEM due to the specifications of your application. To ensure receiving the right part, verify the part number listed in this manual when you place your order with your dealer or OEM.

### ***In North America***

Shibuya Hoppmann Corporation  
13129 Airpark Drive, Suite 120  
Elkwood, VA 22718

**Phone:** (540) 829-2564 Toll Free: (800) 368-3582

**Fax:** (540) 829-1724

**Email:** [spares@hoppmann.com](mailto:spares@hoppmann.com)



## WB-6 Recommended Spares - ANSI

Item No.	Untooled (OEM) Part No.	Description	Page ★	Quantity	
1	MOTRØ 13Ø 21	Gearmotor - Lower Belt (Metering)	5, 13	1	1
2	MOTRØ 1Ø 875	Gearmotor - Upper Belt (Wide)	5, 12	1	1
3	CNTRKBICØ 1	Controller	12, 13	2	2
4	RESIKB.1Ø Ø	Resistor (Wide)	12	1	1
5	RESIKB.51Ø	Resistor (Metering)	13	1	1
6	LB3Ø Ø Ø 8	Delrin Bearing	17	4	4
7	BRNGINS1Ø Ø	Bearing Insert		4	4
8	FLNGBK1/25	Flange, Bearing		8	
9	FLNGNI1/25	Flange, Bearing (Nickel Plated)			8
10	BELT2482Ø 1	Wide Belt (Standard: Food Grade)	5	1	1
11	BELT352L99	Metering Belt (Standard: Black Neoprene)	5, 17	1	1
12	BELT352F99	Metering Belt (Optional: Food Grade)		1	1
13	LB3Ø 2Ø Ø	Drive Pulley (Metering Belt)	17	1	1
14	LB3Ø 3Ø Ø	Tail Pulley (Metering Belt)	17	1	1
15	PULLCONVØ 3	Drive Pulley (Wide Belt)	17	1	1
16	PULLCONVØ 5	Tail Pulley (Wide Belt)	17	1	1
17	LEVSENPKG1	Level Sensor Package	10	1	1
18	COUPHALFØ 1	Coupling Half 1"		1	1
19	COUPHALFØ 2	Coupling Half 3/4"		1	1
20	COUPHALFØ 4	Coupling Half 5/16"		1	1
21	COUPHALFØ 5	Coupling Half 5/8"		1	1
22	COUPSPIDØ 1	Coupling Spider		1	1
23	COUPSPIDØ 3	Coupling Spider		1	1

—Not available for this model    ★ —For a picture of this part, see these pages

Cold Rolled Steel    WBØ 6XXXDCA
Stainless Steel    WBØ 6XXXDSA

*Before ordering, please read the notice at the beginning of this chapter.*

**WB-6 Recommended Spares - Metric**

Item No.	Untooled (OEM) Part No.	Description	Page ★	Quantity	
1	<b>MOTRMØØLB3</b>	Gearmotor - Lower Belt (Metering)	5, 15	1	1
2	<b>MOTRMØ 4388</b>	Gearmotor - Upper Belt (Wide)	5, 14	1	1
3	<b>CNTRKBICØ 2</b>	Controller	14, 15	2	2
4	<b>RESIKB.25Ø</b>	Resistor (Wide)	14	1	1
5	<b>RESIKB.1ØØ</b>	Resistor (Metering)	15	1	1
6	<b>LB3ØØØ8</b>	Delrin Bearing	17	4	4
7	<b>BRNGINS1ØØ</b>	Bearing Insert		4	4
8	<b>FLNGBK1/25</b>	Flange, Bearing		8	
9	<b>FLNGNI1/25</b>	Flange, Bearing (Nickel Plated)			8
10	<b>BELT2482Ø 1</b>	Wide Belt (Standard: Food Grade)	5	1	1
11	<b>BELT352L99</b>	Metering Belt (Standard: Black Neoprene)	5, 17	1	1
12	<b>BELT352F99</b>	Metering Belt (Optional: Food Grade)		1	1
13	<b>LB3Ø 2ØØ</b>	Drive Pulley (Metering Belt)	17	1	1
14	<b>LB3Ø 3ØØ</b>	Tail Pulley (Metering Belt)	17	1	1
15	<b>PULLCONVØ 3</b>	Drive Pulley (Wide Belt)	17	1	1
16	<b>PULLCONVØ 5</b>	Tail Pulley (Wide Belt)	17	1	1
17	<b>LEVSENPKG1</b>	Level Sensor Package	10	1	1
18	<b>COUPHALFØ 1</b>	Coupling Half 1"		1	1
19	<b>COUPHALFØ 3</b>	Coupling Half 10mm		1	1
20	<b>COUPHALFØ 5</b>	Coupling Half 5/8"		1	1
21	<b>COUPHALFØ 8</b>	Coupling Half 19mm		1	1
22	<b>COUPSPIDØ 1</b>	Coupling Spider		1	1
23	<b>COUPSPIDØ 3</b>	Coupling Spider		1	1

—Not available for this model    ★—For a picture of this part, see these pages

<b>Cold Rolled Steel</b>	<b>WBØ 6XXXDCM</b>
<b>Stainless Steel</b>	<b>WBØ 6XXXDSM</b>

*Before ordering, please read the notice at the beginning of this chapter.*