



TP-30 Trough Prefeeder Designed for Fragile Parts Loading



Standard Features:

- All stainless steel construction
- DC variable speed motor
- Belting is FDA/USDA approved white 1-ply solid woven polyester fabric with 1/16" thick white PVC coating
- Panel mount controller card
- Mechanical style level sensor mounting kit – proximity sensor not included (P/N LEVSENPKG1)

Available Options:

- Washdown motor
- NEMA 1 encased controller
- Hopper covers
- Casters

Product Overview:

Hoppmann's standard TP-30 trough prefeeder is specially designed for handling a variety of fragile parts. The prefeeder features protective sides, food grade belt and variable speed control. Typical applications include those in which the parts may have a tendency to nest or tangle with each other, or may become damaged by a cleated belt style prefeeder.

Product Specifications:

	ANSI	Metric
A. Overall Height	63.5" ± 7.5"	1575 ± 190mm
B. Overall Width	47"	940mm
C. Overall Length	109"	2667mm
D. Dump Height (Adj.)	33.5" ± 7.5"	851 ± 190mm
E. Hopper Load Height (Adj.)	63.5" ± 7.5"	1613 ± 190mm
F. Belt Width	30"	762mm

Standard Models:

Part Number	TPXX30XDSA	TPXX30XASA
Motor Style	DC	AC
Motor Voltage	90V	230-460V
Horsepower	1/2 hp	250 W
Total Equipment Weight	450 lbs.	204 kg
Supply Hopper Capacity	30 feet ³	850 liters

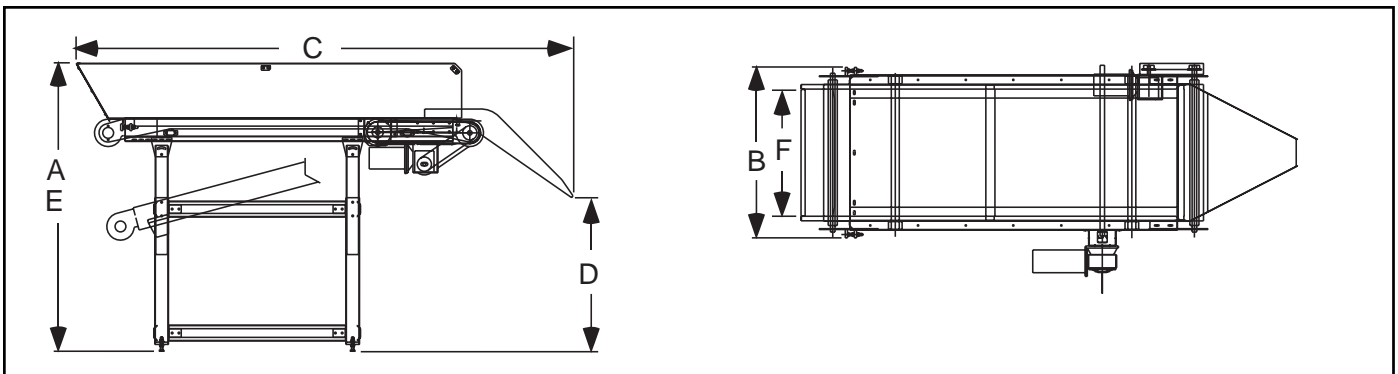

Hoppmann Corporation strives to improve its products and reserves the right to change or discontinue specifications & designs shown in this brochure without notice and without incurring obligation. 06/05

Packaging - Processing
Bid on Equipment
1-847-683-7720
www.bid-on-equipment.com

Hoppmann Corporation Headquarters
13129 Airpark Drive • Suite 120 • Elkwood, VA 22718
Tel: 540.829.2564 • 800.368.3582 • Fax: 540.829.1724
www.hoppmann.com • email: feeder@hoppmann.com

Hoppmann Corporation Manufacturing
P.O. Box 879 • 291 Dillard Rd. • Madison Heights, VA 24572
Tel: 434.929.4746 • 800.543.0915 • Fax: 434.929.4959
www.hoppmann.com • email: feeder@hoppmann.com