



Model LB-3 Prefeeder

ANSI/Metric Installation & Maintenance Manual



**Refer all servicing to
qualified personnel.**

*This manual is intended for
use by qualified mechanics
and electricians who install or
service the LB-3 Prefeeder.*

**This manual replaces the
LB-3 (ANSI and Metric) Wiring
& Spare Parts Manual and
the Prefeeder Installation &
Maintenance Manual.**

*Please copy this
information from the
LB-3 Prefeeder's
serial plate.*



Model Number:

Serial Number/Date:

Inventory Number (Check One):

- LB03XXXDCA LB03XXXDCM
- LB03XXXDSA LB03XXXDSM

First Edition, Revision 2. All Rights Reserved.

Copyright © 2006 by Shibuya Hoppmann

13129 Airpark Drive, Suite 120

Elkwood, Virginia 22718

Phone: (540) 829-2564

Toll Free: (800) 368-3582

Fax: (540) 829-1724

www.hoppmann.com • email: publications@hoppmann.com

Quick Start

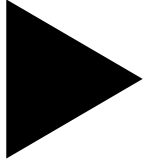

About this Manual

Assumptions

Shibuya Hoppmann assumes that all procedures contained in this manual will be performed by a qualified mechanic or electrician who must install or service the LB-3 Prefeeder. All procedures in this manual should be performed by qualified personnel or under their direction.

Models Covered

This manual covers four models. If you are unsure of your model, locate the inventory number on the serial plate of the prefeeder.

<i>Inventory No.</i>	<i>LB-3 ANSI</i>	<i>Inventory No.</i>	<i>LB-3 Metric</i>
LBØ3XXXDCA	Cold Rolled	LBØ3XXXDCM....	Cold Rolled
LBØ3XXXDSA	Stainless	LBØ3XXXDSM ...	Stainless

Caution Symbols and Messages

Caution symbols and messages in this manual call attention to hazardous voltages, moving parts and other hazardous conditions.



The exclamation point caution symbol denotes possible personal injury and/or damage to the equipment.



The lightning bolt caution symbol denotes possible personal injury and/or damage to the equipment from electrical hazards.

Before You Start

Tools You Will Need

The LB-3 elevating prefeeder is offered in both ANSI and metric versions. For maximum compatibility, ANSI units are classified as “soft ANSI” construction, meaning that metric threads and hardware are used throughout. Both metric and ANSI units require metric tools for repair or adjustment.

Equipment Improvements & Document Revisions Notice

Shibuya Hoppmann continually improves its products and reserves the right to change or discontinue specifications and designs shown in this manual without notice and without incurring obligation. Shibuya Hoppmann has made every effort to verify the information contained in this manual, but reserves the right to correct any error at the time of the manual’s next revision. This manual is subject to change without notice.

3/06

Table of Contents

	Page	Chapter
Quick Start	2	About this Manual
	2	Before You Start
Prefeeder Description & Specifications	5	The LB-3 Prefeeder: An Overview
		<i>Figures</i>
	5	Figure 1-1. LB-3 Overhead Prefeeder
	6	Figure 1-2. LB-3 Prefeeder Specifications
Safety Precautions	7	Warnings
	7	Operating & Maintenance: Do's & Don'ts
Installation & Startup	9	If the Prefeeder is Already Set Up
	9	Unpacking and Inspection
	9	Physical Setup
	10	Installing Hopper Extensions
	11	Controlling the Level Sensor
	11	Establishing the Correct Prefeeder Speed
		<i>Figures</i>
	10	Figure 3-1. Hopper Extension
11	Figure 3-2. Level Sensor Mount Package	
12	Figure 3-2. DC ANSI Suggested Wiring Diagram	
13	Figure 3-3. Metric Suggested Wiring Diagram	

	Page		Chapter
Repair & Maintenance	15	Drive Assembly	4
	15	Replacing the Belt	
	16	Gearmotor Maintenance	
	16	General Cleaning	
		<i>Figures</i>	
	14	Figure 4-1. Drive Pulley Assembly	
Spare Parts	17	Notice to Shibuya Hoppmann Customers	5
	17	Notice to Dealer & OEM Customers	
	17	In North America	
	18	Spares	
	19	Warranty	
	20	Scheduled Preventive Maintenance Log	

Prefeeder Description & Specifications

1

The LB-3 Prefeeder: An Overview

Function The LB-3 overhead prefeeder is designed to load small to medium parts and are engineered to interface directly with smaller style feeders. The "3" refers to the supply hoppers capacity of 3 cubic feet. See Figure 1-1 for a diagram of the LB-3 Prefeeder and Figure 1-2 for the LB-3 Prefeeder Specifications.

Operation of Equipment Product is loaded into a supply hopper. The product then passes through the gate which meters the flow of parts from the prefeeder. Product is then metered into either the recipient feeder bowl or other equipment.

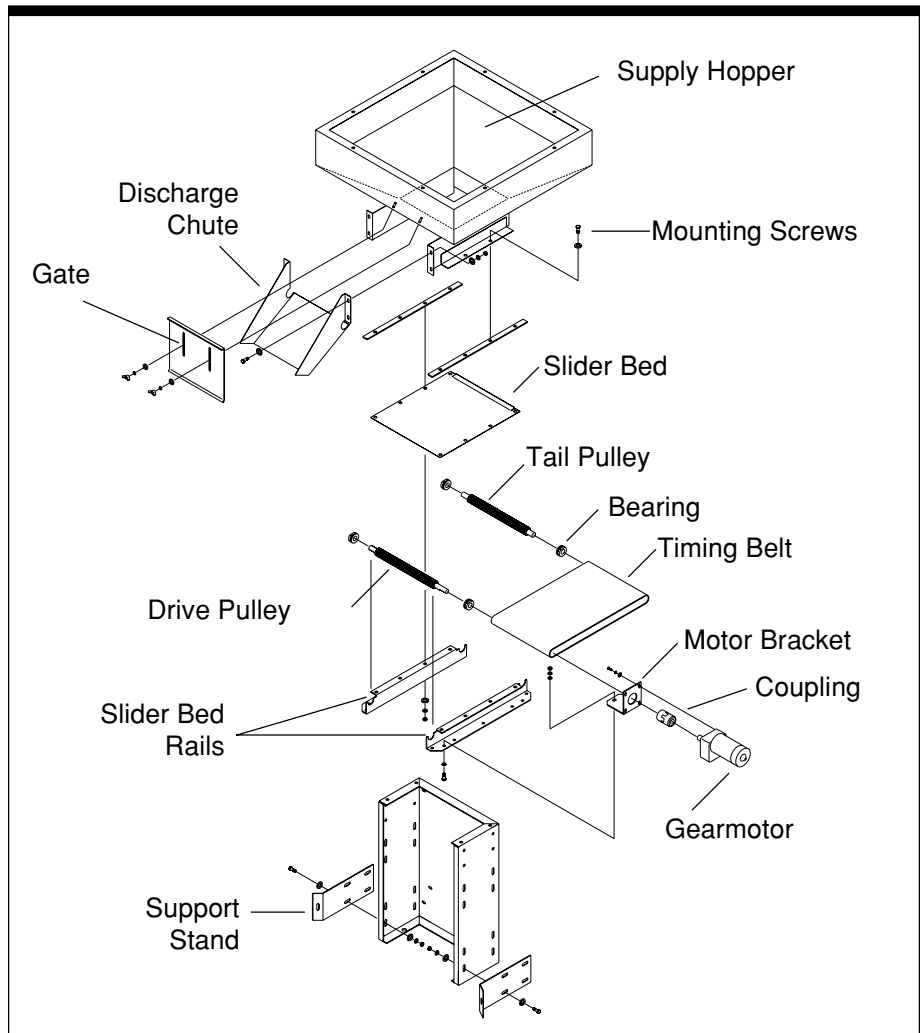

Figure 1-1. LB-3 Overhead Prefeeder (DC Drive)

Product Specifications

ANSI

Metric

Drive Motor Size	1/30 HP	27 W
Supply Voltage	115 VAC	220 VAC
Drive Motor Voltage	90 VDC	180 VDC
Power Usage	0.33 amps	0.20 amps
Weight	110 lbs	50 kg
Hopper Capacity	3 ft ³	85 liters

A. Hopper Width and Length	24"	610 mm
B. Prefeeder Height	16.5"	419 mm
C. Prefeeder Height (w/ stand)	37"	940 mm
D. Discharge Height	17.5"	445 mm
E. Belt Width	9.9"	252 mm

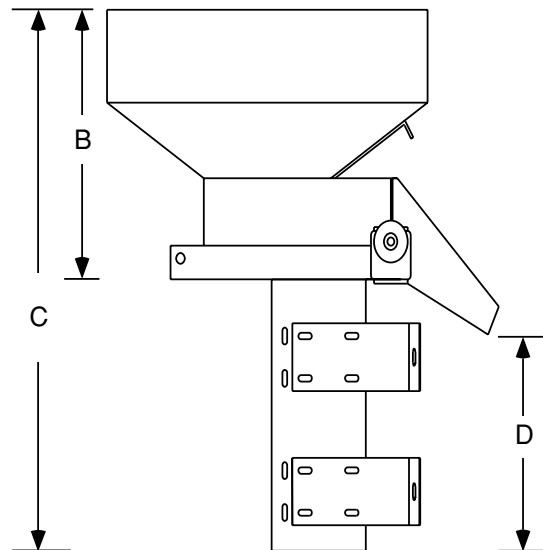
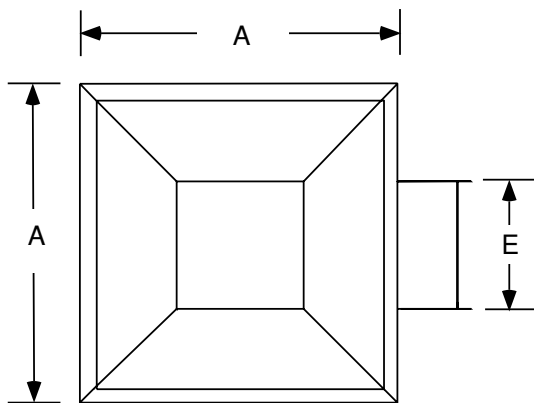

Your direct supplier may have changed some of these specifications during tooling to better match your application's requirements.

Figure 1-2. LB-3 Prefeeder Specifications

Safety Precautions

2

Warnings



Turn Off Power! Before servicing, make sure you have turned off compressed air and electrical power in a way which prevents accidental reactivation. Padlock and clearly tag the appropriate electrical and pneumatic disconnects. Lockout/tagout procedures are covered in United States Code of Federal Regulation (CFR) Title 29 Part 1910.147, "The Control of Hazardous Energy."



Dress Appropriately! Reduce the risk of injury from moving parts by securing loose sleeves and other clothing. Do not wear loose jewelry or neckties near the prefeeder. Wear safety glasses or other protective eyewear when servicing or operating the prefeeder. Never place hands or tools in the prefeeder when it is operating.



Install Safety Covers! Make sure the prefeeder remains safe to operate. Be sure all safety covers have all been installed before returning the prefeeder to normal operation. Safety covers on the prefeeder include any covers installed by your direct supplier as well as standard permanent guarding.

Operating & Maintenance: Do's & Don'ts

Don't Install the Prefeeder Near Flammable Gas, Vapor or Dust. You must install additional approved explosion-proof or dust ignition-proof enclosures if installation occurs under these conditions. Without such additional enclosures, normal sparking of the brushes inside the motor could ignite flammable gas, vapor or dust.

Do Use the Same or Identical Mounting Screws if Replacing the Motor. If longer mounting screws are used, they may come into contact with parts of the motor that conduct electricity.

Installation & Startup

3

If the Prefeeder is Already Set Up

If you bought a Shibuya Hoppmann prefeeder as part of a Hoppmann feeder system, then your direct supplier will have performed all the procedures in this chapter. You will still need to:

- ▶ **Position your Prefeeder.** Follow the equipment layout drawing provided by your direct supplier.
- ▶ **Connect Electrical Wiring.** Follow as-built electrical diagrams provided by your direct supplier.
- ▶ **Install and Test the Rest of the System.** Installation is complete.

Note: *If the Shibuya Hoppmann prefeeder is drop-shipped to your location, follow the procedures in this chapter to finish setting up the prefeeder.*

Unpacking and Inspection

Step 1—Inspect and Unpack the Crate. Remove packing materials from sensors, tooling and moving parts. Make a visual check to be sure parts have not come loose during shipping. If you find any concealed damage, call the shipping carrier and your direct supplier immediately. ***Do not attempt to fix the problem yourself unless told to do so by your direct supplier.***



Step 2—Record Serial Number of Prefeeder. If you have not already done so, record the prefeeder's model and serial number on the front of this manual. *This information is helpful when ordering replacement parts or service.*

Physical Setup

Step 1—Position the Feeder. Place the feeder as shown on the equipment layout drawing provided by your direct supplier.

Continued ▶

Step 2—Position the Prefeeder. If you are using a Shibuya Hoppmann Centrifugal Feeder, position the prefeeder so discharged product falls, into the reservoir area, opposite from where product loads onto the rim (refer to Shibuya Hoppmann Centrifugal Feeder manual). Avoid positioning the prefeeder in a way that allows product to bounce onto the rim of the bowl—disturbing already oriented parts. If you are not using a Shibuya Hoppmann Centrifugal Feeder, follow the equipment layout drawing provided by your direct supplier.

Step 3—Connect Power and Air. Connect the prefeeder to power and compressed air (if applicable). Do not change the prefeeder's main air regulator; it should already be correct when you receive the prefeeder.

Installing Hopper Extensions

When installing hopper extensions, see Figure 3-1 to position the extensions correctly. Use the hardware provided for installation.

Note: Figure does not necessarily show all mounting hardware.

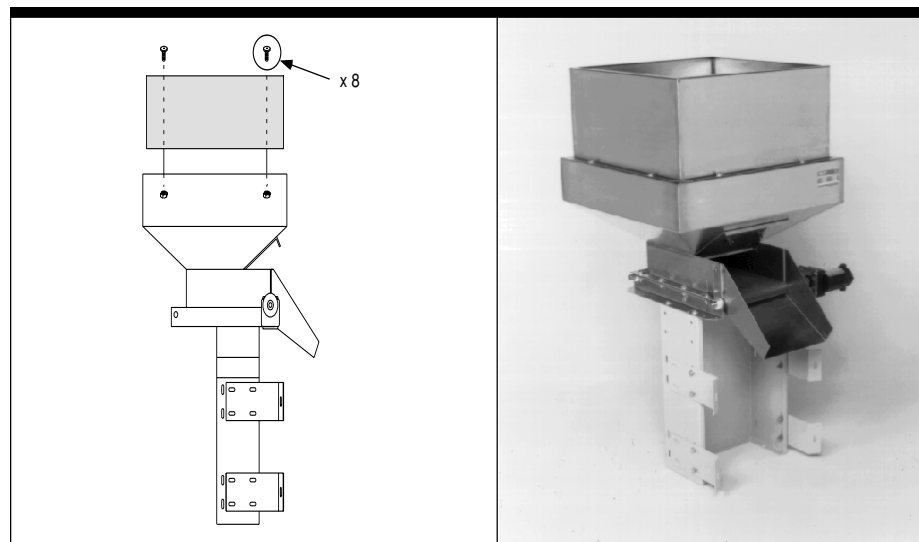

Figure 3-1.
Hopper Extension

Level Sensor

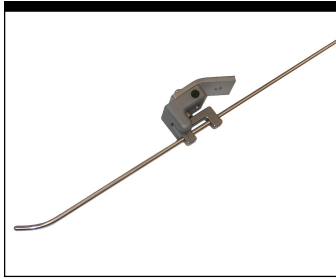

Figure 3-2. Level Sensor Mount Package

The prefeeder is usually controlled by a level sensor mounted in the centrifugal feeder or other equipment. The sensor keeps the level of product, from the prefeeder to the equipment, relatively constant by controlling the amount of product metered into the receiving equipment. The level sensor mount package has been provided with your prefeeder; however, the package does not include a proximity sensor (see Figure 3-2). The proper proximity sensor is a standard 8 mm diameter threaded sensor (choice of sensor dependent on electrical system specifications). For further information contact Hoppmann Corporation or your direct supplier.

Establishing the Correct Prefeeder Speed

To establish the correct prefeeder speed, turn the prefeeder's speed control to $\frac{1}{4}$ its maximum setting. Once product begins to exit the centrifugal feeder or other equipment, determine the output of your prefeeder. To obtain a valid rate, count product for at least one minute.

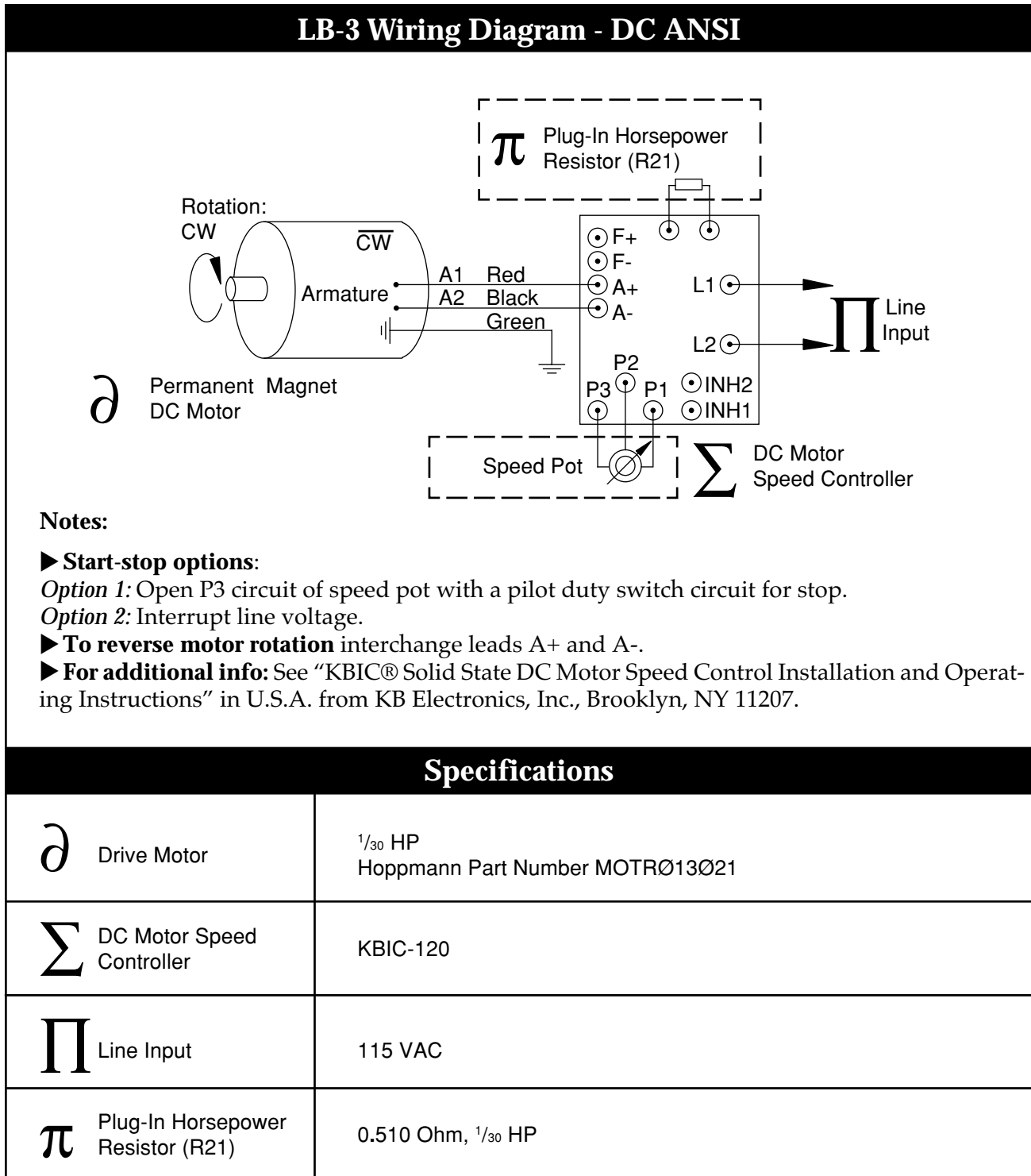

Figure 3-3. DC ANSI Suggested Wiring Diagram

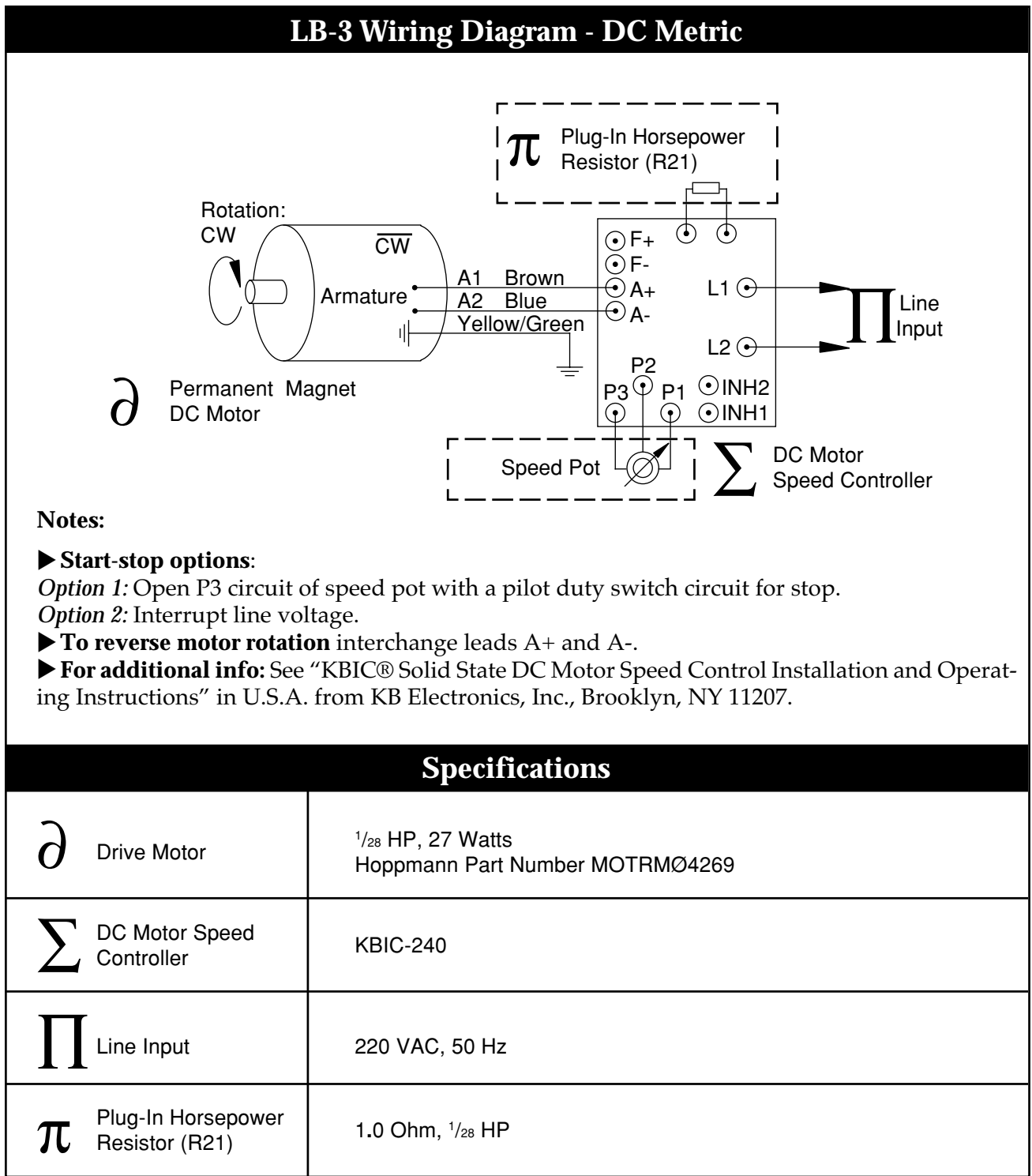

Figure 3-4. Metric Suggested Wiring Diagram

Repair and Maintenance

4

Belt/Drive Assembly

The main components of the belt/ drive assembly are a gearmotor, timing belt, a pair of pulley shafts and a drive coupling. See Figure 4-1 for part description and assembly orientation.

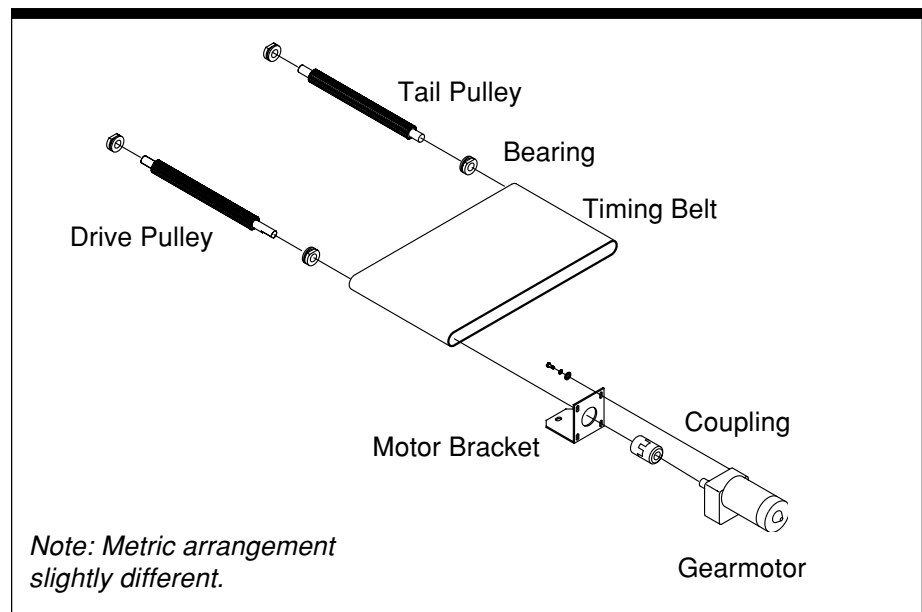

Figure 4-1.
Belt/Drive Assembly

Replacing the Belt

Step 1—Disconnect Power. Make sure the electrical power is turned off in a way which prevents accidental reactivation.

Step 2—Remove Gearmotor. First, remove the gearmotor with the wiring attached by removing the four bolts that connect the unit.

Step 3—Detach Belt Assembly From Stand. Remove the prefeeder from the equipment by separating the belt assembly and the hopper from the stand.

Note: It is not necessary to remove the stand from the equipment.

Continued ►

Step 4—Remove Hopper from Belt Assembly. Once the prefeeder has been disconnected from the equipment, remove the hopper mounting screws. This will separate the hopper from the belt assembly and give access to the belt.

Step 5—Remove and Replace Belt. Remove the old belt from the frame of the prefeeder. Place the new belt on the frame. Make sure that the flat end of the drive pulley is aligned with the coupling and the set screw.

Step 6—Replace Hopper. Once the belt is in the correct position, tighten any loose screws. (No tracking adjustment is necessary.) Replace the hopper and secure it to the prefeeder.

Step 7—Remount the Prefeeder. After the prefeeder is reassembled, remount the prefeeder to the equipment.

Step 8—Reinstall Gearmotor. After mounting the prefeeder, reinstall the gearmotor and check the operation of the prefeeder .

Gearmotor Maintenance



Disconnect power before performing the following maintenance procedures.

Check for wear on the gearmotor brushes by removing and inspecting each brush. If the brush is worn, replace with a new brush. Make sure to replace the brushes in the same axial position.

Note: Prefeeder are equipped with acetal plastic bearings which do not require any maintenance and should not be lubricated.

General Cleaning

When necessary, clean the belt surface with a cloth dampened with water or use a mild household cleaner. Wipe damp surfaces with a dry, clean cloth.

Spare Parts

5

Notice to Shibuya Hoppmann Customers

To ensure receiving the right part, consult your system operations manual. Refer to the prefeeder's model and serial number, which was recorded on the front of this manual, when ordering replacement or service parts for your prefeeder. *This information is necessary when ordering replacement parts or service.* The system operations manual lists specific recommended spare parts.

Notice to Dealer & OEM Customers

Some components listed might have been changed by your dealer or OEM to work better with your application. To ensure receiving the right part, verify the part number listed in this manual when you place your order with your dealer or OEM.

In North America

Shibuya Hoppmann
13129 Airpark Drive, Suite 120
Elkwood, VA 22718USA
Phone: (540) 829-2564 Toll Free: (800) 368-3582
Fax: (540) 29-1724
e-mail: spares@hoppmann.com
website: www.hoppmann.com

LB-03 Critical Spares - ANSI

Part Number	Description	Page *	Critical Quantity	
MOTR013021	Motor, 1/30 hp	5, 12, 13, 15		1
CNTRKBIC01	Motor Controller, 90VDC	12		1
RESIKB.035	Resistor, 0.035 OHM	12, 13		1
MOTRAC12HP	Motor, .12 hp, 208-230/460		1	
NMRV300080	Speed Reducer, 80:1		1	
NMRV30MSHF	Single Output Shaft		1	

LB03 Recommended Spares - ANSI

Part Number	Description	Page *	Quantity	
LB30008	Bearing	5, 15	4	4
COUPHALF04	Coupling Half, 5/16" B L050	5, 15		1
COUPHALF05	Coupling Half, 5/8" B L050	5, 15	1	1
COUPSPID01	Coupling Spider L050	5, 15	1	1
LB30303	Coupling Modification	5, 15	1	
BELT352L99	Standard Belt - Black Neoprene Fiberglass Cord	5, 15	◆	◆
BELT325F99	Food Grade Belt - FDA Tan Neoprene Belt	5, 15	◆	◆
HX03LB03SU	Hopper Extension	10	1	1

—Not available with this model
 * —For a picture of this part, see these pages

◆ Determine your model is food grade or standard for the appropriate belt replacement.

Stainless Steel - AC Motor LB03XXXASA

Stainless Steel - DC Motor LB03XXXDSA