



LB-03/06 Live Bottom Prefeeder

Designed for Overhead Parts Loading



Product Overview:

Hoppmann's standard LB-03 and LB-06 overhead prefeeders are designed to handle small to medium sized parts and are engineered to interface directly with smaller style parts feeders. A variable speed motor drives the belt at a speed of 23.00 inches per minute.

Product Specifications:

	ANSI	Metric
A. Hopper Width & Length	24" x 24"	610mm x 610mm
B. Overall Height - LB-03	37"	940mm
Overall Height - LB-06	47.5"	1207mm
C. Discharge Height	17.5"	445mm
D. Belt Width	9.9"	252mm

Standard Models:

Part Number	LB03XXXDSA
Motor Style	DC
Motor Voltage	90V
Horsepower	1/30 hp/25 W
Total Equipment Weight	110 lbs./50 kg
Hopper Capacity (LB-3)	3 ft ³ /85 liters
Hopper Capacity (LB-6)	6 ft ³ /170 liters

Standard Features:

- All stainless steel construction
- Durable reinforced black neoprene belt with fiberglass cord
- Adjustable mounting brackets
- Panel mount controller card
- Mechanical style level sensor mounting kit – proximity sensor not included (P/N LEVSENPKG1)

Available Options:

- Continuous welded seams
- Hopper covers
- Tan neoprene USDA/FDA dry contact food belt with fiberglass cord
- NEMA 1 encased controller

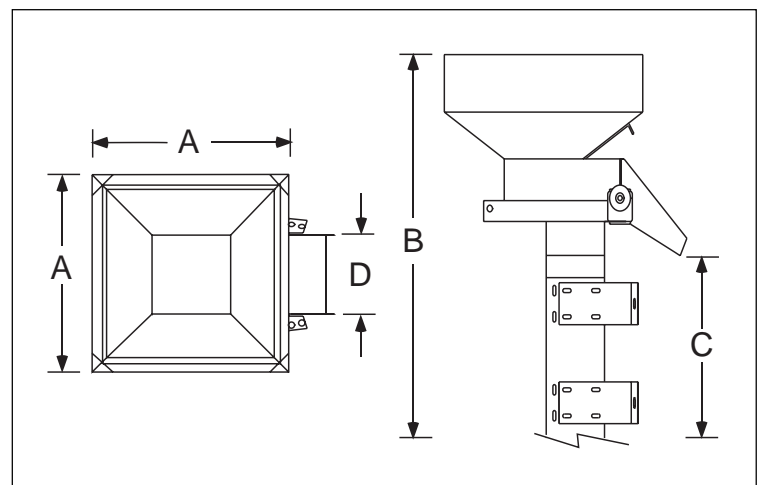

Hoppmann Corporation strives to improve its products and reserves the right to change or discontinue specifications & designs shown in this brochure without notice and without incurring obligation. 06/05