

## L500A V2 High Speed Label Applicator

### Pressure Sensitive Label Head

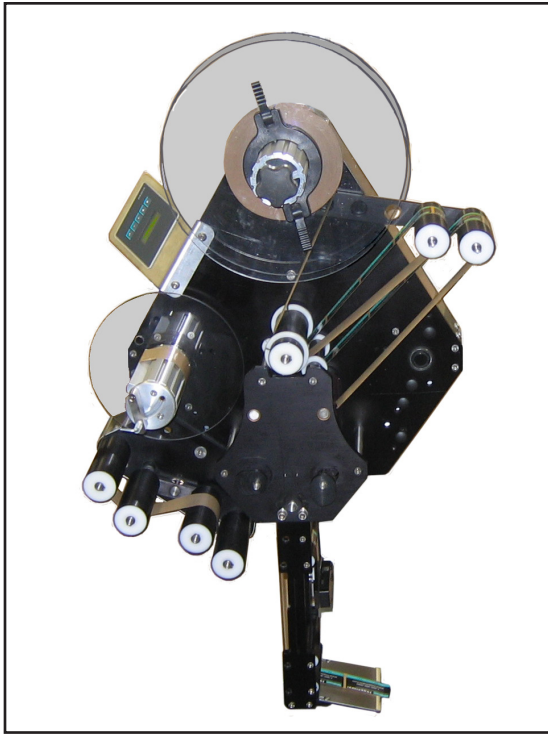

#### Product Overview:

Shibuya Hoppmann's new L500A V2 High Speed pressure sensitive label head is designed to meet the needs of stand-alone applications, or the integration of multiple label heads into high speed product handling systems. The L500A V2 HS label applicators are ergonomically designed to provide user friendly, seamless solutions for today's most demanding labeling applications.

The unprecedented convertibility of the L500A V2 HS chassis allows the label head to be converted from right-hand to left-hand justified, or vice versa, in a matter of minutes.

#### Standard Label Applicator Specifications:

Labeling Rate (ppm).....	Up to 800 ppm *
Label Head Speed.....	3,500"/min (1482mm/sec)
Accuracy.....	± 0.02" (0.5mm)
Controls.....	Dual Processor
Label Drive Motor.....	High Torque Micro Stepper (12Nm)
Unwind Roll Diameter.....	14" (356mm) OD x 3" (76mm) ID
Label Detection.....	Capitance
Machine Interface.....	External Sub D Connectors
Power Requirements.....	115/220 VAC, 60 Hz, 6 Amps
Environment.....	41-104°F (5-10°C), 25-85% Relative Humidity)

#### Standard Features:

- On board diagnostics
- 3,500"/min (1482mm/sec) label head speed
- High torque stepper motor
- Placement accuracy of +/- 0.02" (0.5mm)
- Advance through missing labels
- Product Recipes
- 14" (355mm) diameter unwind roll standard
- On-the-fly web adjustments
- No tools required for roll changeover
- Label head applicator widths in 4, 6 and 8 inches (102mm, 152mm and 203mm)
- Dual nip roller for less web breakage
- Coding/Inspection accommodation
- Streamline footprint
- Assortment of modules including Tamp-Blow
- Ambidextrous right-hand and left-hand

\* Dependent upon label and application

#### Available Options and Upgrades:

- Tamp-On, Blow-On & Tamp-Blow modules
- Wash down head
- Harsh environment head
- Line encoder kit upgrades
- Peeler plate adjustable brush or squeeze kit
- Label low level sensor and beacon fault upgrades
- Adjustable "T" stands and machine mount supports

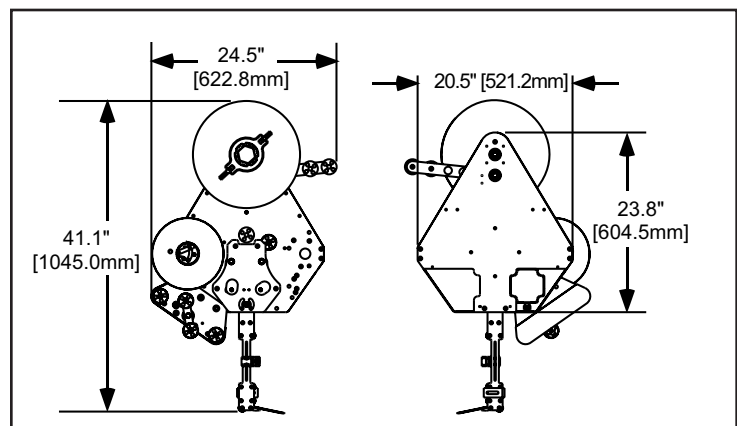

Shibuya Hoppmann Corporation strives to improve its products and reserves the right to change or discontinue specifications & designs shown in this brochure without notice and without incurring obligation. 02/08