



## FRS-70 Centrifugal Feeder

*Designed for Quiet, High Speed Feeding*



**Product Overview:**

Hoppmann's FRS-70 is specifically designed to feed a wide range of large bottles and parts. The delivery rate varies from moderate to high speed depending on part characteristics. The FRS-70 is engineered to interface with Hoppmann prefeeders, accumulating conveyors, assembly systems and other downstream equipment.

**Product Specifications:**

|                               | <u>ANSI</u> | <u>Metric</u> |
|-------------------------------|-------------|---------------|
| A. Overall Width at Exit Zone | 108"        | 2743mm        |
| B. Overall Width              | 108"        | 2743mm        |
| C. Overall Height             | 85" ± 3"    | 2159mm ± 76mm |
| D. Discharge Height           | 53" ± 3"    | 1386mm ± 76mm |
| E. Bowl Inside Diameter       | 66"         | 1676mm        |
| F. Rim Width                  | 6.7"        | 169mm         |
| G. Scallop Length             | 15"         | 381mm         |

**Standard Models:**

| Part Number     | <u>RS70XXXDSA</u> | <u>RS70XXXASA</u> |
|-----------------|-------------------|-------------------|
| Motor Style     | DC                | AC                |
| Motor Voltage   | 90V               | 208-230/480V      |
| Horsepower      | 1 hp              | 746W              |
| Weight Untooled | 3500 lbs          | 1587 kg           |

**Standard Features:**

- Aluminum bowl with stainless steel walls
- Hinged polycarbonated cover with safety interlocks
- Air clutch
- Backup ring
- Panel mount controller card

**Available Options:**

- Washdown motor
- Urethane scallop kit
- NEMA 1 encased controller

**Required Accessories:**

FRS Series Scallop Kit ..... URTHCAST64

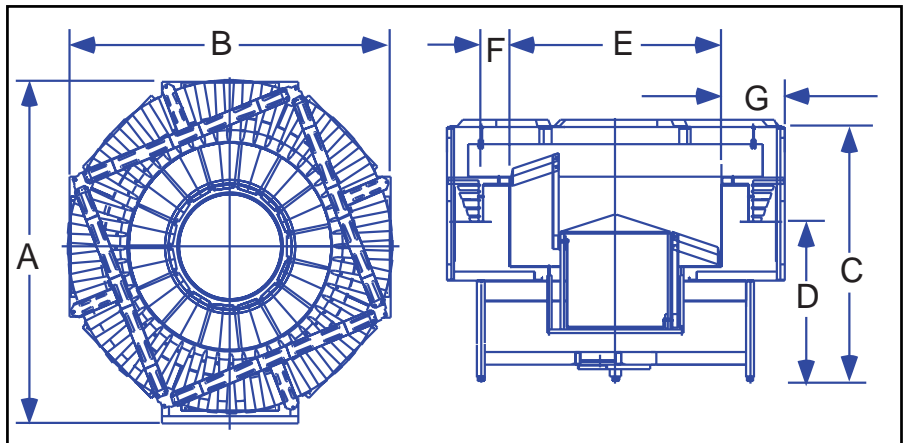

Hoppmann Corporation strives to improve its products and reserves the right to change or discontinue specifications & designs shown in this brochure without notice and without incurring obligation. 06/05

**Packaging - Processing**  
**Bid on Equipment**  
 1-847-683-7720  
[www.bid-on-equipment.com](http://www.bid-on-equipment.com)

**Hoppmann Corporation Headquarters**  
 13129 Airpark Drive • Suite 120 • Elkwood, VA 22718  
 Tel: 540.829.2564 • 800.368.3582 • Fax: 540.829.1724  
[www.hoppmann.com](http://www.hoppmann.com) • email: [feeder@hoppmann.com](mailto:feeder@hoppmann.com)

**Hoppmann Corporation Manufacturing**  
 P.O. Box 879 • 291 Dillard Rd. • Madison Heights, VA 24572  
 Tel: 434.929.4746 • 800.543.0915 • Fax: 434.929.4959  
[www.hoppmann.com](http://www.hoppmann.com) • email: [feeder@hoppmann.com](mailto:feeder@hoppmann.com)