

EP-35/18, EP-50/18

Product Overview

Hoppmann's EP-35/18 and EP-50/18 elevating prefeeders are designed to handle large parts. A heavy duty variable speed motor and standard bowl level sensor ensure proper product metering. Designed for floor level parts loading and hopper cleanout.



Product Specifications

	U.S.	Global
A. Overall Width	72"	1829mm
B. Hopper Length	61"	1549mm
C. Overall Length	95"	2413mm
D. Overall Height	85" ± 1"	2159mm ± 25mm
E. Dump Height (Adjustable)	45" - 58"	1143mm-1473mm
F. Belt Width	18"	457mm
G. Hopper Load Height (EP-35/18)	45"	1143mm
Hopper Load Height (EP-50/18)	51"	1295mm
Motor Size	1/2 HP	373W
Motor Frame Size	NEMA 56C	IEC 71D
Supply Voltage	115 VAC	240 VAC
Motor Voltage	90 VDC	240 VAC 3PH
Power Usage	6 amps	3 amps
Weight	1200 lbs	544kg
Hopper Capacity (EP-35/18)	35 ft ³	990 liters

Standard Features

- Stainless steel construction
- Adjustable elevation angle
- Adjustable discharge height
- Hopper clean out door with adjustable chute
- FDA/USDA approved belt material

Standard Options

- Agitator
- Dust covers
- Discharge height extension kits
- 180 VDC variable speed motor (metric only)

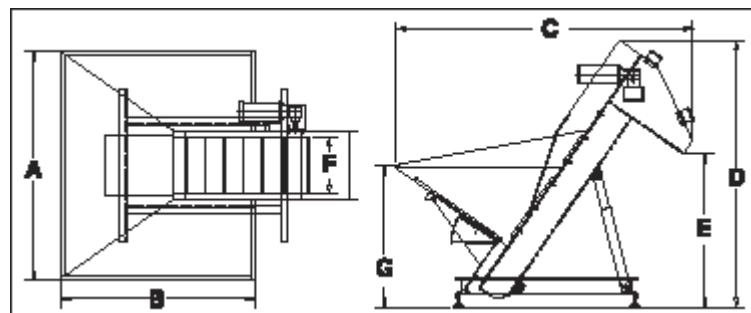

Hoppmann Corporation continually strives to improve its products. Therefore, Hoppmann reserves the right to change or discontinue specifications and designs shown in this brochure without notice and without incurring obligation. 1/98