



EH-08/EH-15/EH-25 Horizontal Discharge Elevating Prefeeder Designed for Floor Level Parts Loading



The horizontal discharge head allows for the prefeeder's discharge location to move horizontally, creating smaller drop heights between the prefeeder and the feeder.



Product Overview:

Hoppmann's standard EH-08 elevating prefeeder is designed to handle a variety of medium sized parts. Using a modular, plastic, cleated chain to vertically and horizontally transport parts, the EH-08's multi-dimensional discharge is closer to the feeder bowl, eliminates potential scraping or scuffing of parts, and is able to reach over existing equipment via the horizontal discharge chute. Its eight (8) cubic foot capacity hopper delivers product at an average belt speed of 32 feet per minute. The cleated elevator belt has a nominal cleat height of 2.00" and a cleat pitch of 6.00" allowing for maximum product loading. A heavy duty variable speed motor helps to ensure proper product metering.

Product Specifications:

	ANSI	Metric
A. Overall Width	42"	1067mm
B. Frame & Hopper Length	63"	1600mm
C. Modular Chain Width	9"	229mm
D. Hopper Load Height - EH-08	≈ 34"	864mm
Hopper Load Height - EH-15	≈ 41"	1041mm
Hopper Load Height - EH-25	≈ 50"	1270mm
E. Discharge Height (Adjustable)	49" - 79"	1676 - 2515mm
F. Overall Height (Adjustable)	65" - 95"	2083 - 2921mm

Standard Models:

Part Number	EH0808XDSA	EH0808XASA
Motor Style	DC	AC
Motor Voltage	230V	230V
Horsepower	1/4 hp	186 W
Total Equipment Weight	1000 lbs.	454 kg
Hopper Capacity (EH-8)	8 ft ³	227 liters
Hopper Capacity (EH-15)	15 ft ³	425 liters
Hopper Capacity (EH-25)	25 ft ³	708 liters

Standard Features:

- All stainless steel construction
- Modular plastic chain
- Hopper cleanout door
- One piece formed hopper (EH-08)
- Panel mount controller card
- Mechanical style level sensor mounting kit – proximity sensor not included (P/N LEVSENPKG1)

Available Options:

- Elevator extensions*
- Hopper extension for 15 and 25 ft³ capacity
- Continuous welded hopper seams (EH-15/EH-25)
- Elevator/hopper covers
- Washdown motor
- NEMA 1 encased controller
- Pneumatic hopper agitator (P/N AGITATOREP08)
- Casters

*It is strongly recommended that the frame of the prefeeder be reinforced and/or additionally supported for elevator extensions of 54" or greater.

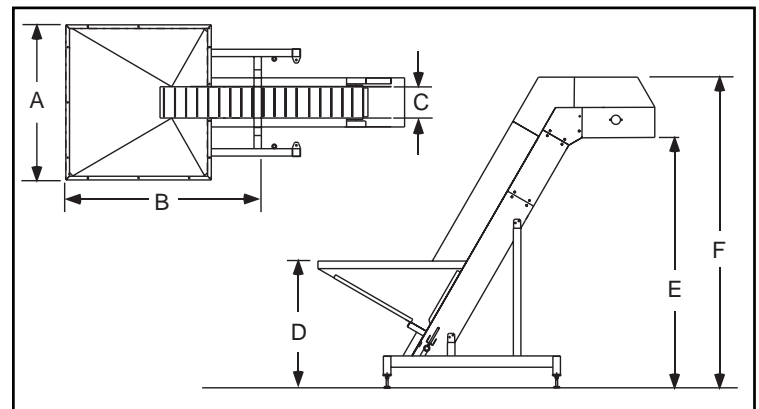

Hoppmann Corporation strives to improve its products and reserves the right to change or discontinue specifications & designs shown in this brochure without notice and without incurring obligation. 06/05