

HOBART701 S Ridge Avenue, Troy, OH 45374
1-888-4HOBART • www.hobartcorp.com**SL100
SERVICE SCALE****HOBART****STANDARD FEATURES**

- Customer ready file load includes 4 custom label formats and 1 custom safe handling logo
- Backlit LCD displays
- PLU, Group, and Operator Totals (printed on label stock)
- Weighing capability - 30 Lb x 0.01
- Barcode types - EAN, UPC
- Cost saving "rewind" printer
- 250 character expanded text
- 40 character product description

MODEL

- SL100 – Service Scale

Specifications, Details and Dimensions on Inside and Back.

**SL100 FEATURES****Weigh Types**

- Wait on customer
- Production entry
- Prepackaged products

Data Memory

- Up to 1,000 PLUs
- One custom logo

Programmability

- Manual entry with keypad or with LX20 software via RS232 serial communication from a computer

Backup

- Via RS232 serial communications from a computer

Communications

- RS485 serial interface between scales

Operators Console

- 57 key keyboard, 34 direct PLUs, audible beep, envelope pocket for custom overlays, wipe clean design
- Up to 8 operators from the same network

Networking

- Up to 9 scales

**SL100 SERVICE SCALE**

SL100 SERVICE SCALE



701 S Ridge Avenue, Troy, OH 45374
1-888-4HOBART • www.hobartcorp.com

LABEL EXAMPLES

PORTRAIT FORMAT

- 2.25" x 1.75"
- 2.25" x 2.375"
- 2.25" x 3.00"
- 2.25" x Continuous

Other die cut lengths (between 1.57" x 6.3") can be custom ordered – contact your label supplier for price quote

LANDSCAPE FORMAT

Contact your sales rep for more information

Barcode: < 200010 010420 >

Main market
From us to you!

DESCRIPTION DESCRIPTION
DESCRIPTION

Packed On: 08-28-08 Sell By: 08-31-08

Net Wt/Ct: 1.74 lb Unit Price: \$ 5.99 Total Price: \$ 10.42

HOBART CORPORATION
TROY, OH 45374

FORMAT 0, 1.75"L

Barcode: < 200020 010427 >

Main market
From us to you!

DESCRIPTION DESCRIPTION
DESCRIPTION

INGREDIENTS

KEEP REFRIGERATED Sell By: 08-31-08

Net Wt/Ct: 1.74 lb Unit Price: \$ 5.99 Total Price: \$ 10.42

HOBART CORPORATION
TROY, OH 45374

FORMAT 1, 2.375"L

Barcode: < 200030 017386 >

Main market
From us to you!

DESCRIPTION DESCRIPTION
DESCRIPTION

SAFE HANDLING INSTRUCTIONS
THIS PRODUCT HAS BEEN PREPARED FROM INSPECTED AND PASSED MEAT AND OR POULTRY. SOME FOOD PRODUCTS MAY CONTAIN BONE FRIBS THAT COULD CAUSE INJURY IF THE PRODUCT IS SCISSORED OR CUT IN IMPROPERLY. FOR YOUR PROTECTION, FOLLOW THESE SAFE HANDLING INSTRUCTIONS.

KEEP REFRIGERATED OR FROZEN. THAW IN REFRIGERATOR OR COLD WATER.
KEEP BONE MEAT AND POULTRY SEPARATE FROM OTHER FOODS. WASH WORKING SURFACES INCLUDING CUTTING BOARDS, DRENCHES, AND HANDS AFTER TOUCHING RAW MEAT OR POULTRY.
COOK THOROUGHLY. KEEP HOT FOODS HOT, REFRIGERATE LEFTOVERS IMMEDIATELY OR DISCARD.

KEEP REFRIGERATED Sell By: 08-31-08

Net Wt/Ct: 1.74 lb Unit Price: \$ 9.99 Total Price: \$ 17.38

HOBART CORPORATION
TROY, OH 45374

FORMAT 2, 3.00"L

Barcode: < 200040 027634 >

Main market
From us to you!

DESCRIPTION DESCRIPTION
DESCRIPTION

INGREDIENTS

Packed On: 08-28-08 Sell By: 08-31-08

Net Wt/Ct: 1.74 lb Unit Price: \$ 15.88 Total Price: \$ 27.63

HOBART CORPORATION
TROY, OH 45374

FORMAT 3, 3.00"L

DETAILS AND DIMENSIONS

15.94"L x 14.76"W x 5.5"H

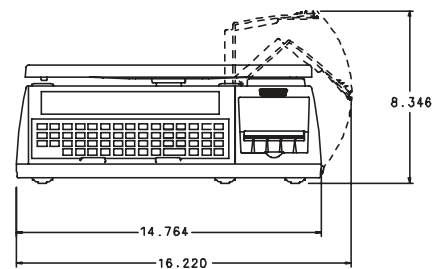
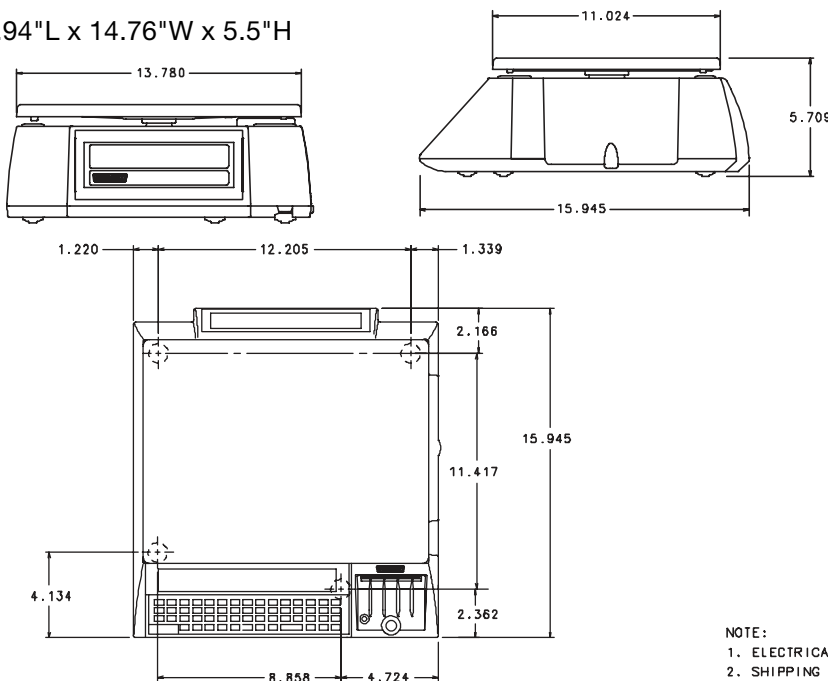

NOTE:
1. ELECTRICAL SPECIFICATIONS: 115/230 VOLTS, 50/60 HERTZ, 1 PHASE.
2. SHIPPING WEIGHT: 24 LBS.

As continued product improvement is a policy of Hobart, specifications are subject to change without notice.