

**HOBART**701 S Ridge Avenue, Troy, OH 45374  
1-888-4HOBART • www.hobartcorp.com**KLEENSCREEN PLUS® FILTER SYSTEM – ELECTRIC FRYERS****HOBART****KLEENSCREEN PLUS® FILTER SYSTEM – ELECTRIC FRYERS****STANDARD FEATURES**

- Filter system accommodates:
  - minimum of two, maximum of four fryer cabinets (HF50F)
  - maximum of three fryer cabinets (HF85F)
- Controls – solid state (D) or computer (C)
- Boil Out ByPass™ removes water or discard oil
- Drain valve interlock switch (DVI)
- 18 gauge, #304 stainless steel filter pan. 70 lbs. frying compound capacity on HF50F, 110 lbs. capacity on HF85F.
- 6" adjustable legs – 2 locking, 2 non-locking
- HF50F and HF85F – paperless stainless steel 2-sided filter screen, surface area 270 square inches. Microfiltration fabric envelope surface area 350 square inches.
- 1/8 H.P. motor and pump circulates hot frying compound at a rate of 8.0 gallons per minute
- Patented one touch button switch to engage pump and motor
- Oil discard hose - 6 ft. in length
- Large primary crumb catch basket
- Tank brush and clean-out rod

**ACCESSORIES**

- Stainless steel tank cover
- Micro-Filtration Fabric Envelopes - 6 filters per package
- Casters, adjustable – locking and non-locking
- 6' high temperature discard hose
- "Add-On" Frymate™ - HX15S and HX21S
- Rear oil reclamation discard connection
- HF85F – single and twin basket lifts

**MODELS****Solid State Controls:**

- |                                  |                                  |                                  |
|----------------------------------|----------------------------------|----------------------------------|
| <input type="checkbox"/> 2HF50DF | <input type="checkbox"/> 3HF50DF | <input type="checkbox"/> 4HF50DF |
| <input type="checkbox"/> 2HF85DF | <input type="checkbox"/> 3HF85DF |                                  |

**Computer Controls:**

- |                                  |                                  |                                  |
|----------------------------------|----------------------------------|----------------------------------|
| <input type="checkbox"/> 2HF50CF | <input type="checkbox"/> 3HF50CF | <input type="checkbox"/> 4HF50CF |
| <input type="checkbox"/> 2HF85CF | <input type="checkbox"/> 3HF85CF |                                  |

Specifications, Details and Dimensions on Reverse Side.



# KLEENSCREEN PLUS® FILTER SYSTEM – ELECTRIC FRYERS



701 S Ridge Avenue, Troy, OH 45374  
1-888-4HOBART • www.hobartcorp.com

## DETAILS AND DIMENSIONS

### IMPORTANT

1. An adequate ventilation system required for Commercial Cooking Equipment. Information may be obtained by writing to the National Fire Protection Association, Batterymarch Park, Quincy, MA 02269. When writing refer to NFPA No. 96.
2. All models require a 6" clearance at both sides and rear adjacent to combustible construction.

3. All models require a 16" minimum clearance to adjacent open top burner units.
4. This appliance is manufactured for commercial installation only and is not intended for home use.

### SERVICE CONNECTIONS:

- (E1) 480 volt HF KleenScreen™ Plus requires a separate 120V, 60 Hz, 1 phase electrical power connection to operate the filter motor/pump and digital controls, (not supplied with the fryer).

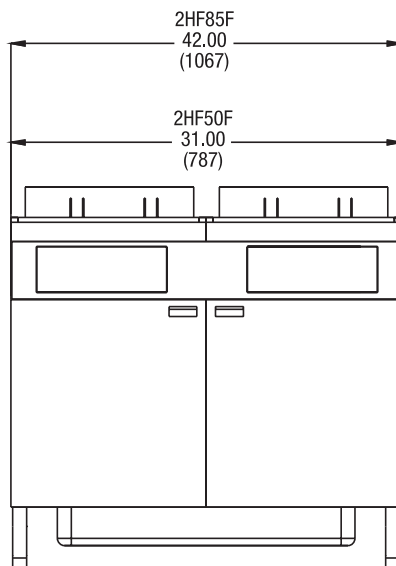
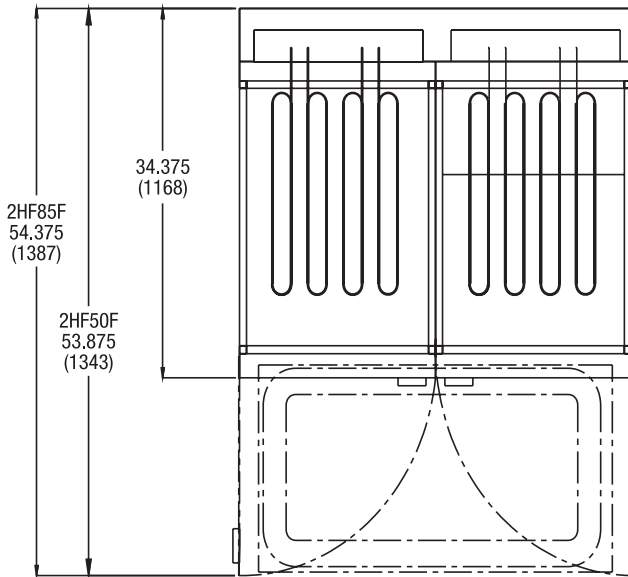

### FILTER PAN CAPACITIES:

1HF50F = 70 lbs.  
1HF85F = 110 lbs.

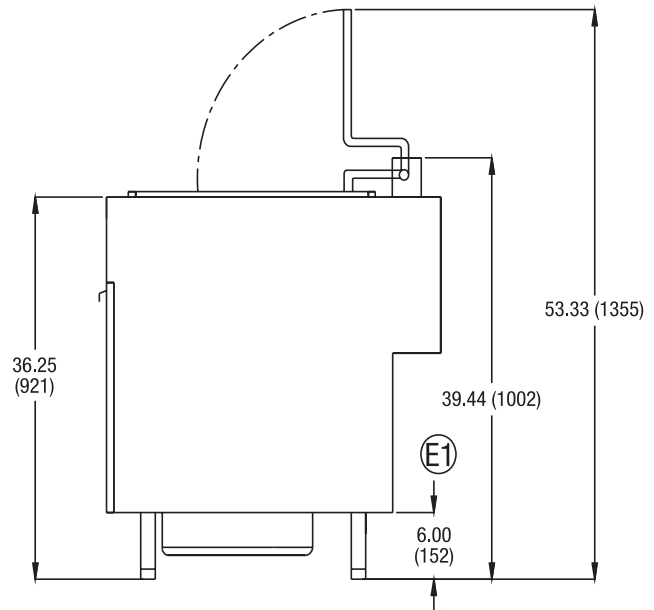

### REFER TO INDIVIDUAL SPEC SHEETS

1HF50F F-8352 for electrical specifications - 17 Kw  
1HF85F F-8349 for electrical specifications - 24 Kw

**FRYER IN BATTERY WITH FUSES (MASTER) MUST ADD 5 AMPS FOR THE MOTOR/PUMP. REMAINING FRYERS (SLAVE) USE AMPS PER SPEC SHEET**

### BATTERY DIMENSIONS

MODEL NO.	2 FRYERS	3 FRYERS	4 FRYERS
	Width	Width	Width
2, 3, or 4HF50F	31"	46½"	62"
2 or 3HF85F	42"	63"	–

### Motor/Pump Specifications for 480V Units:

⅓ H.P. 1750 RPM 8.0 gal./min.  
120V / 5.0A 50/60Hz 1 Ph.

### Motor/Pump Specifications for 208V Units:

⅓ H.P. 1750 RPM 8.0 gal./min.  
208V / 3.6A 50/60Hz 1 Ph.

As continued product improvement is a policy of Hobart, specifications are subject to change without notice.