

HOBART701 S Ridge Avenue, Troy, OH 45374
1-888-4HOBART • www.hobartcorp.com**HGC5X SERIES DEEP GAS
CONVECTION OVENS****HOBART****STANDARD FEATURES**

- Stainless Steel Front, Sides, Top and Back
- Painted Legs
- Stainless Steel Doors with Windows
- 44,000 BTU/hr. Burner per Section, 88,000 BTU/hr. Total Input
- Electronic Spark Ignition
- ½ H.P. Two Speed Oven Blower Motors. 115/60/1 with 6' Cord and Plug, 9 Amps.
- Solid State Temperature Controls Adjust from 150° to 500°F
- 60 Minute Timer with Audible Alarm
- Oven Cool Switch for Rapid Cool Down
- Porcelain Enamel on Steel Oven Interior
- Five Nickel Plated Oven Racks with Eleven Rack Positions per Section
- ¾" Rear Gas Connection with Gas Pressure Regulator and Manual Shut-Off Valve
- Computer Controls with Digital Time & Temperature Readout. Includes Cook & Hold Cycle, Shelf ID, and 24 hr. Timer with Audible Alarm (D Models Only)

OPTIONS

- Stainless Steel Legs
- Cook & Hold Control
- Casters
- 208V or 240V, 60 Hz, 1 Phase Two Speed Blower Motor, ½ H.P.

MODELS

- HGC501X – Single Deck Gas Convection Oven
- HGC501DX – Single Deck Computer Control Gas Convection Oven
- HGC502X – Double Deck Gas Convection Oven
- HGC502DX – Double Deck Computer Control Gas Convection Oven
- HGC504X – Single Deck Gas Convection Oven with Open Stand
- HGC504DX – Single Deck Computer Control Gas Convection Oven with Open Stand

ACCESSORIES

- Extra Oven Rack(s)
- Stainless Steel Drip Pan
- Down Draft Flue Diverter for Direct Vent Connection
- Stacking Kit (HGC501X and HGC501DX only)

Specifications, Details and Dimensions on Inside and Back.

**HGC5X SERIES DEEP GAS CONVECTION OVENS**

HGC5X SERIES DEEP GAS CONVECTION OVENS



701 S Ridge Avenue, Troy, OH 45374
1-888-4HOBART • www.hobartcorp.com

IMPORTANT

1. A gas pressure regulator sized for this unit is included.
Natural gas 3.5" W.C., propane gas 10.0" W.C.
2. An adequate ventilation system is required for commercial cooking equipment. Information may be obtained by writing to the National Fire Protection Association, Batterymarch Park, Quincy, MA 02289. When writing, refer to NFPA No. 96.
3. These units are manufactured for installation in accordance with ANSZ223.1A (latest edition), National Fuel Gas Code. Copies may be obtained from the American Gas Association, 1515 Wilson Blvd., Arlington, VA 22209.
4. Clearances:

	Combustible	Non-combustible
Rear	6"	0"
Sides	6"	0"
5. This appliance is manufactured for commercial installation only and is not intended for home use.

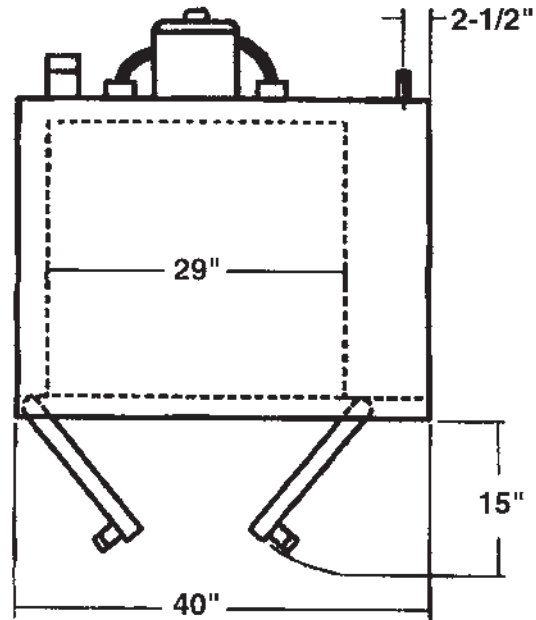

SPECIFY TYPE OF GAS WHEN ORDERING.

SPECIFY ALTITUDE WHEN ABOVE 2,000 FT.

MODEL NO.	WIDTH	DEPTH (INCLUDES HANDLES)	HEIGHT	BTU/HR. PER OVEN	TOTAL BTU/HR.	ELECTRICAL	APPROX. SHP. WT. LBS.
HGC501X HGC501DX	40"	45½"	56¾"	44,000	44,000	115/60/1	500
HGC502X HGC502DX	40"	45½"	70"	44,000	88,000	115/60/1	1,250



701 S Ridge Avenue, Troy, OH 45374
1-888-4HOBART • www.hobartcorp.com

HGC5X SERIES DEEP GAS CONVECTION OVENS

DETAILS AND DIMENSIONS

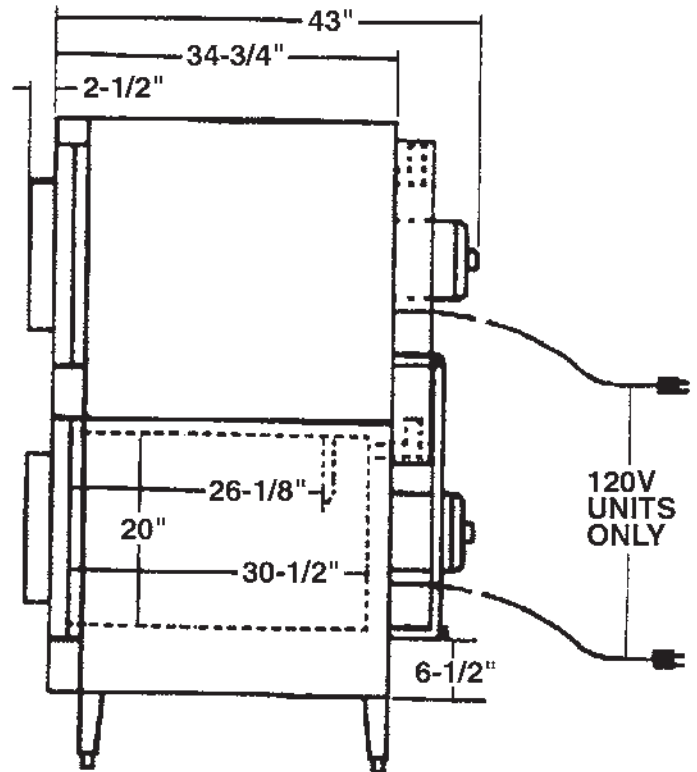
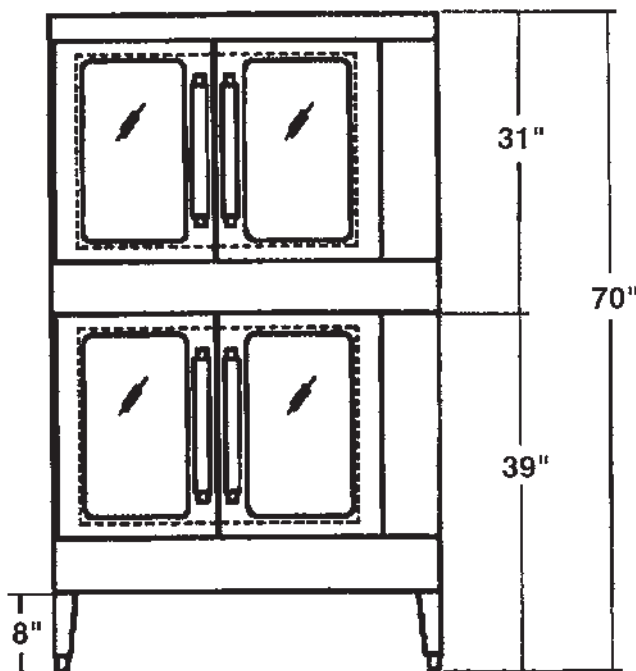
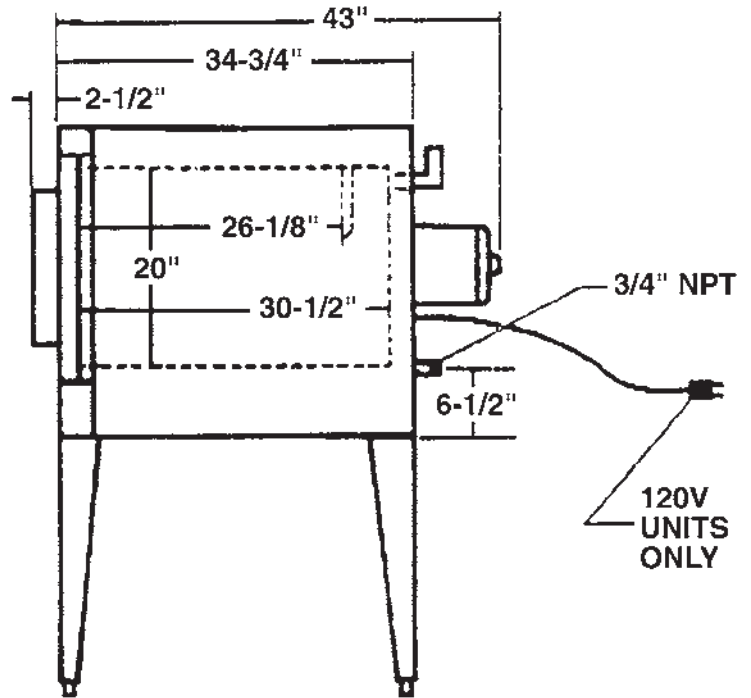
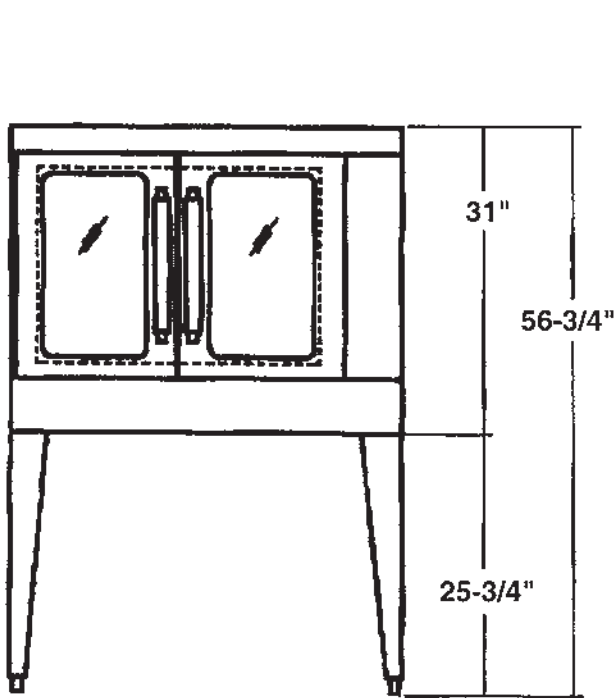

HGC5X SERIES DEEP GAS CONVECTION OVENS



701 S Ridge Avenue, Troy, OH 45374
1-888-4HOBART • www.hobartcorp.com

SPECIFICATIONS

General: Gas convection oven. Basic section (**HGC5X/HGC5DX**) is without legs; may be ordered separately for replacement, for stacking 2-high or for mounting on legs. **HGC501X/HGC501DX** single basic section on 25 $\frac{3}{4}$ " legs. **HGC502X/HGC502DX** two basic HGC5X sections on 8" legs.

Construction: Stainless steel front, sides, top and back, painted legs. Porcelain enamel on steel oven interior. Simultaneously operated stainless steel doors with windows. Two interior oven lights per section. Non-sag insulation applied to the top, rear and sides, bottom and doors.

Oven interior measures 29"w x 26 $\frac{1}{8}$ "d x 20"h. Five nickel plated oven racks per section measure 28 $\frac{1}{4}$ " x 24 $\frac{1}{2}$ ". Eleven position nickel plated rack guides with positive rack stops per section.

Controls: Side mounted temperature controls adjust from 150° to 500°F. 60-minute timer with audible alarm. Oven cool switch for rapid cool down.

"D" models feature side-mounted computer controls adjustable from 150° to 500°F, 24-hour timer with audible alarm, six programmable preset buttons, Cook & Hold and Shelf ID.

Gas: One 44,000 BTU/hr. burner per section. 88,000 BTU/hr. for Model HGC502. Electronic spark igniter.

Electrical: One $\frac{1}{2}$ H.P. two-speed oven blower motor per section. 115/60/1 power supply required. 6 foot cord and plug. 9 amps total draw.

IMPORTANT

WHEN ORDERING: The following must be specified:

- 1) The type of gas
- 2) The altitude when above 2,000 ft.

As continued product improvement is a policy of Hobart, specifications are subject to change without notice.