

HOBART701 S Ridge Avenue, Troy, OH 45374
1-888-4HOBART • www.hobartcorp.com**HBR301-1 BENCH/RECEIVING
DIGITAL SCALE****HOBART****STANDARD FEATURES**

- Easy-to-Read Display
- Legal for Trade
- Battery Power Supply (6) D Cell
- Energy Saver Setting - Set Shutoff Time to Extend Battery Life
- Low Battery Indicator
- Check Weighing
- Batch Weighing
- Over and Under Weighing
- Tilt and Rotatable Display for Easy Viewing
- Toggle Between (Lb./Kg.)
- Stainless Steel Platter
- Tare Indicator
- One Touch and Reset Tare
- Keyboard Tare
- Zero Key
- Stable Weight Indicator
- Net/Gross Weighing
- Automatic Zero Tracking
- AC/DC Adapter
- Leveling Leg Set
- Leveling Indicator

ACCESSORIES

- HBR-301 Stand, Moveable Cart with Swivel Casters, Rear Locks
- Batteries Sold Separately

MODELS

- HBR301-1 300 lb. capacity (150 kg)
- HBR301-160 960 oz. capacity (30 kg)

Specifications, Details and Dimensions on Reverse Side.

**HBR301-1 BENCH/RECEIVING DIGITAL SCALE**

HBR301-1 BENCH/RECEIVING DIGITAL SCALE



701 S Ridge Avenue, Troy, OH 45374
1-888-4HOBART • www.hobartcorp.com

SPECIFICATIONS

CONSTRUCTION:

- Food-safe polymer display. The HBR301 stands up to cleaning and sanitizing.
- Large LCD (1.5" x 0.8"), easy to read digits.
- 90° rotating display.

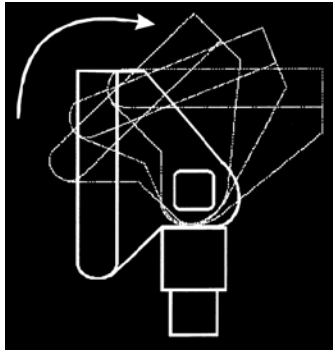

ROTATING DISPLAY

- Platter is stainless steel, stamped construction design sheds juices and food particles.

SELLING FEATURES

- The HBR301 can be used on the bench, floor or moveable cart.
- Receiving scales prevent costly mistakes by accurately check weighing.
- The HBR301 can be used as a bench portion control scale to keep food costs in line.

- The scale tare feature can be set for package or bowl weight to protect profits.
- Easy to clean and sanitize.

TYPICAL LOCATIONS

Bakery - batching
Institutional - portion packaging cold/dry storage
Kitchen Bench - portion control
Receiving Door - check weighing

DETAILS

Weighing System: Strain-gauge loadcell.
Platform: 13.8" x 19.7" (350 x 500 mm), stainless steel.
Weight Display: Single face display.
Type: 7 segment LCD.
Character Size, etc.: 0.5" (12 mm) (W) x 0.9" (23 mm) (GH), 5 digits.
Optional Equipment: Batteries, AC adaptor.
Power Supply: 9V DC - six "D" size batteries or AC adaptor (do wash scale with hose unless the AC jack is sealed).
Consumption: 0.12 W (max.)
Battery Life: 600 hours of continuous use (when using alkaline batteries).
Operating Temperature: 23°F to 95°F (-5°C to 35°C).
Operating Humidity: 25% to 85% RH.
Waterproof Classification: Complies with NEMA 4 (washdown) when the AC jack is plugged with a watertight seal.

Model	Capacity (lb.)	Capacity (oz.)	Capacity (kg)
HBR301-1	*300 x 0.1	4800 x 2	150 x 0.05
HBR301-60	60 x 0.02	*960 x 0.5	30 x 0.01

*Indicates as configured from factory.

DETAILS AND DIMENSIONS

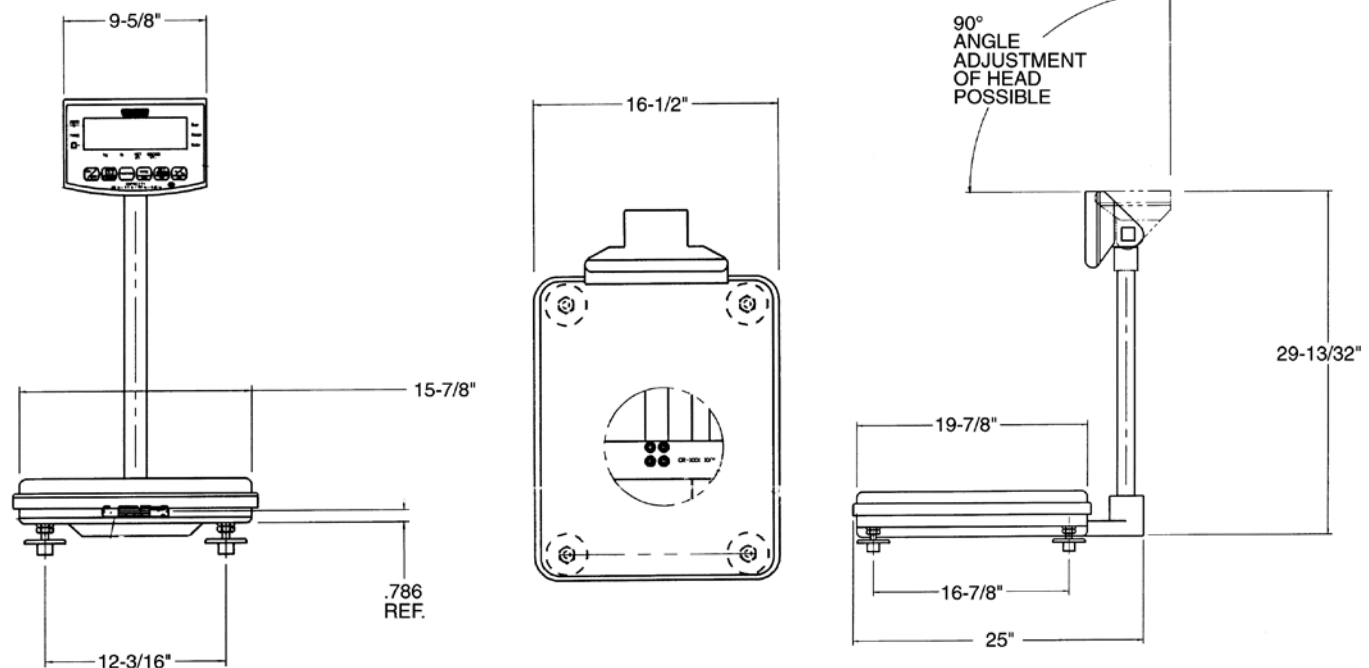

As continued product improvement is a policy of Hobart, specifications are subject to change without notice.