

HOBART701 S Ridge Avenue, Troy, OH 45374
1-888-4HOBART • www.hobartcorp.com**CG10FI GAS
FULL SIZE COMBI OVEN****HOBART****STANDARD FEATURES**

- Multiple cooking modes in one piece of equipment: Convection, Steam and Combination modes achieve Baking, Grill/Roasting, Steaming, Proofing, Rethermalization, Low Temp, Healthy-Fry™, and Delta-T results.
- Gas steam generator combi using indirect steam method.
- Humidity control from 0-100% of possible maximum relative humidity at chosen temperature.
- User friendly right side control panel with large, low voltage LCD display.
- Manual operation or programmable up to 100 recipes with 10 cooking phases each.
- Standard with rack guides and (5) racks.
- Single point external core probe supplied as standard
- 4-speed auto reversing fan.
- Water injection button to add water in convection mode (an automatic process during rapid cool down).
- Halogen lights (3) built into door behind heat reflective glass.
- Flashing door lights & audible alarm system alert user when cooking cycle finished
- Includes Bluetooth communication and recipe software for PC.
- Automatic cleaning programs with auto cool down and auto dosing detergent pump featuring hands free use of built in wash arm operating with non-proprietary cleaning detergent.
- Solid state relay and hydraulic non-mechanical vent.
- Advanced diagnostics with fault history indication, water cooled independent control boards, with LED indicators for service efficiency.
- Cool to the touch & energy efficient heat reflective panoramic curved exterior glass door and insulated panels reflect heat back into the oven.
- Two (2) year parts warranty on control boards, one (1) year parts and labor warranty standard.
- Combi is compatible with Traulsen RBC100 Blast Chiller.

ACCESSORIES

- Wireless Bluetooth® barcode scanner
- HCPC software & wireless communication package for HACCP
- Additional wire rack - full size (standard with five)
- Core probe 1 measuring point with connector (extra)
- Core probe multi measuring points with connector
- Core probe for Sous Vide cooking (2 mm diameter)
- Set of feet (for countertop)
- Stand for 10F Combi: 31½" 24"
- Deluxe stand for 10F Combi: 31½" 24"

MODEL

- CG10FI** – Gas Full Size Combi Oven

ACCESSORIES (Continued)

- Loading table for 10F Combi (for use with the 31½" stand only)
- Removable: Insert Plate insert
- Chicken rack - Holds up to (10) 3 lb. birds per rack
- Heat shield - 10F Combi
- Rack hanger for holding wire racks vertically on external side of unit
- Stacking kit for two gas 10F Combi including support stand
- Fry basket - 12" x 20"
- Grilling grid (rod) - 12" x 20"
- Grilling grid (square) - 12" x 20"
- Convection oven stacking kits
- Gas quick disconnect
- Water Filtration: Your local Hobart representative can recommend a water treatment system to meet the needs of your local water conditions. Our offering includes ScaleStick, ScaleBlocker, Water Softener with De-chlorinator and Reverse Osmosis systems.
- 2nd year parts and labor warranty - 10F Combi
- Preventive maintenance programs by Hobart Service
- Consult factory for additional accessories/options

Specifications, Details and Dimensions on Back.

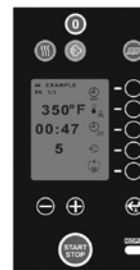
**CG10FI**
Shown with optional stand**CG10FI GAS FULL SIZE COMBI OVEN**

CG10FI GAS FULL SIZE COMBI OVEN



701 S Ridge Avenue, Troy, OH 45374
1-888-4HOBART • www.hobartcorp.com

SPECIFICATIONS:

General: Hobart Combi Oven, gas steam generator, 10 level full size combi.

Construction: All stainless steel interior and exterior. Top, rear, sides, and bottom are fully insulated. All welded stainless steel cooking compartment. Stainless steel oven door features a large curved outer glass with enhanced insulation for a cool to touch exterior, with full length hinged floating inner glass panel. A full perimeter door gasket with drip tray inside door and oven frame. Door opens right to left and swings a full 180 degrees. Standard with rack guides and (5) wire racks. Built in wash arm for automatic cleaning with auto dosing pump, 4-speed auto reversing fan, (3) halogen flashing door lights, external core probe, dual point door latch connection for a full perimeter sealed connection. Standard with 1.6" feet.

Controls: Simple, user friendly digital controls on the right with large, low voltage LCD display - for easy cleaning and operating pleasure. Manual operation or programmable up to 100 recipes with 10 cooking phases each. Includes Bluetooth communication and recipe software for PC.

Operation: Hobart's gas pressureless steam generator and open burner in the cooking cavity uses optimized cooking functions and engineering technology for maximum production with minimal energy and water consumption.

Electrical: 120/60/1 (cord and plug by others).

Gas: 60,000 BTU's, 3/4" gas connection NPT.

Water: 3/4" NSHT cold water, 30-60 psi and 1" NPT drain connection.

Capacity: Capable of holding: (20) 12" x 20" x 2 1/2" steam table pans or (10) 18" x 26" x 1" sheet pans or (20) 13" x 18" x 1" half size sheet pans.

DETAILS AND DIMENSIONS:

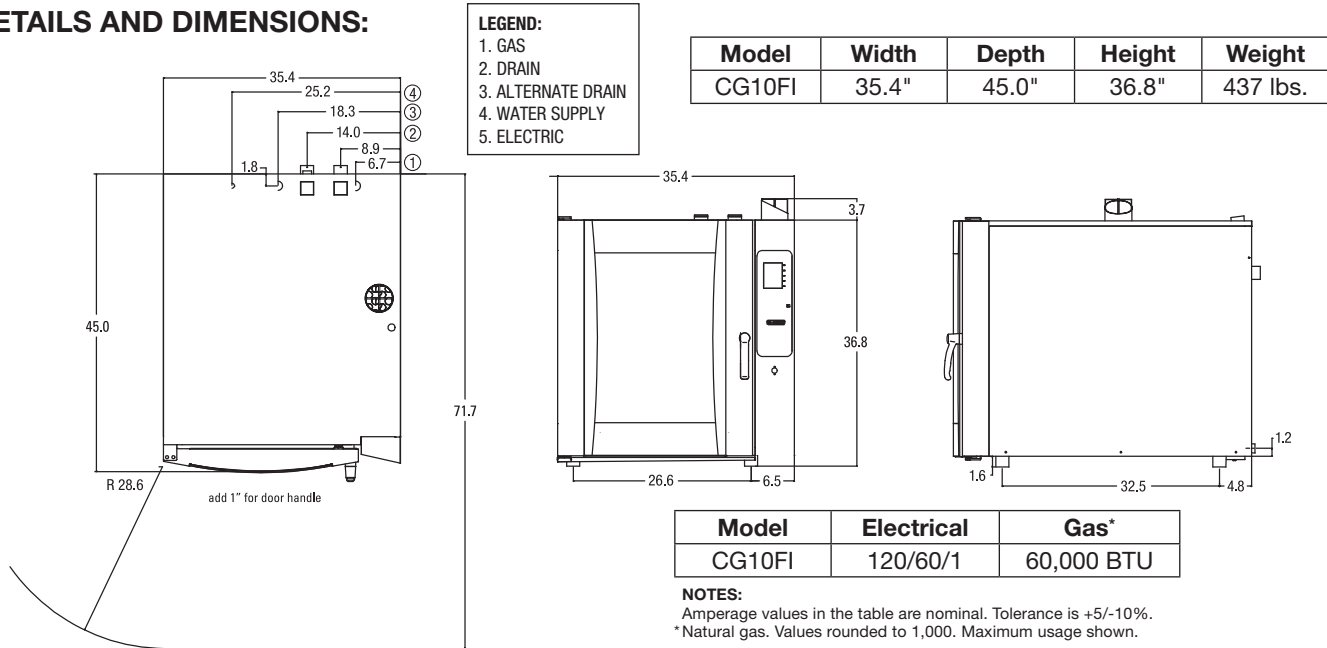

Gas Pressure: A regulator sized for this unit is included. Natural gas 5" W.C., propane gas 10" W.C. supply pressure.

Clearance: Left 1", Back 2", Right 2" required, 18" recommended for service access.

Water Quality Statement

The fact that a water supply is potable is no guarantee that it is suitable for steam generation.

Your water supply must be within these general guidelines:

SUPPLY PRESSURE	30-60 psig
HARDNESS *	less than 3 grains
SILICA	less than 13 ppm
TOTAL CHLORIDE	less than 4.0 ppm
Ph range	7-8
UN-DISSOLVED SOLIDS	less than 5 microns
* 17.1 ppm = 1 grain of hardness	

Other factors affecting steam generation are iron content, amount of chlorination and dissolved gasses. Water supplies vary from

state to state and from locations within a state. Therefore it is necessary that the local water treatment specialist be consulted before the installation of any steam generating equipment.

As with all steam related products, water filtration and regular filter replacements coupled with routine Deliming are required. Your local Hobart office can recommend a water treatment or filtration system to meet the needs of your local water conditions. Contact your local Hobart representative for water treatment offerings.

Note:

- Installation of backflow preventers, vacuum breakers and other specific code requirements is the responsibility of the owner and installer in compliance with local codes.
- Plastic drains are not recommended due to inherent limited temperatures of the plastic. The installer may be required to provide means to reduce water drain temperature to be that of the condensate temperature of 140°F or less. A drain tempering kit is available thru Hobart as an option.

As continued product improvement is a policy of Hobart, specifications are subject to change without notice.