

HOBART701 S Ridge Avenue, Troy, OH 45374
1-888-4HOBART • www.hobartcorp.com**CG SERIES ELECTRIC
COUNTER GRIDDLES****HOBART****STANDARD FEATURES**

- Stainless steel front, sides and 4" adjustable legs.
- ½" thick polished steel griddle plate.
- 13" cooking height on 4" adjustable legs.
- Two solid sheathed tubular incoloy heating elements, one snap action thermostat and cycling light per each 12" griddle width. Thermostats adjust from 200° to 450°F.
- Stainless steel 4" back and tapered side splashes.
- 3⅞" wide front grease trough and a large capacity grease drawer.
- Available in 208V or 240V, 50/60 Hz, 1 or 3 phase power supply. 480V, 50/60 Hz, 3 phase power supply.
- CG58, CG41, CG50 and CG59 models are Energy Star rated.
- One year limited parts and labor warranty.

MODEL

- CG24** 24" wide x 24" deep griddle plate
- CG58** 36" wide x 24" deep griddle plate
- CG41** 48" wide x 24" deep griddle plate
- CG50** 60" wide x 24" deep griddle plate
- CG59** 72" wide x 24" deep griddle plate

Specifications, Details and Dimensions on Inside and Back.



CG41

CG SERIES ELECTRIC COUNTER GRIDDLES

CG SERIES ELECTRIC COUNTER GRIDDLES



701 S Ridge Avenue, Troy, OH 45374
1-888-4HOBART • www.hobartcorp.com

DETAILS AND DIMENSIONS

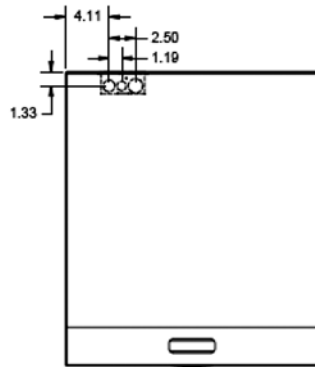

TOP VIEW

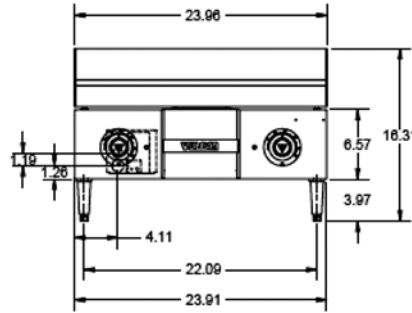

FRONT VIEW

CG24

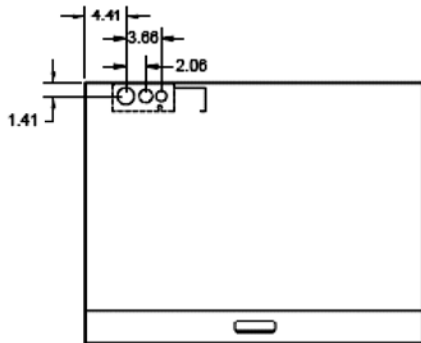

TOP VIEW

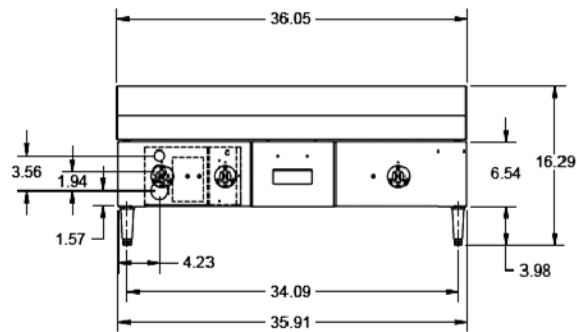

FRONT VIEW

CG58

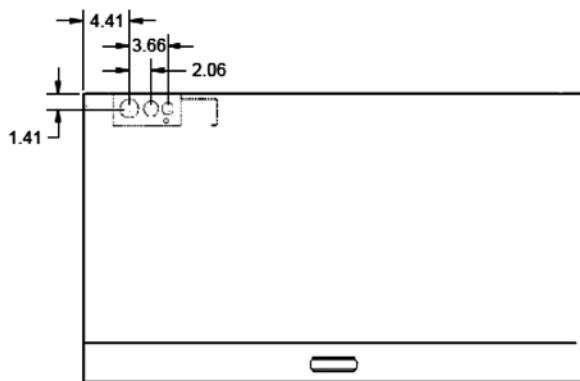

TOP VIEW

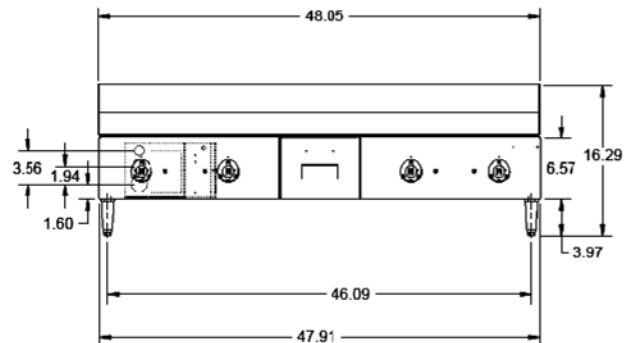

FRONT VIEW

CG41



701 S Ridge Avenue, Troy, OH 45374
1-888-4HOBART • www.hobartcorp.com

CG SERIES ELECTRIC COUNTER GRIDDLES

DETAILS AND DIMENSIONS

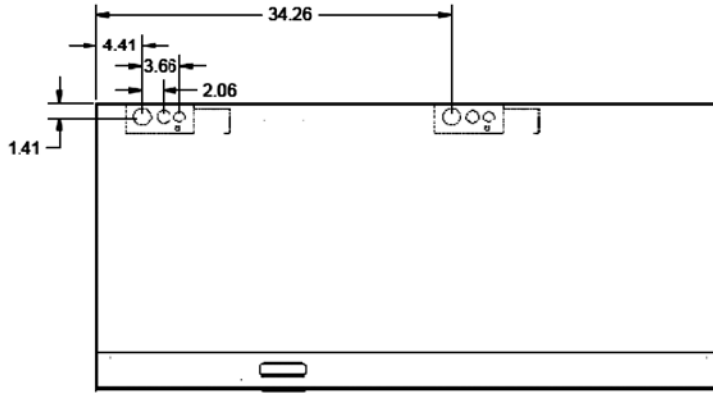

TOP VIEW

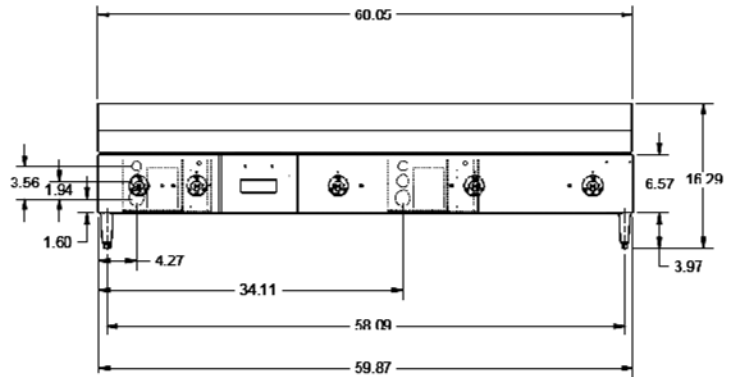

FRONT VIEW

CG50

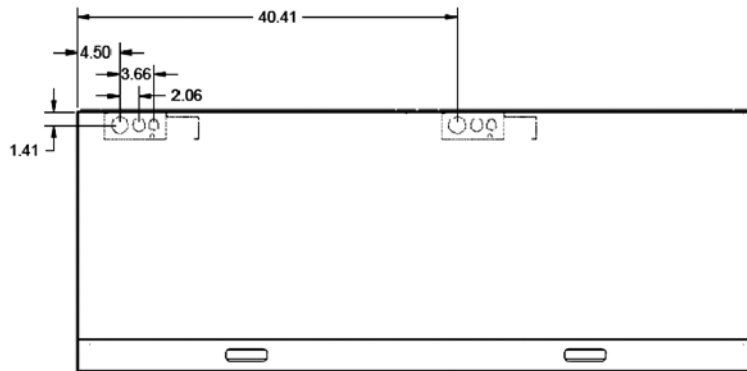

TOP VIEW

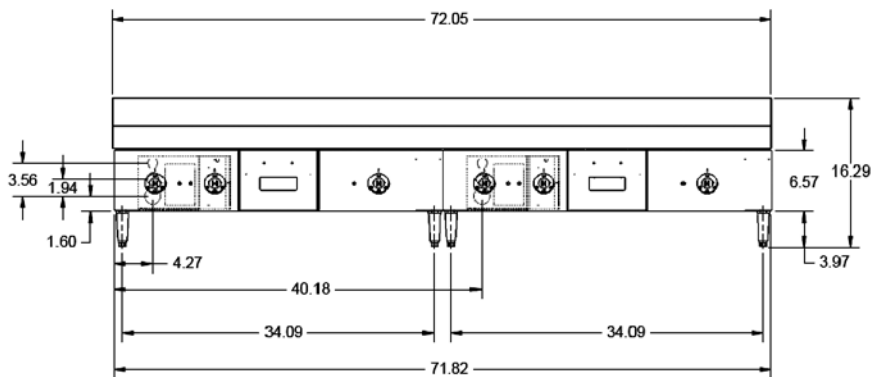

FRONT VIEW

CG59

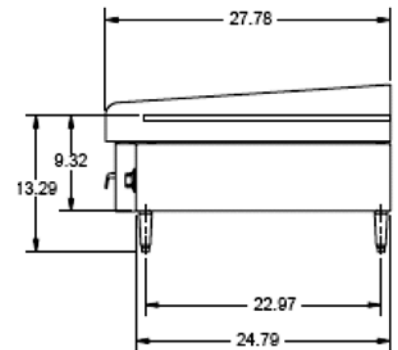

SIDE VIEW
ALL MODELS

CG SERIES ELECTRIC COUNTER GRIDDLES



701 S Ridge Avenue, Troy, OH 45374
1-888-4HOBART • www.hobartcorp.com

SPECIFICATIONS

CONSTRUCTION: Stainless steel free-standing counter-style griddle. Stainless steel heating units with a 1/2" thick polished steel griddle plate. Cold-rolled steel 3" high splatter guard welded to griddle plate bottom. 4" high plastic legs with adjustable feet. A full-width front and rear grease trough directs grease to a removal chute. Full depth grease drawer with weep hole is front removable. (Model CG59 has two grease removal chutes and drawers.) Wrap-around grease guard protects wall and equipment from splatter.

HEATING: Uniform pattern of enclosed tubular stainless steel heating units eliminates hot and cold

spots. Perimeter is heated and units are attached to grid bottom. Extra heat-retaining baffle reduces watts to hold. Preheats to 350°F in just 7 minutes.

CONTROLS: A thermostat provides independent controls of each 12" wide area of grid. Temperature range is 200-450°F. A signal light for each thermostat indicates whether or not that it is operating and when preset temperature is reached.

ELECTRICAL: See Electrical Characteristics chart below. Left rear terminal box. (CG59 power terminal box are at left rear and center rear.) Knockouts in back and bottom permit connections to suit varied conditions.

ELECTRICAL CHARACTERISTICS

STANDARD VOLTAGES – 208 VOLTS OR 240 VOLTS 60 Hz. – SINGLE OR THREE PHASE 480 VOLTS 60 Hz. – THREE PHASE ONLY																
MODEL NO.	TOTAL CONN. KW	TOTAL KW PER CONN	3 PHASE LOADING KW PER PHASE PER CONN.*			NOMINAL AMPS PER LINE WIRE CONN.*										
						3 PHASE									1 PHASE	
						208 VOLT			240 VOLT			480 VOLT			208 VOLT	240 VOLT
X-Y	Y-Z	X-Z	X	Y	Z	X	Y	Z	X	Y	Z	X	Y	Z		
CG24	10.8	10.8	5.4	0.0	5.4	22.5	45.0	22.5	19.5	39.0	19.5	9.7	19.5	9.7	51.9	45.0
CG58	16.2	16.2	5.4	5.4	5.4	45.0	45.0	45.0	39.0	39.0	39.0	19.5	19.5	19.5	77.9	67.5
CG41	21.6	21.6	10.8	5.4	5.4	68.7	68.7	45.2	59.5	59.5	39.0	29.8	29.8	19.5	103.9	90.0
CG50*	27.0	16.2	5.4	5.4	5.4	45.0	45.0	45.0	39.0	39.0	39.0	19.5	19.5	19.5	77.9	67.5
		10.8	5.4	0.0	5.4	45.0	26.0	26.0	39.0	22.5	22.5	19.5	11.3	11.3	51.9	45.0
CG59*	32.4	16.2	5.4	5.4	5.4	45.0	45.0	45.0	39.0	39.0	39.0	19.5	19.5	19.5	77.9	67.5
		16.2	5.4	5.4	5.4	45.0	45.0	45.0	39.0	39.0	39.0	19.5	19.5	19.5	77.9	67.5

*Model CG50 and CG59 require two separate electrical connections and services.

DATA CHART

MODEL NO.	OVERALL DIMENSIONS			GRIDDLE SURFACE DIMENSIONS		SHIP WT. lbs/kg
	WIDTH	DEPTH	HEIGHT	WIDTH	DEPTH	
CG24	24" (610)	27 ⁵ / ₈ " (702)	16 ³ / ₈ " (415)	24" (610)	24" (610)	157/71
CG58	36" (914)	27 ⁵ / ₈ " (702)	16 ³ / ₈ " (415)	36" (914)	24" (610)	230/104
CG41	48" (1219)	27 ⁵ / ₈ " (702)	16 ³ / ₈ " (415)	48" (1219)	24" (610)	275/125
CG50	60" (1524)	27 ⁵ / ₈ " (702)	16 ³ / ₈ " (415)	60" (1524)	24" (610)	420/190
CG59	72" (1821)	27 ⁵ / ₈ " (702)	16 ³ / ₈ " (415)	72" (1821)	24" (610)	560/254

(Dimension in parenthesis are in millimeters)

Installation clearances: Sides and rear must be 1" from the nearest combustible construction and 0" from noncombustible construction. Bottom must be 4" from combustible or non-combustible construction.

As continued product improvement is a policy of Hobart, specifications are subject to change without notice.