

HOBART701 S Ridge Avenue, Troy, OH 45374
1-888-4HOBART • www.hobartcorp.com**ACCESS SEMI-AUTOMATIC
WRAPPING SYSTEM****HOBART****STANDARD FEATURES**

- Semi-automatic wrapping system - operator places package into the Access and weighing and wrapping is done automatically. The operator then hand-applies the label to the finished package.
- Integrated scale reduces floor space requirements
- 2 rolls of film to minimize film usage
- Auto off/on timer for heated sealer belt
- Hose-downable just like the meat saw or mixer grinder
- System automatically shuts down when not in use
- System allows for remote diagnostics/monitoring
- Package range up to 10" L X 16" W X 6" H
- Enlarged scale intake for manual weighing of turkeys and whole hams

ACCESSORIES

- SHELF-ACCESS Folding Side Shelf (Left or Right)
- RBG-2 Rotary Bin Gravity with Casters

MODELS

- AWS-1LR Access Semi-Automatic Wrapping System

OPTIONS AT EXTRA COST

- EPP-1 Access PrePack Printer
- EPCP-1 Access PrePack Control Panel

Specifications, Details and Dimensions on Inside and Back.

**ACCESS SEMI-AUTOMATIC WRAPPING SYSTEM**

ACCESS SEMI-AUTOMATIC WRAPPING SYSTEM



701 S Ridge Avenue, Troy, OH 45374
1-888-4HOBART • www.hobartcorp.com

SPECIFICATIONS

WEIGHING

Capacity – 30 lbs. (Manual) 15 lbs. (Automatic mode)
Weighing increments – .01 lb
Minimum weight to print – .20 lb

WRAPPING

Package Size Width – 4.5" min, 16.0" max
Length – 4.5" min, 10.1" max
Height – .4" min, 6.0" max
Wrapping Speed – Maximum of 30 packages per minute
Number of Film Rolls – 2

Type of Film Used – PVC

Film Thickness – 60 gauge min, 100 gauge max

Film Core Size – 3" I.D.

Film Maximum Diameter – 9.5" O.D.

Film Widths – 13" min, 20" max

ELECTRICAL

120/208-240 (4 wire-2 hot lines, neutral & ground) 60 cycle, 1 phase, 20 amps

SHIPPING WEIGHT

Approximately 1,300 lbs.

DETAILS AND DIMENSIONS

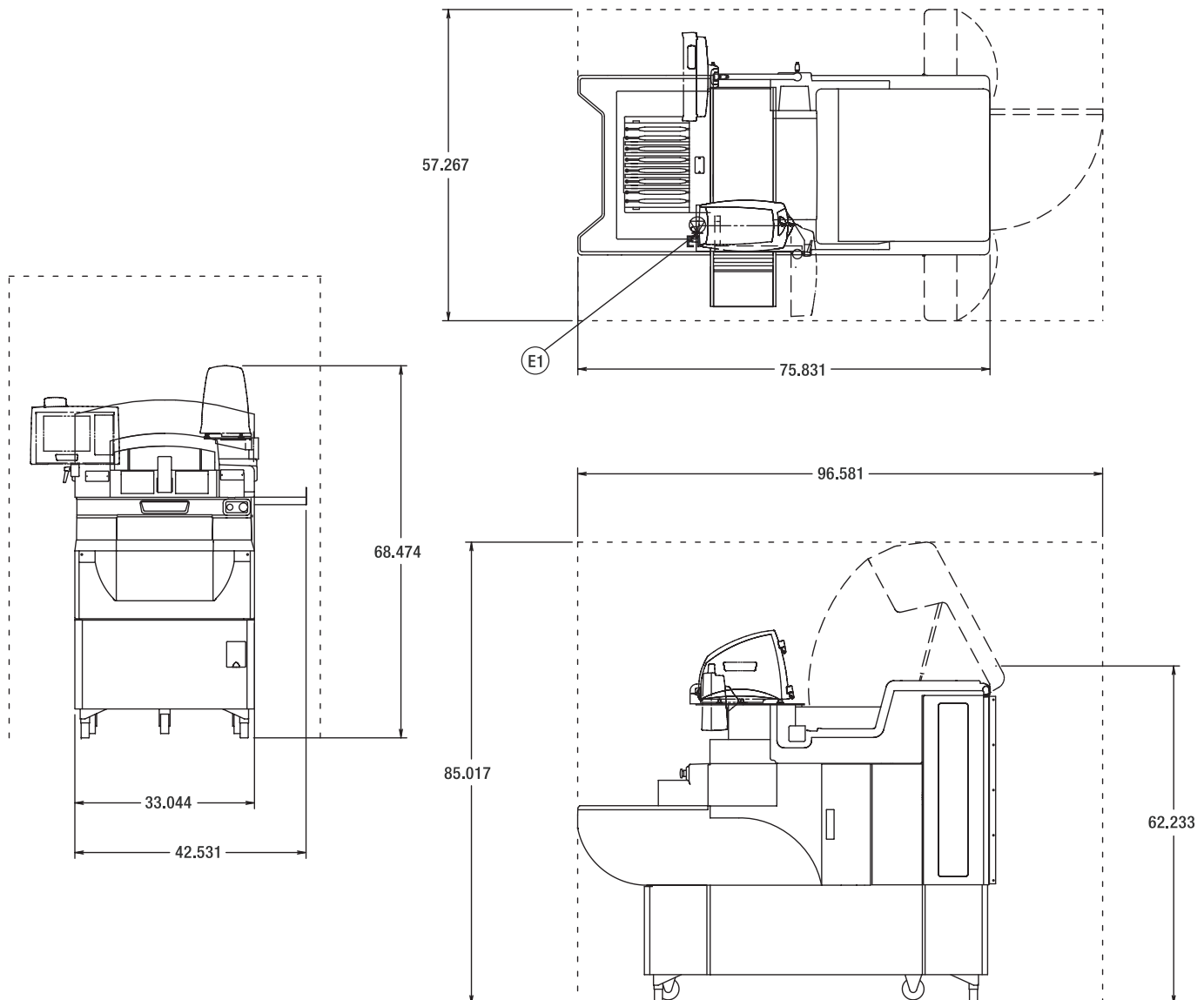

As continued product improvement is a policy of Hobart, specifications are subject to change without notice.