

HOBART701 S Ridge Avenue, Troy, OH 45374
1-888-4HOBART • www.hobartcorp.com**1HF85CF WITH KLEENSCREEN
PLUS® FILTRATION SYSTEM****HOBART****1HF85CF WITH KLEENSCREEN PLUS® FILTRATION SYSTEM****STANDARD FEATURES**

- Computer control with digital character display. Completely programmable with 10 menu driven product keys with compensating time. Adjusts from 200° to 390°F. Multiple melt cycles. Automatic boil out mode. Programmable Celsius and Fahrenheit temperature scales.
- Boil Out ByPass™ removes water or discard oil.
- Drain valve interlock switch (DVI) shuts off heating elements when drain valve is opened or heating elements are raised.
- Drawn (seamless) 18 gauge stainless steel filter pan. 100 lbs. frying compound capacity. Dishwasher safe.
- 6" adjustable legs.
- Paperless stainless steel 2 sided filter area = 462 sq. inches. Microfiltration fabric envelope surface area = 515 sq. inches.
- 1/3 H.P. motor and pump circulates frying compound at a rate of 8.0 gallons per minute.
- Patented one touch button to engage pump and motor.
- High temperature discard hose for flushing and discarding shortening.
- 208 volts, 50-60 Hz, phase
- Large primary crumb catch basket.
- Tank brush and clean-out rod.
- One year limited parts and labor warranty.
- 10 year limited fry tank warranty.

ACCESSORIES

- Stainless steel tank cover doubles as a work top.
- Micro-filtration fabric envelopes – 6 filters/per package
- Casters, adjustable – 2 locking, 2 non-locking – field installed
- Twin baskets
- Single basket
- "Add-On" Frymate - VX21S - field installed
- Single basket lift (single basket included)
- 10" stainless steel removable splashguard – field installed

MODEL

- 1HF85CF with KleenScreen PLUS® Filtration System – Built-in filter system for HF Series Fryers

OPTIONS

- 480 volt, 3 phase. (Separate 120 volt, 20 amp electric supply required.)

Specifications, Details and Dimensions on Reverse Side.



1HF85CF WITH KLEENSCREEN PLUS® FILTRATION SYSTEM



701 S Ridge Avenue, Troy, OH 45374
1-888-4HOBART • www.hobartcorp.com

SPECIFICATIONS

85 lbs. capacity electric fryer, Hobart Model No. 1HF85CF. Stainless steel cabinet. Set of four 6" adjustable legs. Stainless steel fry tank with ribbon style heating elements and large cold zone. 1¼" full port ball type drain valve. Twin or single baskets 208 volt/50-60 cycles/3 phase 24 kW heating elements. Computer control with digital character display. Completely programmable with 10 menu driven product keys. Adjustable from 200° to 390°F. Multiple melt cycles and automatic boil out mode. Programmable Celsius and Fahrenheit temperature scales. Patented Built-in KleenScreen PLUS® filtration system, that accommodates one 85 lb. fryer. Filter pan is constructed of 18 gauge stainless steel. ⅓ H.P. motor and pump circulates hot frying compound at the rate of 8 gallons per minute, activated by a patented solenoid push button switch. Patented system provided standard with paperless stainless steel mesh filter screen. A complimentary package of KleenScreen PLUS® Fabric Envelopes is also included. Standard equipment comes on legs, has a primary crumb catch basket, tank brush and cleanout rod. Hands free oil return line connection. Drain valve interlock switch turns fryer's heating elements off when drain valve is opened or heating elements are raised.

- All models require a 6" (152 mm) clearance at both sides and rear adjacent to combustible construction.
- All models require a 16" (407 mm) minimum clearance to adjacent open top burner units.
- This appliance is manufactured for commercial installation only and is not intended for home use.

SERVICE CONNECTIONS:

- (E1) 480 volt 1HF85CF KleenScreen PLUS® require a separate 120 V, 60 Hz, 1 phase electrical power connection to operate the filter motor/ pump and digital controls, (not supplied with the fryer).

FILTER SYSTEM SPECIFICATIONS:

Filter Area:

Stainless Steel Mesh Screen = 462 sq. in.
Micro Filtration Fabric Envelope = 515 sq. in.

MOTOR/PUMP SPECIFICATIONS for 480V Units:

⅓ H.P. 1750 RPM 8.0 gal./min.
120V/5.0A 50/60 Hz 1 Ph.

MOTOR/PUMP SPECIFICATIONS for 208V Units:

⅓ H.P. 1750 RPM 8.0 gal./min.
208V/3.6A 50/60 Hz 1 Ph.

FILTER PAN CAPACITY:

1HF85CF = 100 lbs.

IMPORTANT

- An adequate ventilation system is required for Commercial Cooking Equipment. Information may be obtained by writing to the National Fire Protection Association, Batterymarch Park, Quincy, MA 02269. When writing refer to NFPA No. 96.

DETAILS AND DIMENSIONS

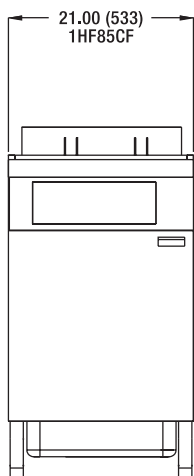

Front View
1HF85CF Series

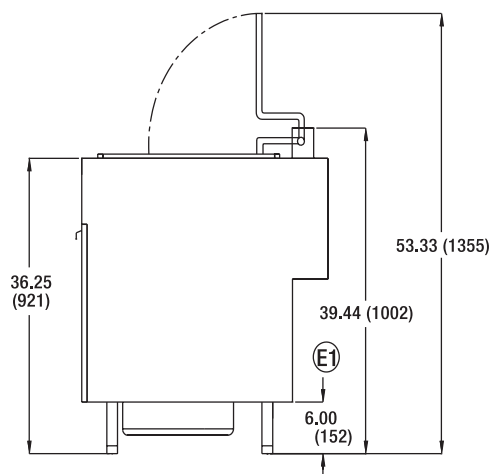

Side View
1HF85CF Series

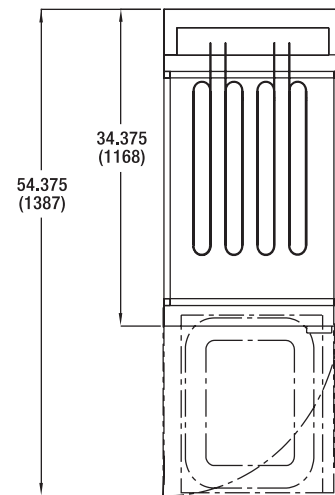

Top View
1HF85CF Series

ELECTRICAL CHARACTERISTICS									
MODEL NO.	TOTAL KW CONN.	3 PH LOADING KW PER PHASE		NOMINAL AMPS PER LINE WIRE					
		208V X-Y	480V X-Z	208 VOLT			480 VOLT		
				X	Y	Z	X	Y	Z
		1HF85CF	24	8	8	67	67	67	29

As continued product improvement is a policy of Hobart, specifications are subject to change without notice.