

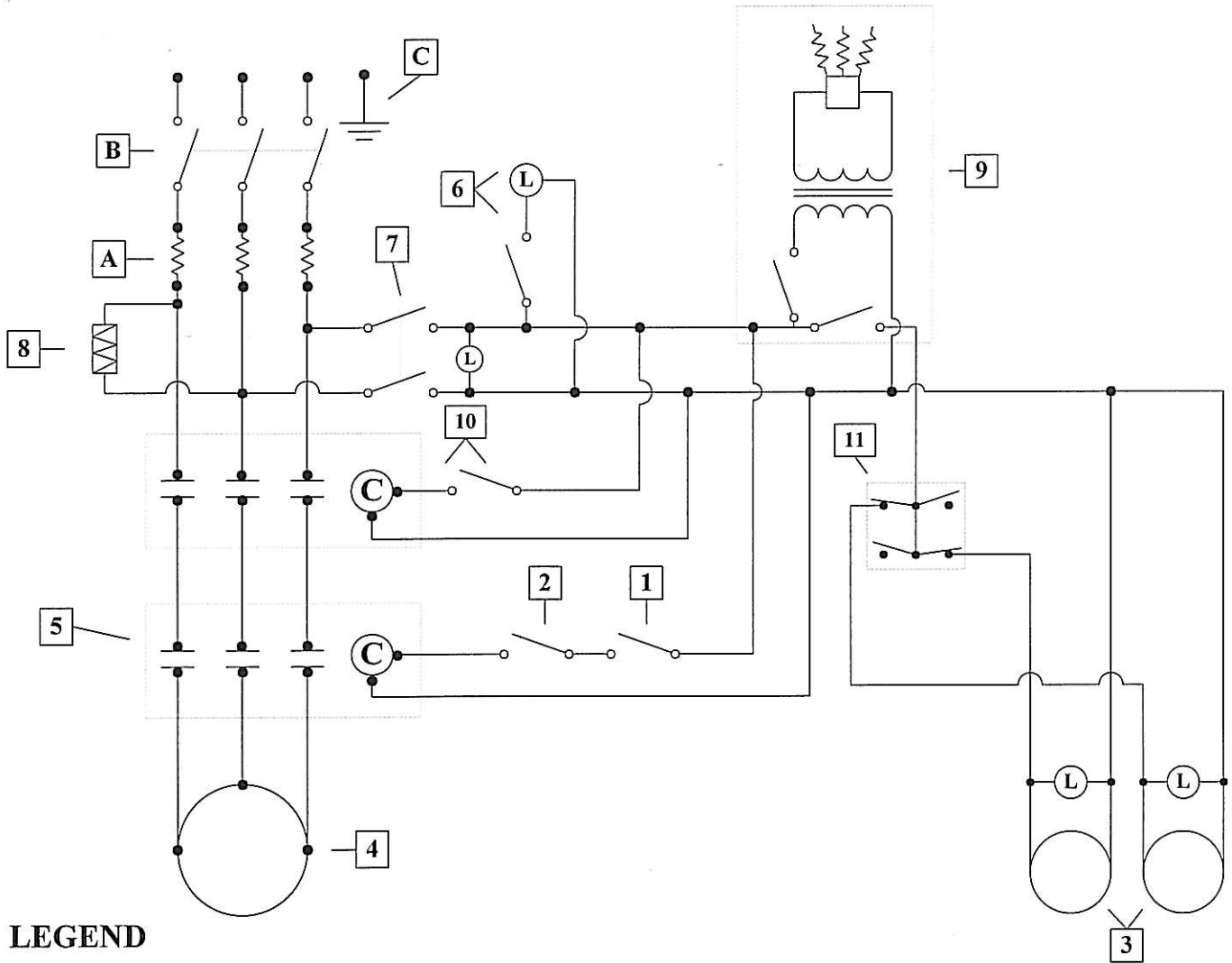

# WIRING DIAGRAM

r300(11)node-itransformer.vsd



## LEGEND

01. Thermostat, refrigeration water temperature control.
02. High/Low refrigerant pressure safety cutout.
03. Two Circulating pump motors (each has thermal protection), Option (D).
04. Compressor motor (has thermal protection).
05. Motor contactor.
06. Liquid level switch and pilot light.
07. System ON-OFF switch and power light.
08. Compressor crankcase heater.
09. High water temperature alarm system and pump cutout. Option (N), two stage.
10. Freeze protection thermostat and contactor.
11. Pump selector switch, 2P3T (ON-ON-ON). Shown in middle position.
12. Pure-Light Indicator and 230/6 VAC Transformer, Option (K).

## ON LOCATION INSTALLATION RECOMMENDATIONS

- A. Time delay fuses. See Front Sheet for size recommendation.
- B. Disconnect service switch.
- C. Ground, connect green wire from cord.

# PIPING DIAGRAM

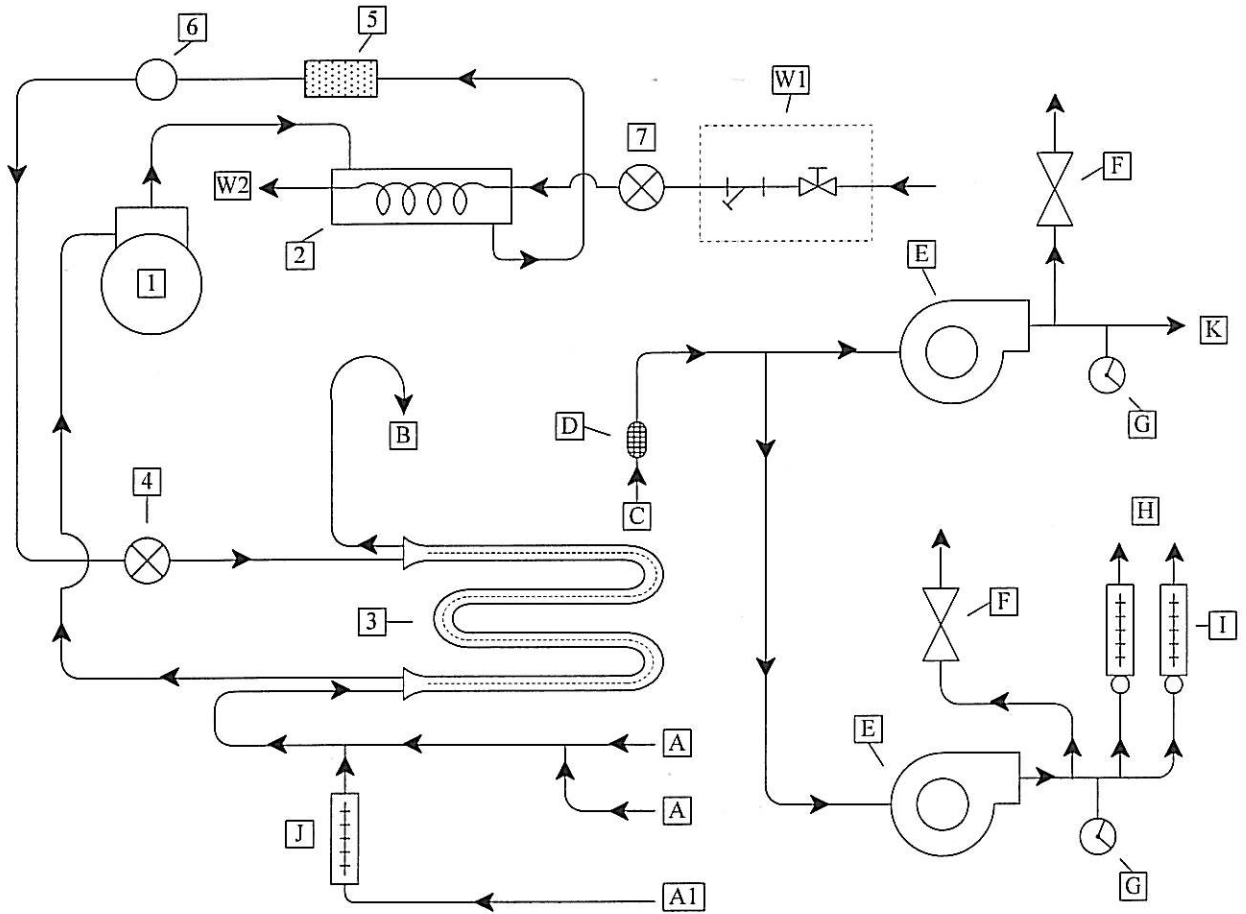

**CONDENSER WATER (OR GLYCOL SOLUTION) TO BE FURNISHED BY OTHERS:**

W1. Source, with Service Valve and Strainer recommended (NOT A FILTER).  
 W2. Discharge to Drain, or Return to "Loop", as applicable.

**LEGEND**

**REFRIGERATION CYCLE**

- 1. Compressor
- 2. Condenser/Receiver
- 3. Evaporator
- 4. Expansion Valve
- 5. Refrigerant Drier
- 6. Sight Glass
- 7. Condenser Water Reg Valve

**CHILLED WATER CIRCUIT**

- A. Two Returns: Turbo Pump and Housing
- A1. Return From Target
- B. Discharge Into Water Storage Tank
- C. Out Of Tank To Pumps
- D. Nylon Suction Strainer (cleanable)
- E. Circulating Pump (2 each)
- F. Relief Valve Back To Tank Through "A" (2 each)
- G. Pressure/Temperature Gauge (2 each)
- H. Two Supplies: Turbo Pump and Housing
- I. Flowmeters With Metering Valves (Turbo/Housing)
- J. Flowmeter Without Metering Valve (Target)
- K. Supply To Target.

# OPTION (K)

## PIPING MODIFICATIONS (Rigaku USA, Inc.)

In conjunction with Option (D), two pump system, this option includes the arrangement of flowmeters in the following configuration:

One pump has a flowmeter without a metering valve in the return line from the Target.

The other pump has two (2) flowmeters with metering valves; one in the supply line to the Housing and one in the supply line to the Turbo Pump.

REFER TO THE PIPING DIAGRAM IN PART 7 OF THIS MANUAL.

# QUALITY ASSURANCE PERFORMANCE TEST

SERIAL NUMBER B15712      MODEL RW500F2      DATE 11-11-04  
 ELECTRICAL 208/230/3/60  
 PIPED BY CK      WIRED BY PF      TESTED BY JL

COMPRESSOR MODEL AA5561 EXT      COMPRESSOR F.L.A. 18  
 COMPRESSOR S/N 313717 K2104      FAN MOTOR F.L.A. \_\_\_\_\_  
 PUMP MODEL ② procon 10YL215      PUMP MOTOR F.L.A. ② 2.9  
 PUMP MOTOR ② Kocutakeu      TOTAL UNIT F.L.A. 23.8

HIGH PRESS CONTROL    OFF 340 ON \_\_\_\_\_      TEMP CONTROL STAT 65 F (OPEN)  
 LOW PRESS CONTROL    OFF 57 ON 75      FREEZE STAT 55 F (OPEN)  
 PUMP RELIEF SETTING 30/40 PSI      HIGH TEMP STAT 75/80 / 80/87 F (OPEN)  
 REFRIGERANT R22      REFRIG CHARGE 18 LBS

AMBIENT TEMP \_\_\_\_\_ F      SUCTION PRESS 75 PSI  
 SUPPLY H2O TEMP 66 F      HEAD PRESS 210 PSI  
 HEAT LOAD 12,000 W      COND UNIT AMPS 13.4 14.9 15 A  
 REHEAT AMPS \_\_\_\_\_ A      PUMP MOTOR AMPS 2.5 2.6 A

VIBRATION CHECK <input checked="" type="checkbox"/> COND FAN BLADE IN BALANCE <input type="checkbox"/> VERIFY ALL CONTROL SETTINGS <input checked="" type="checkbox"/> H2O BLOW OUT OF EVAP/HX <input checked="" type="checkbox"/>	RETIGHTEN ELEC TERMINALS <input type="checkbox"/> LEAK CK WATER SYSTEM AT MAX PRESS <input checked="" type="checkbox"/> REFRIGERANT SIGHT GLASS CLEAR <input checked="" type="checkbox"/> H2O BLOW OUT OF W/C CONDENSER <input checked="" type="checkbox"/>
---	--

OPTIONS:  
① C    ① D    ① K    ① N2

REMARKS:  
PFIZER



every solution is **unique.**

**Optional Design Features**

*Applies to All Haskris Product Platforms*

optional features

**To Tailor for Your Equipment and/or Environment:**

**Option (K):** Used to designate any custom feature you would like built into your unit. Contact Haskris.

**Basic Design Options:**

**Option (C):** Water-cooled condenser with water saver control valve.  
*For refrigerated units only.*

**Option (D):** Two separate water pumping systems.

**Option (R):** Alternate Water Pumps—Contact Haskris

**Option (Y):** Multiple water circuits with flowmeters and metering valves, when cooling more than one piece of equipment from a single pump.

**Option (O):** Hand shut-off valves. Recommended with Option (Y).

**Option (I):** For refrigerated units with air cooled condensers, when ambient air temperatures are excessively high.

**Option (J):** For refrigerated units with air cooled condensers, when ambient air temperatures are excessively low.

**To Protect Your Equipment:**

**Option (B):** High temperature thermostat to de-energize pump motor on a rise in water temperature.  
*Alternately, can be interlocked with your equipment.*

**Option (N):** Alarm system for high water temperature. Choice of “buzzer” only (single stage), or “buzzer” and pump cutout in sequence (two stage).

**Option (S):** Flow switch to provide protection if water flow fails for any reason.

**Option (L):** Supply water filter.

**To Refine or Enhance Performance:**

**Option (G):** Manual refrigerant hot gas bypass system for improved water temperature stability.  
*For refrigerated units cooling a steady heat load. See option(H).*

**Option (H):** Electronically controlled refrigerant hot gas bypass system for improved water temperature stability, to 0.1 C or better.  
*For refrigerated units cooling a variable heat load. Also recommended for refrigerated units with air cooled condensers, when ambient air temperatures are variable and water temperature stability is critical.*

**Option (H):** Electronic close control for improved water temperature stability.  
*For non-refrigerated, water-to-water (WW) units only.*

**Convenience Options:**

**Option (A):** Flowmeter, to visually display flow of water through equipment.

**Option (M):** Time clock, to operate the unit after normal working hours, up to 60 minutes.

**Option (P):** Locking casters (in lieu of standard levelling legs).

**Haskris Company**  
 100 Kelly Street  
 Elk Grove Village, Illinois  
 60007 USA  
 Phone: 001-847-956-6420  
 Fax: 001-847-956-6595  
 Email: sales@haskris.com



every solution is **unique.**

**R500 Platform**

**Refrigerated Water Recirculating Systems**

R500 platform

	with air cooled condenser	with water cooled condenser
Cooling Capacity <small>(at 65°F/18°C supply water temp.)</small>	Watts 15,500 Btu/Hr 52,850	Watts 17,000 Btu/Hr 57,975
Compressor HP	5	5
Refrigerant <small>alternatives available</small>	R22	R22
Water Pump Capacity <small>alternatives available</small>	9 GPM (34.2 LPM)	9 GPM (34.2 LPM)
Pump Motor HP	1	1
Reservoir Volume	30 Gallons (114 Liters)	30 Gallons (114 Liters)
Power Requirements <sup>1</sup> <small>alternatives available</small>	208/230V-3Ø-60Hz 460V-3Ø-60Hz	208/230V-3Ø-60Hz 460V-3Ø-60Hz
Dimensions (W x D x H)	119 x 91 x 142 cm 47 x 36 x 56 in.	76 x 91 x 122 cm 30 x 36 x 48 in.
Shipping Weight	900 Lbs. (408 Kg)	650 Lbs. (295 Kg)

- **Unit specifications will change by adding certain options.**
- Cooling capacity of air-cooled units is based on 80°F/27°C ambient air temperature. Allowable ambient temperature range is 40°F to 100°F (4°C to 38°C). Changes in air temperature will affect cooling capacity. See Haskris Options (I) and/or (J) to operate outside this range.

<sup>1</sup> Also available in 50Hz—contact Haskris



**Haskris Company**  
100 Kelly Street  
Elk Grove Village, Illinois  
60007 USA

Phone: 001-847-956-6420  
Fax: 001-847-956-6595

Email: sales@haskris.com

**Packaging - Processing**  
**Bid on Equipment**  
1-847-683-7720  
[www.bid-on-equipment.com](http://www.bid-on-equipment.com)



100 Kelly Street  
Elk Grove Village, IL 60007 USA

Phone: 847-956-6420

Fax: 847-956-6595

<http://www.haskris.com>

## Water Treatment for Biological Growth

Following are some suggestions regarding water treatment for biological growth. Please keep in mind that any additive must have the prior approval of the manufacturer of the equipment being cooled.

It is important that you fill the system with clean, potable distilled water.

Check the system after one week of operation. If algae start to form, flush the system in accordance with one of the following methods:

### **METHOD 1:**

Add one cup of chlorine bleach per 15 gallons of water. Circulate 20-30 minutes. Drain the system and refill with clean, potable distilled water.

### **METHOD 2:**

Add one pint of hydrogen peroxide per 15 gallons of water. Circulate 20-30 minutes. Drain the system and refill with clean, potable distilled water.

Once the system has been flushed, we recommend that you proceed with one of the following water additives:

### **ADDITIVE 1:**

A 10% solution of lab grade (no additives) ethylene glycol is recommended.

### **ADDITIVE 2:**

Dichlorophene. This is a non-soluble white powder. It is a fungicide/bactericide and should be sprinkled evenly across the water surface of the entire tank.

Haskris Co. does not sell this product, but we have the following source for you to call:

ICN Biomedicals, Inc., P.O. Box 5023, Costa Mesa, CA 92626, Phone: 800-854-0530  
Dichlorophene Catalog # 05201981

### **ADDITIVE 3:**

Chlorine, 8 parts per million.

**NOTE:** A 5 micron filter is very helpful in keeping the system clean, especially if used in conjunction with one of the additives described above.

If you have any questions, please give us a call.