

HAMILTON STYLE "VT"

Sanitary-design
Vacuum Cookers

Standard capacities from
30 to 150-gallons.

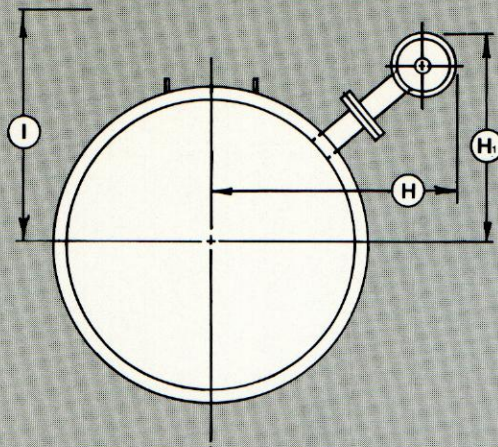

Custom-crafted from standard components

The Style VT vacuum cookers are used effectively for *smaller capacity* processing of jams, jellies, apple butters, preserves, tomato pastes and purees, as well as many other foods.

Cooking under vacuum permits the evaporation of moisture from a product at much lower than atmospheric temperatures (120° F to 180° F), and thus speeds-up cooking. At this lower processing temperature, the natural flavor, high vitamin and nutrient content of even delicate raw fruits, and the light, natural color are retained. Food darkening and discoloration are prevented.

Style VT vacuum cookers are totally-sanitary, stainless steel designs, manufactured for ease of cleaning. Fabrication may be in either Type #304 or Type #316 stainless steel, with kettle polished to a satin finish inside and a semi-deluxe buff outside. Design features tilting top which can be opened in seconds, so it is ideally suited to smaller batches, to load ingredients and between-batch clean-ups. The tilting domed top is counterbalanced so anyone can easily open and close it. The rubber gasketed joint ensures a positive seal between dome and kettle. Specially-designed Hamilton quick-release flip latches secure dome to kettle.

Kettle is a full hemisphere design, two-thirds jacketed with balloon-type steam jacket built for either 40 psi or 90 psi steam working pressure. Pressure zone metal thickness conforms to manufacturer's standard or latest ASME Code. ASME approved safety valves, thermometers, vacuum gauges, vacuum breaker valves, sight glasses and stainless steel water spray condenser are standard equipment on all sizes.

Units are supported on aluminum-finished steel tubular legs with totally enclosed stainless steel sockets and screw-type leveling feet.

Wide range of accessories, options

- BRIGHT-ON® electropolish finish
- Hamilton type Number 1 single motion agitator which decreases processing time
- Simplicity Circulator, a unique stainless steel immersion heating unit for increased heat transfer and product circulation
- vacuum pump which is sized to pull a 26 to 28-inch vacuum
- sanitary 1.17 cubic inch spoon sampler
- process refractometer, an in-stream continuous reading instrument, which provides Brix percent readings — three models, 0-25%; 12-72%; 36-82%
- choice of product discharge valves — sanitary plug flush type; or lever-operated sanitary flush ball type
- light and shade for sight glass

(Warning: Agitator must be stopped before removing cover or reaching inside kettle.)

Specifications and dimensions shown are standard and correct at the time of printing. They may be modified to coincide with specific customer requirements. The company reserves the right to change or alter specifications and designs or to discontinue manufacture without notice or without incurring obligation.

HAMILTON
STYLE "VT"

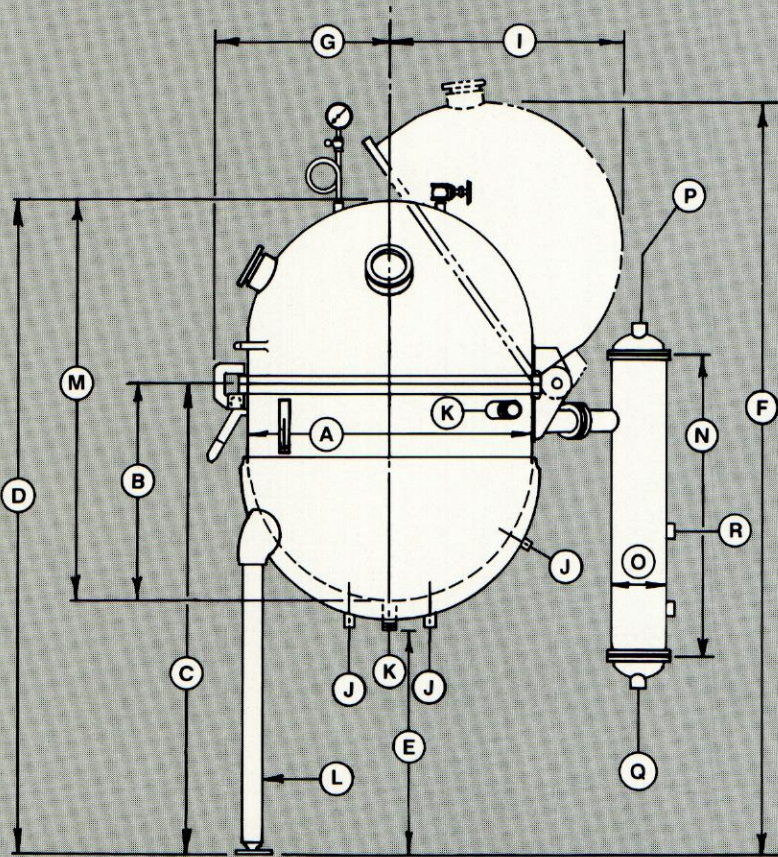

Precision-built agitator assembly

The Hamilton VT vacuum cooker can be supplied with a single motion agitator as an additional option, to provide a simple stirring motion increasing heat transfer to reduce cooking time. The entire heated kettle surface is scraped clean by removable sanitary nylon scrapers.

CAP. U.S. GAL.	A	B	C	D	E	F	G	H	H _i	I	J (NO.) AND DIA. OF STEAM CONN'S.	K DIA. OF OUTLET	L (NO.) AND SIZE OF LEGS	M	N	O	P DIA. CON-DENSER INLET	Q DIA. CON-DENSER OUTLET	R DIA. VAC. PUMP CONN.
30	25"	18½"	45½"	61¼"	22¾"	73"	16½"	29"	16¾"	30¼"	(2) ¾"	1½"	(3) 2"	34"	34"	6"	1½"	1½"	1¼"
50	30"	22½"	50¼"	69¼"	23½"	82¾"	19"	31¼"	18"	36"	(2) ¾"	1½"	(3) 2"	41¼"	34"	6"	1½"	1½"	1¼"
60	32"	24"	52"	72¼"	23¾"	87"	20"	32⅞"	18½"	38"	(2) 1"	1½"	(3) 2"	44"	34"	6"	1½"	1½"	1¼"
80	36"	25"	53¼"	75"	24"	92½"	22"	28¼"	28¼"	44½"	(2) 1"	2"	(3) 3"	46½"	38"	7"	1½"	2"	1¼"
100	38"	28"	57½"	81¼"	25¼"	98½"	23"	29"	29"	48¾"	(3) 1"	2"	(3) 3"	51½"	38"	7"	1½"	2"	1¼"
150	44"	33"	63½"	91¼"	26¼"	110½"	26"	31⅞"	31⅞"	57"	(4) 1¼"	2"	(4) 3"	60½"	42"	8"	1½"	2"	1¼"

HAMILTON

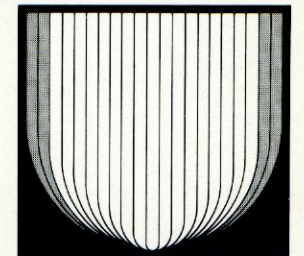

KETTLES

Packaging - Processing
Bid on Equipment

1-847-683-7720

www.bid-on-equipment.com