

HAMILTON STYLE "SB"

Sanitary-design *Shallow*
Kettles and Mix Cookers

Standard capacities from
15 to 350 gallons; larger
and smaller sizes available
to meet specific require-
ments.

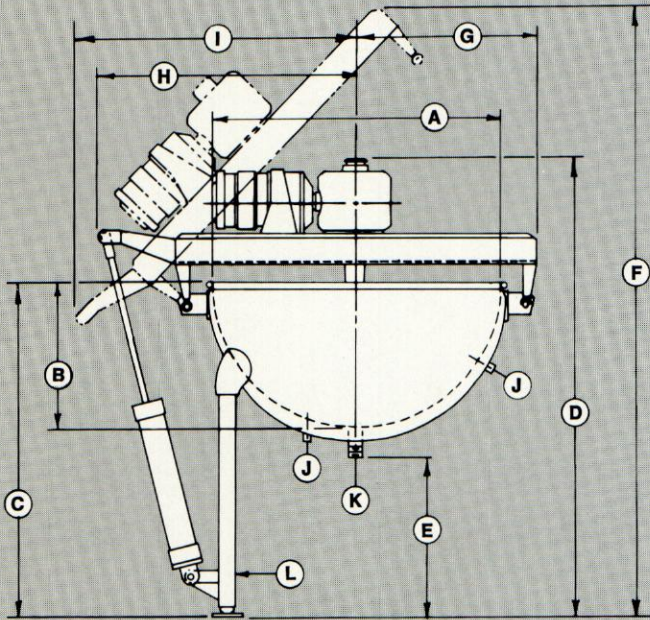
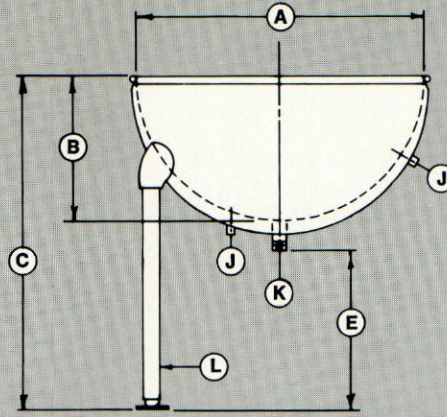

Custom-crafted from standard components

The Style SB kettle and mix cooker is a shallow design with a streamlined balloon-type jacket which comes to within approximately two-inches of the brim. This construction provides the greatest heating/cooling surface for a particular capacity. Style SB kettles and mix cookers are especially well-suited to processing meats and other heavy foods where agitation is minimal and boiling-over is no hazard. Design assures easy cleaning and highest sanitation for maximum product purity.

Kettles and jackets are fabricated of Type #304 stainless steel as standard, with Type #316 stainless steel and other metal combinations available. Each unit has heavy construction for pressures of 40, 90, 125 psi. Units are finished inside to a satin polish, outside to a semi-deluxe buff.

Pressure zone metal thickness conforms to manufacturer's standards or latest ASME code. ASME approved steam safety valves are provided.

Units are supported on aluminum-finished steel tubular legs with totally-enclosed sockets and screw-type, adjustable leveling stainless steel feet. Sanitary polished stainless steel legs available.

Precision-built agitator assembly

The Hamilton SB mix cooker can be supplied with three basic agitators, single motion, double motion or patented triple action designs.

Single motion agitation is used when the product to be processed is a liquid of light viscosity requiring simple stirring motion to decrease cooking/cooling time and keep product in suspension.

Double motion agitators have counter-rotating anchor frame and bar blades which set up counter-currents for more thorough mixing, even heat distribution and faster cooking or cooling.

The unique triple action agitator is used for high-speed mix cooking and cooling of products varying from heavy pastes to light creams, with secondary agitator furnished to meet specific processing requirements.

All parts of the agitator in contact with the product are stainless steel polished to a satin finish. (The entire heated/cooled surface of the kettle is scraped clean by nylon scrapers.)

The agitator drive is a totally-enclosed, A.C., constant speed, gearhead H.D. motor 230/460 volts, 3-phase, 60-Hertz, design. Infinitely variable speed motors are available at extra-cost for all types of agitators. Explosion-proof enclosures are also offered. Agitator and drive are supported by a hinged stainless steel sanitary support bridge. Hydraulic lift-out units are optionally available on the Style SB mix cooker (see below). Other options, accessories and extras include:

- Thermometer connection and guard
- Product outlet valves
- Various style covers
- BRIGHT-ON® electropolish finish
- Hydraulic or pneumatic agitator lift
- Variable speed agitator drive

(Warning: Agitator must be stopped before removing cover or reaching inside kettle.)

Specifications and dimensions shown are standard and correct at the time of printing. They may be modified to coincide with specific customer requirements. The company reserves the right to change or alter specifications and designs or to discontinue manufacture without notice or without incurring obligation.

CAP. U.S. GAL.	STD. H.P. CONST. SPD.	APPROX. AGIT. SPD. RPM, SINGLE MOTION	APPROX. AGIT. SPD. RPM, DOUBLE MOTION	A	B	C	D	E	F	G	H	I	J (NO.) AND DIA. OF STEAM CONN'S.	K DIA. OF OUT- LET	L (NO.) AND SIZE OF LEGS
15	—	—	—	25"	12½"	36½"	—	21"	—	—	—	—	(2)-¾"	1½"	(3)-2"
30	¾	30	30	30"	15"	39"	56½"	21"	70½"	19⅞"	32¾"	35¼"	(2)-¾"	1½"	(3)-2"
50	¾	25	25	36"	18"	43"	60½"	22"	79"	22⅞"	35¾"	38"	(2)-1"	2"	(3) 2"
60	¾	25	25	38"	19"	44"	61½"	22"	81"	23⅞"	38⅞"	40½"	(3)-1"	2"	(3)-2"
80	1	20	20	42"	21"	46"	63½"	20¾"	85¾"	26⅞"	40⅞"	42½"	(3)-1¼"	2"	(3)-3"
100	1	20	20	44"	23"	48"	65½"	20¾"	89"	27⅞"	41⅞"	43½"	(3)-1¼"	2"	(3)-3"
150	1½	17	17	52"	26"	51"	71¼"	20¾"	98"	31¼"	46"	48"	(3)-1¼"	2"	(3)-3"
	2	17	17	56"	28½"	53½"	73¾"	20¾"	103"	33¼"	53⅞"	53"	(3)-1¼"	2"	(4)-3"
	2	14	14	62"	31"	56"	76¼"	20½"	109"	36¼"	56⅞"	55"	(3)-1½"	3"	(4)-3"
350	3	14	14	67"	34½"	59½"	79¾"	20½"	117"	38¾"	58⅞"	60¾"	(3)-1½"	3"	(4)-3"

HAMILTON
STYLE "SB"

HAMILTON

Packaging - Processing

Bid on Equipment

1-847-683-7720

www.bid-on-equipment.com

KETTLES