

HAMILTON STYLE "PC"

Sanitary-design stainless steel pressure cookers

Standard capacities from 15 to 500-gallons; larger sizes available to meet specific requirements.

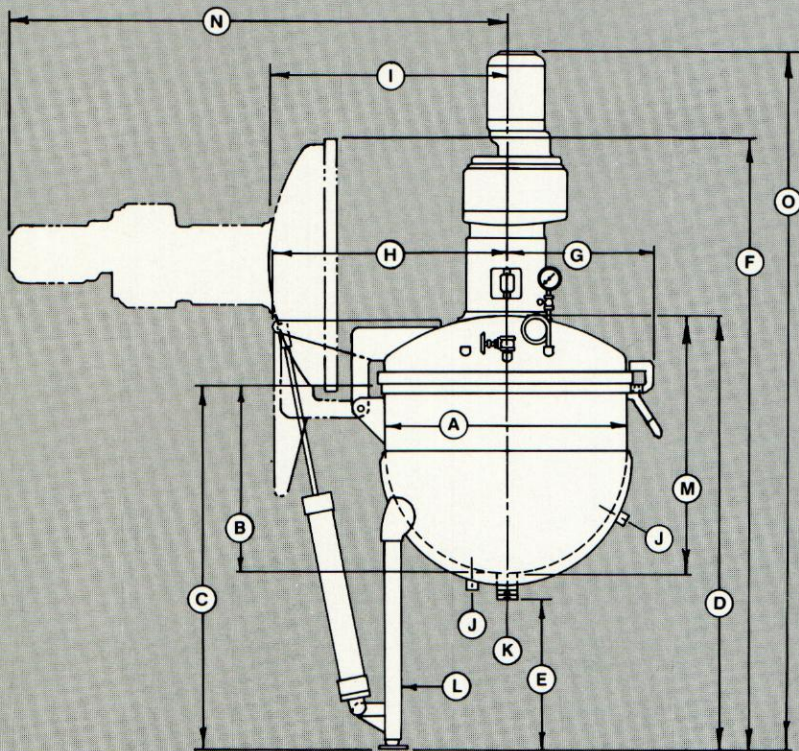
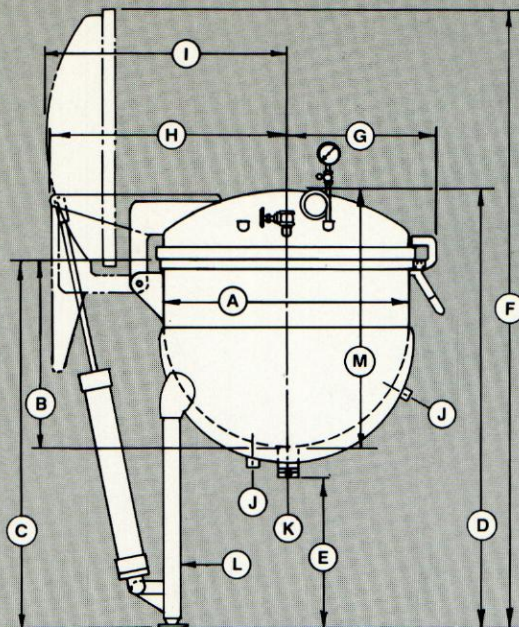

CAP. U.S. GAL.	STD. H.P. CONST. SPD.	APPROX. AGIT. SPD. RPM. SINGLE MOTION	A	B	C	D	E	F	G	H	I	J (NO. AND DIA. OF STEAM CONN'S.)	K DIA. OF OUTLET	L (NO. AND SIZE OF LEGS)	M	N	O
15	—	—	22"	14"	38"	42 3/4"	19 1/2"	60 1/2"	15"	25"	21 1/4"	(2) 3/4"	1 1/2"	(3) 2"	18 3/4"	—	—
20	—	—	23"	16"	40"	44 3/4"	19 1/2"	63 1/2"	15 1/2"	25 1/2"	22 1/4"	(2) 3/4"	1 1/2"	(3) 2"	20 3/4"	—	—
30	3/4	36	25"	18 1/2"	42 1/2"	48"	19 1/2"	68 1/4"	16 1/2"	26 1/2"	24"	(2) 3/4"	1 1/2"	(3) 2"	24"	56 1/4"	80 3/4"
50	3/4	36	30"	22 1/2"	46 1/2"	53"	19 1/2"	77 1/4"	19"	29"	27 1/2"	(2) 3/4"	1 1/2"	(3) 2"	29"	60 1/4"	85 3/4"
60	3/4	36	32"	24"	48"	54 3/4"	19 1/2"	80 3/4"	20"	32"	28 3/4"	(2) 1"	1 1/2"	(3) 2"	30 3/4"	61 1/2"	87 1/2"
80	1	29	36"	25"	50"	57 3/8"	20 1/2"	86 3/4"	22"	34"	35 3/8"	(2) 1"	2"	(3) 2"	32 3/8"	68 3/4"	90 1/4"
100	1	29	38"	28"	53"	60 1/2"	20 1/2"	91 3/4"	23"	35"	36 1/2"	(3) 1"	2"	(3) 2"	35 1/2"	69 1/4"	93 1/4"
150	1 1/2	20	44"	33"	58"	66 1/8"	20 1/2"	102 3/4"	26"	38"	40 7/8"	(3) 1 1/4"	2"	(3) 3"	41 7/8"	81"	107"
2	20	48"	36"	61"	70 3/8"	20 1/2"	109 3/4"	28"	40"	43 3/8"	(3) 1 1/4"	2"	(3) 3"	45 3/8"	83 3/4"	110 1/4"	
2	20	52"	39"	64"	74 3/8"	20 1/2"	116 3/4"	30"	42"	46 3/8"	(3) 1 1/4"	2"	(3) 3"	49 3/8"	86 1/4"	114 1/4"	
300	3	17	56"	41"	66"	76 1/8"	20 1/2"	122 3/4"	32"	46"	50 7/8"	(3) 1 1/4"	2"	(4) 3"	51 7/8"	99 1/4"	125 1/8"
400	3	14	62"	44"	69"	81 1/4"	20 1/2"	132"	35"	49"	55 1/4"	(3) 1 1/2"	3"	(4) 3"	56 1/4"	103 3/4"	129 1/2"
500	3	14	67"	47"	72"	85"	20 1/2"	140"	37 1/2"	51 1/2"	58 1/2"	(3) 1 1/2"	3"	(4) 3"	60"	106 3/4"	133 1/4"

(Warning: Agitator must be stopped before removing cover or reaching inside kettle.)

Specifications and dimensions shown are standard and correct at the time of printing. They may be modified to coincide with specific customer requirements. The company reserves the right to change or alter specifications and designs or to discontinue manufacture without notice or without incurring obligation.

Printed in U.S.A.

Custom-crafted from standard components

The Style PC pressure cooker is designed especially for meat and poultry processing, and is used effectively with certain other foods which benefit from fast pressure cooking. Streamlined balloon-type steam jacket covers two-thirds of kettle, providing optimum heated area.

Design and construction are completely sanitary. Stainless steel kettles are finished to a satin polish inside, and a semi-deluxe buff outside. Aluminum finished steel tubular legs have totally-enclosed stainless steel sockets and adjustable leveling feet. Kettle-cover gasket is white neoprene rubber, odorless and tasteless.

Style PC pressure cookers are constructed for pressures of 90 psi in jacket and 15 psi inside kettle. Pressure zone metal thickness conforms to manufacturer's standard or latest ASME Code. Fabrication may be in either Type #304 or Type #316 stainless steel. ASME approved safety valves are provided as standard. Pressure gauge, bronze pressure break valve and plugged thermometer coupling are supplied in the cover.

The dished stainless steel cover is secured by Hamilton's specially-designed quick-opening flip latches. The cover is simply raised by a water actuated hydraulic lift as standard.

Perforated baskets are available

Style PC pressure cookers are offered with an optional stainless steel basket for containing products during the cooking cycle. The sturdy basket has three lifting lugs welded to a reinforcing angle ring at the top of the basket to assure easy removal. A large diameter, quick-opening door in bottom of basket permits fast, easy unloading. Baskets are carefully shaped to match contour of the kettle, having an installed clearance of approximately 2-inches between basket and kettle wall. The kettle is provided with support lugs to accurately suspend the basket at the correct clearance. Basket design is totally sanitary.

An extra-cost oil drawoff valve is another option to drain oil off the top of the kettle before removing the product. A sight glass is located at the same level to permit easy inspection. Before oil is drawn-off, water is introduced to the kettle through a special fitting to allow the oil level to rise to center of sight glass. This feature is especially recommended for meat and poultry processing.

Precision-built agitator assembly

The Hamilton PC pressure cooker can be supplied with a single motion agitator as an additional option, to provide a simple stirring motion increasing heat transfer to reduce cooking time. The entire heated kettle surface is scraped clean by removable sanitary nylon scrapers. Other options include:

- Choice of product discharge valves
- BRIGHT-ON® electropolish finish
- Choice of perforation size for baskets — 3/16-inch diameter / 3/8-inch centers; 1/2-inch diameter / 1-1/2-inch centers
- Thermometers

HAMILTON
STYLE "PC"

HAMILTON

Packaging - Processing

Bid on Equipment

1-847-683-7720

www.bid-on-equipment.com

KETTLES