

# HAMILTON STYLE "C"

Sanitary-design *tilting*  
Kettles

Standard Capacities from  
15 to 60 gallons;  
mounted on smooth  
double pedestal-type base

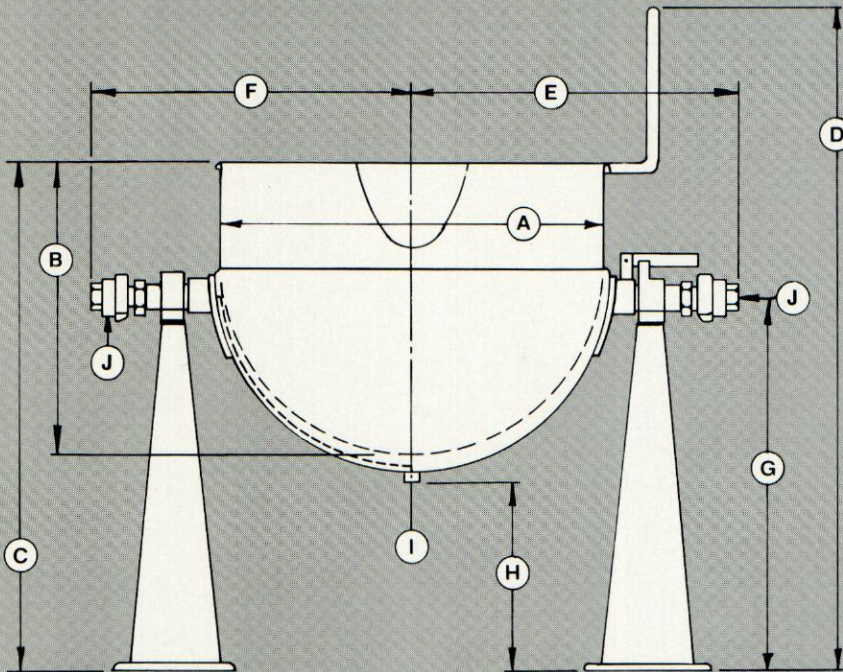

CAP. U.S. GAL.	A	B	C	D	E	F	G	H	I	J	CLEAR- ANCE UNDER LIP WHEN TILTED
15	22"	14"	33 1/4"	45 1/4"	19-1/16"	19-1/16"	27"	16 3/4"	1/2"	(2) 3/4"	18 3/4"
20	23"	16"	34 3/4"	46 3/4"	19-9/16"	19-9/16"	27"	16 1/4"	1/2"	(2) 3/4"	19 3/4"
30	25"	18 1/2"	37 1/4"	49 1/4"	20-9/16"	20-9/16"	27"	16 1/4"	1/2"	(2) 3/4"	21 1/4"
50	30"	22 1/2"	38 3/4"	50 3/4"	23-1/16"	23-1/16"	27"	13 3/4"	1/2"	(2) 3/4"	19 3/4"
60	32"	24"	39 1/4"	51 1/4"	24-1/16"	24-1/16"	27"	12 3/4"	1/2"	(2) 3/4"	19 1/4"

### Custom-crafted from standard components

The Style C Kettle is a tilting-pouring design with stream-lined balloon-type 2/3 jacket. This kind of kettle with its extra-large diameter assures maximum area for efficient heating and/or effective cooling. Style C Kettles are especially designed for fast, even cooking of heavy viscous materials. Extra-large pouring lip and economical positive locking handle tilting device permit easy pouring of any volume without spilling. Sanitary construction ensures easy cleaning and highest product purity. Kettles and jackets are fabricated of Type #304 stainless steel as standard, with Type #316 stainless steel, Nickel and Monel metal as other available materials. Each unit has heavy construction for pressures of 40, 90, 125 psi. Units are finished inside to a satin polish, outside to a semi-deluxe buff.

Pressure zone metal thickness conforms to manufacturer's standards or latest ASME Code. ASME approved steam safety valves are provided.

All five Style C Kettles are mounted on smooth double pedestal type base as shown.

Other options, accessories and extras include:

- Thermometer Connection and Guard
- Product Outlet Valves
- Various Style Covers
- BRIGHT-ON® Electropolish Finish

Specifications and dimensions shown are standard and correct at the time of printing. They may be modified to coincide with specific customer requirements. The company reserves the right to change or alter specifications and designs or to discontinue manufacture without notice or without incurring obligation.

HAMILTON  
STYLE "C"

## HAMILTON

*Packaging – Processing*

### Bid on Equipment

1-847-683-7720

[www.bid-on-equipment.com](http://www.bid-on-equipment.com)

## KETTLES