

OPERATOR MANUAL

Part Number 137770 Rev. E

OM-TDH

DOMESTIC

Models: TDH and TDHC
Steam Jacketed Kettle

*Self-contained
Gas heated
Table Top Mounted
Crank-Tilting*



Model TDH



Model TDHC



THIS MANUAL MUST BE RETAINED FOR FUTURE REFERENCE. READ, UNDERSTAND AND FOLLOW THE INSTRUCTIONS AND WARNINGS CONTAINED IN THIS MANUAL.

FOR YOUR SAFETY

DO NOT STORE OR USE GASOLINE OR OTHER FLAMMABLE VAPORS AND LIQUIDS IN THE VICINITY OF THIS OR ANY OTHER APPLIANCE.

POST IN A PROMINENT LOCATION

INSTRUCTIONS TO BE FOLLOWED IN THE EVENT USER SMELLS GAS. THIS INFORMATION SHALL BE OBTAINED BY CONSULTING YOUR LOCAL GAS SUPPLIER. AS A MINIMUM, TURN OFF THE GAS AND CALL YOUR GAS COMPANY AND YOUR AUTHORIZED SERVICE AGENT. EVACUATE ALL PERSONNEL FROM THE AREA.

WARNING

IMPROPER INSTALLATION, ADJUSTMENT, ALTERATION, SERVICE OR MAINTENANCE CAN CAUSE PROPERTY DAMAGE, INJURY OR DEATH. READ THE INSTALLATION, OPERATING AND MAINTENANCE INSTRUCTIONS THOROUGHLY BEFORE INSTALLING OR SERVICING THIS EQUIPMENT.



Packaging - Processing

Bid on Equipment

1-847-683-7720

www.bid-on-equipment.com

IMPORTANT — READ FIRST — IMPORTANT

- WARNING:** FAILURE TO DISCONNECT POWER BEFORE SERVICING COULD RESULT IN ELECTROCUTION AND DEATH.
- WARNING:** IMPROPER INSTALLATION, ADJUSTMENT, ALTERATION, SERVICE OR MAINTENANCE CAN CAUSE PROPERTY DAMAGE, INJURY OR DEATH. READ THE INSTALLATION, OPERATING AND MAINTENANCE INSTRUCTIONS THOROUGHLY BEFORE INSTALLING OR SERVICING THIS EQUIPMENT.
- WARNING:** THE UNIT MUST BE INSTALLED BY PERSONNEL QUALIFIED TO WORK WITH GAS, ELECTRICITY AND PLUMBING. UNIT MUST BE INSTALLED IN ACCORDANCE WITH ALL APPLICABLE CODES.
- WARNING:** DO NOT ATTACH THE UNIT TO A TYPE "B" VENT. IT COULD CAUSE FIRE OR PROPERTY DAMAGE.
- WARNING:** DO NOT CONNECT ANY PIPING TO THE PRESSURE RELIEF VALVE. IT MUST BE FREE TO VENT STEAM AS NEEDED. TO AVOID BURNS FROM THE VENTED STEAM THE VALVE DISCHARGE SHOULD POINT DOWNWARD.
- DANGER:** ELECTRICALLY GROUND THE UNIT AT THE TERMINAL PROVIDED. FAILURE TO GROUND THE UNIT COULD RESULT IN ELECTROCUTION AND DEATH.
- CAUTION:** BE SURE ALL OPERATORS READ, UNDERSTAND AND FOLLOW THE OPERATING INSTRUCTIONS, CAUTIONS AND SAFETY INSTRUCTIONS CONTAINED IN THIS MANUAL.
- CAUTION:** DO NOT OVERFILL THE KETTLE WHEN COOKING, HOLDING OR CLEANING. KEEP LIQUIDS A MINIMUM OF 2-3" (5-8 CM) BELOW THE KETTLE BODY RIM TO ALLOW CLEARANCE FOR STIRRING, BOILING AND SAFE TRANSFER OF PRODUCT.
- CAUTION:** KEEP FLOORS IN FRONT OF KETTLE WORK AREA CLEAN AND DRY. IF SPILLS OCCUR, CLEAN IMMEDIATELY TO AVOID SLIPS OR FALLS.
- WARNING:** KEEP WATER AND SOLUTIONS OUT OF CONTROLS AND BURNERS. NEVER USE A HIGH PRESSURE HOSE TO CLEAN KETTLE SURFACES.
- CAUTION:** MOST CLEANERS ARE HARMFUL TO THE SKIN, EYES, MUCOUS MEMBRANES AND CLOTHING. TAKE PRECAUTIONS: WEAR RUBBER GLOVES, GOGGLES OR FACE SHIELD AND PROTECTIVE CLOTHING. CAREFULLY READ WARNINGS AND FOLLOW DIRECTIONS ON CLEANER LABELS .
- WARNING:** DO NOT STAND ON OR APPLY UNNECESSARY WEIGHT OR PRESSURE ON THE KETTLE FRONT OR POURING LIP. THIS COULD RESULT IN THE OVERLOAD AND FAILURE OF THE TILT MECHANISM, AND POSSIBLE SERIOUS INJURY AND BURNS TO THE OPERATOR AND OTHERS.
- NOTICE:** NEVER LEAVE A SANITIZER IN CONTACT WITH STAINLESS STEEL SURFACES LONGER THAN 10 MINUTES. LONGER CONTACT CAN CAUSE CORROSION.
- WARNING:** FAILURE TO PERIODICALLY CHECK PRESSURE RELIEF VALVE OPERATION COULD RESULT IN PERSONAL INJURY AND/OR DAMAGE TO EQUIPMENT.
- WARNING:** WHEN TESTING, AVOID EXPOSURE TO THE STEAM BLOWING OUT OF THE PRESSURE RELIEF VALVE. DIRECT CONTACT COULD RESULT IN SEVERE BURNS.
- WARNING:** TO AVOID INJURY, READ AND FOLLOW ALL PRECAUTIONS STATED ON THE LABEL OF THE WATER TREATMENT COMPOUND.
- WARNING:** BEFORE REPLACING ANY PARTS, DISCONNECT THE UNIT FROM THE ELECTRIC POWER SUPPLY AND CLOSE THE MAIN GAS VALVE. ALLOW FIVE MINUTES FOR GAS TO VENT.
- CAUTION:** USE OF ANY REPLACEMENT PARTS OTHER THAN THOSE SUPPLIED BY GROEN OR AUTHORIZED DISTRIBUTORS CAN CAUSE INJURY TO THE OPERATOR AND DAMAGE TO THE EQUIPMENT AND WILL VOID ALL WARRANTIES.
- WARNING:** KEEP AREA AROUND KETTLE FREE AND CLEAR OF ALL COMBUSTIBLE MATERIALS. FAILURE TO DO SO COULD RESULT IN FIRE OR PROPERTY DAMAGE.
- CAUTION:** HEATING AN EMPTY KETTLE MAY CAUSE THE RELEASE OF STEAM FROM THE PRESSURE RELIEF VALVE.
- IMPORTANT:** SERVICE PERFORMED BY OTHER THAN FACTORY AUTHORIZED PERSONNEL WILL VOID ALL WARRANTIES.

Table of Contents

IMPORTANT OPERATOR WARNINGS 2
EQUIPMENT DESCRIPTION 4
INSPECTION & UNPACKING 5
INSTALLATION & INITIAL START-UP 6
OPERATION 8
CLEANING 11
SEQUENCE OF OPERATION 12
MAINTENANCE 13
COMPONENT REPLACEMENT 15
TROUBLESHOOTING 18
PARTS LISTS 20
SCHEMATIC 32
SERVICE LOG 33
REFERENCES 34

Equipment Description

Groen Models TDHC and TDH are stainless steel, steam-jacketed, table top mounted kettles with a self-contained, gas heated steam source. The TDHC has a crank tilt hand wheel, and the TDH has a handle that allows the operator to manually tilt the kettle. The kettle body is welded into one solid piece and furnished with a reinforced rim and welded-in "butterfly" shaped pouring lip. The interior of the kettle is polished to a 180 emery grit finish, and the exterior is given a bright high buff finish. The unit is A.S.M.E. shop inspected and registered with the National Board for a design pressure of 50 PSIG.

The self-contained steam source is heated by propane or natural gas and is equipped with electronic ignition. Charged at the factory with chemically pure water containing rust inhibitors, the steam source provides kettle temperatures of 150°F to approximately 295°F.

Controls for the TDHC unit include a crank tilt handwheel, thermostat, pressure gauge, pressure relief valve, low water cut-off, On/Off switch, indicator lamp, gas regulator valve, and water level sight glass. Controls for the TDH are the same as the above, with the exception of the crank tilt hand wheel.

The gas supply shuts off automatically when the kettle is tilted.

The unit must be specified for use with natural gas or propane. For other gas types, consult factory. Service connections are required for gas and 115V electricity.

Firing Rate, BTU / Hour	
TDHC-20, TDH-20	TDHC-40, TDH-40
31,000 BTU/hr	52,000 BTU/hr

KETTLE CHARACTERISTICS

Dimensions						
Model	Kettle Capacity	Jacket Capacity	Kettle Body Diameter	Kettle Body Depth	Base Width	Base Depth
TDH-20 TDHC-20	20 Qt 18.9 ℓ	6 Qt 5.7 ℓ	14" 356 mm	11" 279 mm	28" 711 mm	24" 610 mm
TDH-40 TDHC-40	40 Qt. 37.8 ℓ	12 Qt 11.4 ℓ	16½ 419 mm	14½" 362 mm	28" 711 mm	26¾" 679 mm

Options available include:

- | | |
|--|--|
| <ol style="list-style-type: none"> 1. One-piece, Lift-off cover
(P/N 128003, 20 gallon
P/N 128002 40 gallon) 2. Holder for Lift-off Cover (P/N 133837) 3. Basket insert
(P/N 001159, 20 gallon
P/N 001161, 40 gallon) | <ol style="list-style-type: none"> 4. Rice Strainer
(P/N 005187, 20 gallon
P/N 005186, 40 gallon) 5. Stand that supports the unit and holds a pan in position for filling (Model TS-9) 6. Water fill swing faucet 7. 316 stainless steel interior
(must be indicated on initial order) |
|--|--|

Inspection & Unpacking

The unit arrives completely assembled, except for the tilting handle on TDH models which is shipped inside the kettle. The unit is strapped on a skid and in a heavy carton. Inspect the carton carefully for damage. Open the container and check the unit for hidden damage. Report shipping damage or shipment errors to the delivery agent.

CAUTION

SHIPPING STRAPS ARE UNDER TENSION AND CAN SNAP BACK WHEN CUT. TAKE CARE TO AVOID PERSONAL INJURY OR DAMAGE TO THE UNIT BY STAPLES LEFT IN THE WALLS OF THE CARTON.

Write down the model number, serial number, and installation date for your unit at the top of the Service Log on Page 30. Keep this manual with the unit.

CAUTION

UNIT WEIGHS FROM 215 LBS. (98 KG) TO 240 LBS. (109 KG). INSTALLER SHOULD OBTAIN HELP AS NEEDED TO LIFT THIS WEIGHT SAFELY.

To remove the kettle from the box, cut any straps from around the box. Detach the box sides from the skid. Pull the box up off the unit, taking care to avoid damage or injury from any staples left in the box walls. When installation is to begin, cut the straps holding the kettle on the skid, and lift the kettle straight up off the skid. Examine the packing materials to make sure no loose parts are discarded with the materials. On TDH models, the tilting handle may be screwed into its socket. Attach handle to the kettle on left side or right side as shown below.



The TDH and TDHC are shipped from the factory strapped on a pallet.

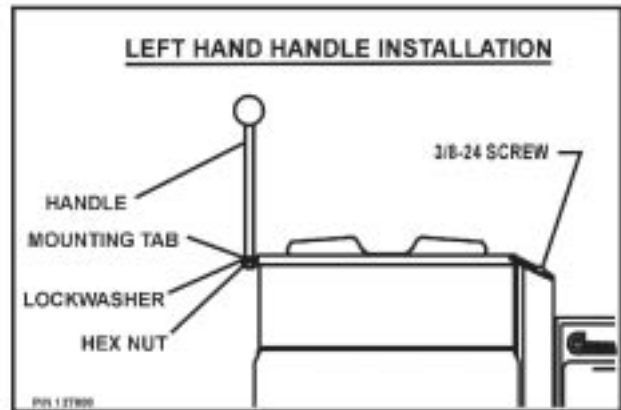

WARNING
THE KETTLE MUST BE INSTALLED BY PERSONNEL QUALIFIED TO WORK WITH GAS, ELECTRICITY AND PLUMBING. IMPROPER INSTALLATION CAN CAUSE INJURY TO PERSONNEL AND/OR DAMAGE TO THE EQUIPMENT.

Installation and Initial Start-Up

A. Installation

The TDHC kettle should be installed in a ventilated room for efficient performance. Items which might obstruct or restrict the flow of air for combustion and ventilation must be removed. The area directly around the appliance must be cleared of any combustible material.

1. Installation on combustible floors is allowed. Minimum clearances between the unit and combustible surfaces is as follows:

	Minimum distance from combustible walls	Recommended
Left Side	1"	1"
Right Side	0"	12" - 16" (for servicing)
Rear	1"	3" (for faucet bracket)

2. Groen recommends installation of the unit under a vent hood. The base must be fastened to a working surface or Groen Model TS-9 stand.
3. Complete the piping to the gas service main using ½ inch IPS pipe or an approved equivalent.

WARNING
THIS UNIT IS FOR COMMERCIAL USE. DO NOT USE HOME OR RESIDENTIAL GRADE GAS CONNECTIONS. THEY DO NOT MEET GAS CODES AND COULD BE HAZARDOUS.

4. Provide 115 VAC, 60 cycle, 1 phase, 1 AMP electric service. Local codes and/or The National Electrical Code should be observed in accordance with ANSI/NFPA-70 latest edition. AN ELECTRICAL GROUND IS REQUIRED. The electrical schematic is located on the inside of the service panel and in this manual.
5. Electrical connection to the unit must be water resistant sealtite conduit type or equal and utilize the water resistant conduit fitting provided on the unit.

6. The installation must conform with local codes or the American National Standards Z223.1 - latest edition National Fuel Gas Code. The kettle should be installed in an adequately ventilated room with provision for adequate air supply. The best ventilation will employ a vent hood and exhaust fan with no direct connection between the vent duct and the kettle flue. DO NOT obstruct the flue or vent duct after installation.

7. PRESSURE TEST WARNING

- a) Test pressure exceeding ½ PSIG (3.45 kPa). During pressure testing of the gas supply piping system at pressures **exceeding** ½ PSIG, the appliance and its individual shutoff valve must be **disconnected** from the gas supply piping system.
- b) Test pressure equal to or less than ½ PSIG (3.45 kPa). During pressure testing of the gas supply piping system at pressures **equal to or less than** ½ PSIG, the kettle must be **isolated** from the gas supply piping system by closing its individual manual shutoff valve.

8. Adequate space for proper servicing and operation is required. DO NOT block any air intake spacings to the combustion chamber or obstruct air flow.
9. After the kettle has been connected to the gas supply, check all gas joints for leaks. A soap solution or other suitable gas leak detector should be used. **Do not use flame when checking for leaks.**
10. Once the unit is anchored to a mounting surface, apply a small bead of silicone caulk around the perimeter of the kettle base and seal the joint.
11. Make sure the water level is correct in the jacket, by confirming that the level is near the middle of the sight glass. If the water level is low, follow the instructions in *Jacket Filling and Water Treatment* in the Maintenance section of this manual.
12. Check to be sure that the open end of the elbow on the outlet of the pressure relief valve is directed downward. Be sure to read and follow the instructions on the attached pressure relief valve tag.

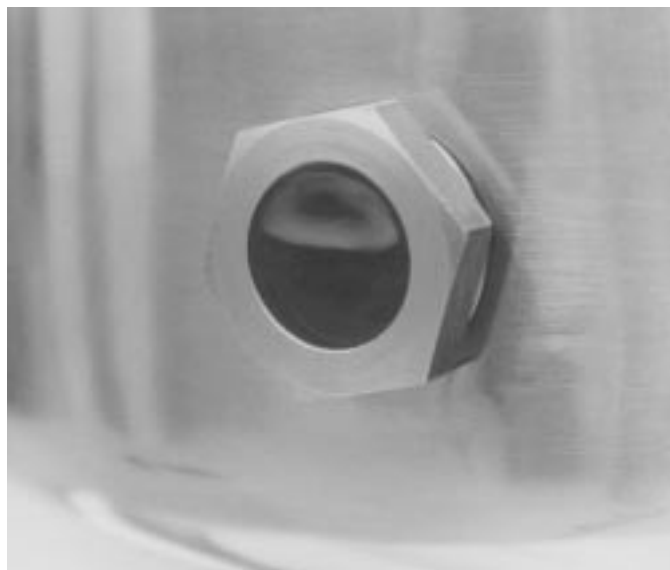

Correct Water Level

B. Initial Start-Up

IMPORTANT:
BE SURE ALL OPERATORS READ, UNDERSTAND AND FOLLOW THE OPERATING INSTRUCTIONS, CAUTIONS, AND SAFETY INSTRUCTIONS CONTAINED IN THIS MANUAL.

After the kettle has been installed, the installer should test to ensure that it is operating correctly.

1. Remove literature and packing materials from inside and outside of the unit.
2. Add water to the kettle to a depth of at least one inch.
3. Make sure the supplies of gas and electric power are on.
4. Follow the “*To Start Kettle Heating*” instructions in the Operation section of this manual. Begin heating the water at the highest thermostat setting. The indicator light should come on and heating should continue until the water boils.

5. To turn off the unit, follow “*To Stop Kettle Heating*” in the *Operation* Section of this manual.

If the kettle functions as described, it is ready for use. If the unit does not operate as designed, contact an authorized Groen Service Agent.

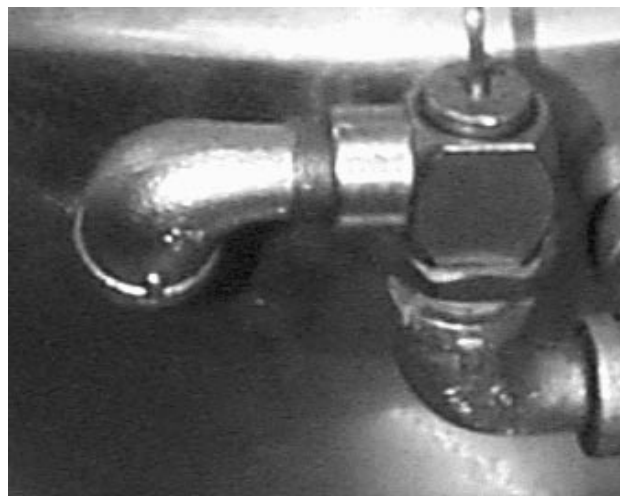

Make sure that the open end of the elbow on the pressure relief valve is directed downward.

WARNING

DO NOT STAND ON OR APPLY UNNECESSARY WEIGHT OR PRESSURE ON THE KETTLE FRONT OR POURING LIP. THIS COULD RESULT IN THE OVERLOAD AND FAILURE OF THE TILT MECHANISM, AND POSSIBLE SERIOUS INJURY AND BURNS TO THE OPERATOR AND OTHERS.

Operation

WARNING
ANY POTENTIAL USER OF THE EQUIPMENT MUST BE TRAINED IN SAFE AND CORRECT OPERATING PROCEDURES

A. Controls

Operator controls for the TDH and TDHC kettles are:

1. Manual gas valve which controls the supply of gas from the main to the unit.
2. On-Off (toggle) switch. This switch turns the control circuit power supply on or off.
3. Thermostat dial, which turns the thermostat on or off, and sets the kettle operating temperature.
4. Crank tilt handwheel (TDHC ONLY) which controls kettle movement.

B. Operating Instructions

WARNING
KEEP AREA AROUND KETTLE FREE AND CLEAR OF ALL COMBUSTIBLE MATERIALS. DO NOT ATTEMPT TO LIGHT ANY BURNER WITH A FLAME.

CAUTION
HEATING AN EMPTY KETTLE MAY CAUSE THE RELEASE OF STEAM FROM THE PRESSURE RELIEF VALVE.

1. To Start Kettle Heating

- a. CHECK THE WATER LEVEL IN THE JACKET EVERY DAY. The level should be in the middle of the sight glass. If the water level is low, see *Jacket Filling* in the Maintenance section of this manual.
- b. Check the pressure/vacuum gauge. If the gauge does not show 20 to 30 inches of vacuum (i.e., a reading of 20 to 30 below zero), see *Jacket Vacuum* in the Maintenance section of this manual.
- c. DO NOT attempt to light any burner with a flame.
- d. Open the main supply gas valve (handle in line with the pipe).
- e. Turn the toggle switch to ON.
- f. Turn the thermostat to the desired heat setting.

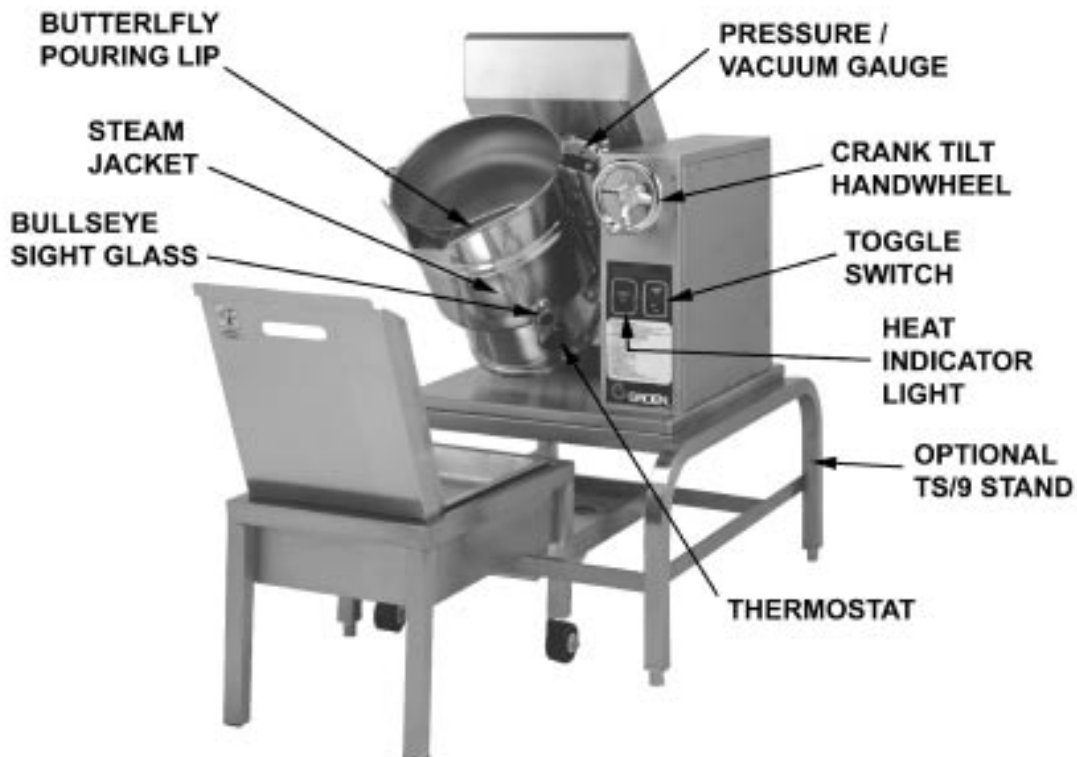

The TDHC is shown on on the optional TS/9 stand.

1. To Stop Kettle Heating

- Turn the thermostat dial to OFF.
- Turn the toggle switch OFF.
- For a prolonged shut-down:
 - Follow the procedure above.
 - Turn the manual gas valve OFF (handle at right angle to gas line).
 - Disconnect the unit's electrical power.

3. To Relight Kettle

- Close main gas supply valve.
- Set on-off switch to OFF.
- Set thermostat to OFF.
- Wait five minutes, then proceed as directed under *To Start Kettle Heating*.

4. If electric power fails, do not attempt to operate the unit. When power is restored, proceed as directed in *To Start Kettle Heating*.

5. To Transfer Product or Empty Kettle:

TDHC Kettles:

The kettle body is tilted using the crank tilt handwheel. Turning the crank clockwise tilts the kettle body; counter-clockwise returns it to an upright position. The kettle body will remain in any tilted position.

TDH Kettles:

The kettle is designed to be tilted in a controlled manner. Grasp the insulated plastic ball firmly. Maintain a firm grip on handle when tilting, keeping kettle body in a tilted position or SLOWLY returning the kettle body to an upright position.



WARNING
AVOID ALL DIRECT CONTACT WITH HOT FOOD OR WATER IN THE KETTLE. DIRECT CONTACT COULD RESULT IN SEVERE BURNS.

TAKE CARE TO AVOID CONTACT WITH HOT KETTLE BODY OR HOT PRODUCT, WHEN ADDING INGREDIENTS, STIRRING OR TRANSFERRING PRODUCT TO ANOTHER CONTAINER.

CAUTION
DO NOT OVERFILL THE KETTLE WHEN COOKING, HOLDING OR CLEANING. KEEP LIQUIDS 2-3" (5-8 cm) BELOW THE KETTLE RIM TO ALLOW CLEARANCE FOR STIRRING, BOILING PRODUCT AND SAFE TRANSFER.

WARNING
WHEN TILTING KETTLE:
1) WEAR PROTECTIVE OVEN MITT AND PROTECTIVE APRON.
2) USE DEEP CONTAINER TO CONTAIN AND MINIMIZE PRODUCT SPLASHING.
3) PLACE CONTAINER ON STABLE, FLAT SURFACE, CLOSE TO THE KETTLE.
4) STAND AWAY FROM POUR PATH OF HOT CONTENTS.
5) POUR SLOWLY, KEEP CONTROL OF KETTLE, AND RETURN KETTLE BODY SLOWLY TO UPRIGHT POSITION AFTER CONTAINER IS FILLED OR TRANSFER IS COMPLETE.
6) DO NOT OVERFILL CONTAINER. AVOID DIRECT SKIN CONTACT WITH HOT CONTAINER AND ITS CONTENTS.

6. Use of Common Accessories

Lift-Off Cover

- As with stock pot cooking, an optional lift off cover will speed up the heating of water and food products. A cover helps retain heat in the cooking vessel and reduces the amount of heat and humidity released into the kitchen. Use of a cover can reduce some product cook times and help maintain the temperature, color and texture of products being held or simmered for extended periods.
- Make sure the plastic ball handle is secure on the lift off cover before using. ALWAYS use the plastic handle to place or remove cover from the kettle. Wear protective oven mitts and a protective apron.
- When putting the cover on the kettle, position it on top of kettle rim, with its flat edge facing the pouring lip.
- When removing cover:
 - Firmly grasp plastic handle



WARNING
AVOID ALL DIRECT CONTACT WITH HOT SURFACES. DIRECT SKIN CONTACT COULD RESULT IN SEVERE BURNS.

AVOID ALL DIRECT CONTACT WITH HOT FOOD OR WATER IN THE KETTLE. DIRECT CONTACT COULD RESULT IN SEVERE BURNS.

CAUTION
DO NOT TILT KETTLE BODY WITH COVER OR BASKET INSERT IN PLACE. COVER MAY SLIDE OFF, CAUSING INJURY TO OPERATOR.

- 2) Lift rear edge (farthest from operator) 1-2" (3-5 cm) to allow any steam and water vapor to escape the cooking vessel. Wait 2-3 seconds.



Lift the rear of the lid first.

- 3) Tilt cover to 45-60° angle and allow any hot condensate or product to roll off cover back into kettle.
- 4) Remove cover, ensuring that any remaining hot condensate or product does not drip on operator, floor or work surfaces.
- 5) Place cover on safe, flat, sanitary, out-of-the-way surface, or return to kettle rim. Cover may also be placed in the optional holder (P/N 133837) for cover as shown in the photograph.



Basket Insert

- a. An optional kettle basket insert can assist in cooking water-boiled products including eggs, potatoes, vegetables, shell fish, pasta and rice. The nylon mesh liner must be used when cooking product smaller than the mesh size of the basket, which is approximately 1/4" (6 mm). This includes rice and small pasta shapes.
- b. Tips For Use.
 - 1) Allow for the water displacement of the basket and product to be cooked. This may mean only filling the kettle half full of water. Test the basket and product displacement with the kettle OFF, and with cold water in the kettle.

CAUTION
DO NOT OVERFILL THE KETTLE WHEN COOKING, HOLDING OR CLEANING. KEEP LIQUIDS A MINIMUM OF 2-3" (5-8 cm) BELOW THE RIM TO ALLOW FOR STIRRING, BOILING AND SAFE PRODUCT TRANSFER.

- 2) Load basket on a level, stable work surface.
- 3) Lift the loaded basket with both hands. Get help from another person if the basket is too heavy for safe handling. Then slowly lower product into kettle.
- 4) When removing basket with cooked product, lift basket straight up, ensuring bottom of basket clears the rim and pouring lip of the kettle. Wear protective oven mitts and protective apron.
- 5) Allow hot water to fully drain from product, before moving basket away from the kettle. Do not rest kettle basket on kettle rim or pouring lip. If basket is too heavy for individual to lift and safely move, get help from another person. Remove product immediately from basket into another container, being sure to avoid contact with hot product and hot basket **or** place basket with food on stable, flat surface, setting it inside a solid steamer or bake pan, to catch any remaining hot water draining from product.

Cleaning

1. Suggested Cleaning Supplies:

- a. Cleaner, such as Klenzade HC-10 or HC-32 from ECOLAB, Inc.
- b. Kettle brushes in good condition.
- c. Sanitizer such as Klenzade XY-12.
- d. Film remover such as Klenzade LC

2. Precautions

Before any cleaning operation, shut off the kettle by turning the thermostat dial to "OFF", and shut off all electrical power to the unit at a remote switch, such as the circuit breaker.

WARNING
KEEP WATER AND SOLUTIONS OUT OF CONTROLS AND BURNERS. DO NOT USE A HIGH PRESSURE HOSE TO CLEAN THE CONTROL CONSOLE, ELECTRICAL CONNECTIONS, ETC.

3. Procedure

- a. Clean food contact surfaces as soon as possible after use, preferably while the kettle is still warm. If the unit is in continuous use, clean and sanitize inside and outside at least once every 12 hours.
- b. Scrape and flush out large amounts of food residues. Be careful not to scratch the kettle with metal implements.

CAUTION
NEVER LEAVE A CHLORINE SANITIZER IN CONTACT WITH STAINLESS STEEL SURFACES LONGER THAN 30 MINUTES. LONGER CONTACT CAN CAUSE CORROSION.



WARNING
AVOID DIRECT CONTACT WITH HOT SURFACES. DIRECT SKIN CONTACT COULD RESULT IN SEVERE BURNS.

- c. Prepare a solution of the detergent/cleaning compound as instructed by the supplier. Clean the unit thoroughly. A cloth moistened with cleaning solution can be used to clean controls, housing, electrical conduit, etc.

- d. Rinse the kettle thoroughly with hot water. Then drain completely.



CAUTION
MOST CLEANERS ARE HARMFUL TO THE SKIN, EYES, MUCOUS MEMBRANES AND CLOTHING. PRECAUTIONS SHOULD BE TAKEN TO WEAR RUBBER GLOVES, GOGGLES OR FACE SHIELD AND PROTECTIVE CLOTHING. CAREFULLY READ THE WARNINGS AND FOLLOW LABEL DIRECTIONS.

- e. As part of the daily cleaning program, clean all inside and outside surfaces that may have been soiled. Remember to check such parts as the underside of the cover, control housing, etc.



Scrapers, steel wool or metal implements will harm the kettle surface.



Use a sponge, cloth or plastic brush to clean the kettle.

OM-TDH

- f. To remove burned-on foods, use a brush, sponge, cloth, plastic or rubber scraper, or plastic wool along with the cleaning solution. To reduce effort required in washing, let the detergent solution sit in the kettle for a few minutes and soak into the residue. Do NOT use abrasive materials or metal tools that might scratch the surface. Scratches make the surface harder to clean and provide places for bacteria to grow. Do **not** use steel wool, which will leave particles in the surface and cause eventual corrosion and pitting.
 - g. The outside of the unit may be cleaned with a warm water (100°F or less) spray. **Do not use a high pressure spray.**
 - h. The outside of the unit may be polished with a recognized stainless steel cleaner like “Zepper” from Zep Manufacturing Company.
 - i. When the equipment needs to be sanitized, use a sanitizing solution equivalent to one that supplies 200 parts per million chlorine. Obtain advice on the best sanitizing agent from your supplier of sanitizing products.
- Following the supplier’s instructions, apply the sanitizing agent after the unit has been cleaned and drained. Rinse off the sanitizer thoroughly.
 - j. It is recommended that the unit be sanitized just before use.
 - k. Clean the kettle thoroughly. If there is difficulty removing mineral deposits or a film left by hard water or food residues, then use a de-liming agent, such as Groen De-limer De-Scaler (Part Number 114800), Lime- Away from ECOLAB or an equivalent, following manufacturer directions.
 - l. Rinse and drain the unit thoroughly before further use.
 - m. If especially difficult cleaning problems persist, contact your cleaning product supplier for assistance. The supplier has a trained technical staff with laboratory facilities to serve you.

Sequence of Operation

The following “action-reaction” outline is provided to help understand how the equipment works.

1. When the power switch is turned on, it starts the spark igniter and opens the automatic valve for the pilot burner. The spark ignites a pilot flame, which heats the sensor. The sensor then sends a signal to turn off the spark. The flame thereafter acts as a standing pilot until the power is turned off.
2. If the pilot flame is not sensed within 90 seconds after spark begins, a timer shuts down the entire operation. To attempt a second trial for ignition, turn off the power switch. Check the gas supply valves and wait five minutes before trying again by switching power on. If you cannot establish a pilot flame in four tries, close all valves, turn off the power, and contact an authorized Groen Service Agency.
3. When the operator sets a temperature on the thermostat, it causes the automatic valve to admit gas to the main burner, where it is ignited by the pilot flame. When the kettle reaches the set temperature, the thermostat switch opens.

This stops the signal to the gas control valve and shuts off gas to the main burner. The pilot flame remains lit. When the kettle cools below the set temperature, the thermostat switch closes and starts another cycle. On and off cycling continues and maintains the kettle at the desired temperature. This action is indicated by the Heat indicator light.

The kettle has the following safety features in addition to the 90-second ignition timer:

1. Low water cutoff relay that will shut off gas supplies to all burners until the jacket water level is corrected.
2. High limit pressure switch, set to open at about 43 PSI and to shut down the burners until jacket pressure is decreased.
3. Pop pressure relief valve, which will release steam if jacket pressure exceeds 50 PSI.
4. Tilt switch, which shuts off all burners when the kettle is tilted.
5. Gas pressure regulator built into the gas control valve.

Maintenance

NOTICE: Contact an authorized Groen Service Agent when repairs are required.

A Maintenance & Service Log is provided at the back of this manual with the warranty information. Each time maintenance is performed on your Groen kettle, enter the date on which the work was done, what was done, and who did it. Keep this manual on file and available for operators to use.

Periodic inspection will minimize equipment down time and increase the efficiency of operation. The following points should be checked:

1. Jacket Vacuum/ Removing Air From Jacket (By Operator)

Every day, while the kettle is cold, read the pressure/ vacuum gauge. A positive reading or a negative reading between zero and 20" vacuum on the pressure/ vacuum gauge indicates excess air in the jacket. Air in the jacket slows kettle heating and can prevent the kettle from reaching operating temperature. To remove air:

- Start the kettle. (See the **Operation** section).
- Make sure the elbow on the outlet of the pressure relief valve is turned so that escaping steam is directed down toward the floor (see photo on page 7).
- When the pressure/vacuum gauge reaches a positive pressure reading of 5 PSI, release trapped air by lifting the pressure relief valve ring for about one second. Repeat this step, then let the valve ring snap closed, so the valve will seat properly and not leak.



The pressure gauge should show a vacuum of 20 to 30 inches when the kettle is cold.

2. Pressure Relief Valve (By Operator)

At least twice a month, test the pressure relief valve. Test the valve with the kettle operating at 15 PSI (105 kPa), by holding the test ring for at least five seconds. Then release the ring and permit the valve to snap shut. If the ring does not activate, if there is no discharge, or if the valve leaks, stop using the kettle immediately and contact a authorized Groen service representative.

WARNING

AVOID EXPOSURE TO THE STEAM BLOWING OUT OF THE PRESSURE RELIEF VALVE. SEVERE BURNS CAN RESULT ON EXPOSED SKIN.

FAILURE TO CHECK PRESSURE RELIEF VALVE OPERATION PERIODICALLY COULD RESULT IN PERSONAL INJURY AND/OR DAMAGE TO EQUIPMENT.

3. Grease / Lubrication

For TDH Models: At least twice a year, grease the two trunnion bearings. The bearings are located within the kettle support housing. Remove the access panels from the support housing with a screwdriver to gain access to the grease fittings. Use a lithium-based, multi-purpose grease. When the access panels are removed, the mounting bolts for the trunnion bearings and tilt switch can also be checked for tightness. When finished, reassemble access panels to support housing.

For TDHC Models: The gear housing has been fitted for proper lubrication of moving parts. Since the gears do not run in oil, periodic lubrication with grease is essential. Frequency of lubrication depends on operating conditions, but should occur at least once every six months. Groen recommends the use of a Number Two grade LGI lithium grease. Add grease through the Zerk fittings on the gear housing until grease flows out of the bearings around the trunnion shaft. Place a liberal amount of grease on the gear to cover the arc that is in contact with the worm gear.

CAUTION

KEEP GREASE AWAY FROM ELECTRICAL PARTS.

4. Jacket Filling

Every day, **before you turn on the unit**, make sure the water level is approximately in the center of the water gauge glass. The jacket was filled at the factory with the proper amount of treated water, and is air-tight, but over time steam may be vented and water lost.

From time to time, you may need to restore the water to its proper level. The procedure for adding water follows.

- a. If you are replacing water lost as steam, use distilled water. **Do not use tap water.** If you are replacing treated water that was drained from the jacket, prepare more treated water as directed below.

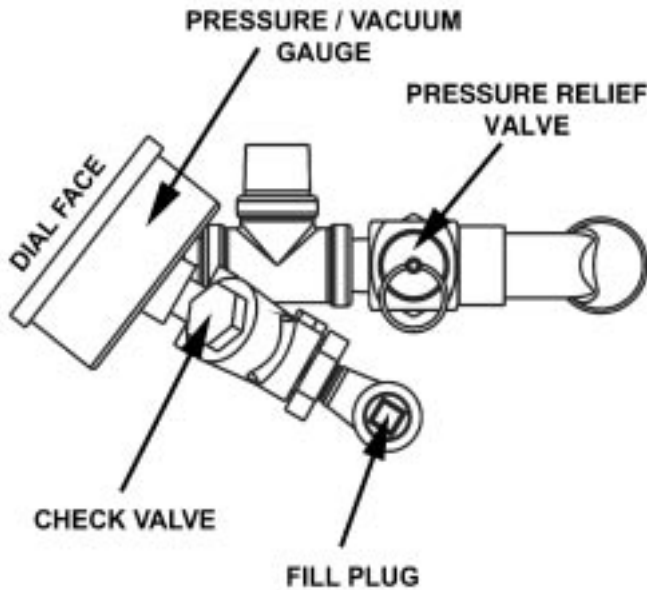

The pressure relief valve and fill plug are located directly behind the pressure/vacuum gauge.

- b. Allow the kettle to cool **completely**. Remove the pipe plug from the jacket fill assembly. Pour in the distilled or treated water. Using a funnel will help you in this process. Hold the pressure relief valve open while you pour, to let air escape from the jacket. Continue adding water until the water level rises to the center of the round sight glass.
- c. Air that gets into the jacket during the filling operation must be removed, because it will make heating less efficient. Follow the procedure in **Jacket Vacuum/Removing Air From Jacket** above, to restore a negative pressure reading.

5. Water Treatment

WARNING
TO AVOID INJURY, READ AND FOLLOW ALL PRECAUTIONS STATED ON THE LABEL OF THE WATER TREATMENT COMPOUND.

- a. Fill a mixing container with the amount of water required. Use only distilled water.

Model	Kettle Capacity	Jacket Capacity
TDH-20, TDHC-20	20 Qt 18.9 ℓ	6 Qt 5.7 ℓ
TDH-40, TDHC-40	40 Qt 37.8 ℓ	12 Qt 11.4 ℓ

- b. Hang a strip of pH test paper on the rim of the container, with about 1 inch of the strip below the surface of the water. If there is a problem distinguishing color, use a pH meter.
- c. Stir the water continuously, while you slowly add water treatment compound until a color between indicating a pH of 10.5 and 11.5 is reached. (Shown on the pH test kit chart.) Judge the pH by frequently comparing the test strip with the color chart provided in the pH test kit.
- d. Use a measuring cup to add the compound so that you may record the exact amount used.
- e. The amount may be used again, if the same water sources and compound are used in the future. However, it is best to check the pH each time treated water is prepared.

WARNING
USE OF ANY REPLACEMENT PARTS OTHER THAN THOSE SUPPLIED BY GROEN OR THEIR AUTHORIZED DISTRIBUTORS CAN CAUSE INJURY TO THE OPERATOR AND DAMAGE TO THE EQUIPMENT AND WILL VOID ALL WARRANTIES.

CAUTION
INSURE ELECTRICAL POWER IS REMOVED AND THE GAS IS TURNED OFF AT THE SHUTOFF VALVE PRIOR TO PERFORMING ANY MAINTENANCE ON THIS KETTLE.

WARNING
THIS KETTLE IS DESIGNED TO BE WATER RESISTANT. FAILURE TO FOLLOW PROPER MAINTENANCE PROCEDURES MAY VOID THE WARRANTY.

Component Replacement



WARNING
BEFORE REPLACING ANY PARTS,
DISCONNECT THE UNIT FROM THE ELECTRIC
POWER SUPPLY.

All internal wiring is marked as shown on the circuit schematic drawings. Be sure that new components are wired in the same manner as the old components.

1. Removal of right hand side cover

- a. Remove 14 phillips head screws (12 screws for the TDH-20).
- b. Remove side cover.

CAUTION
FAILURE TO INSTALL ALL 14 COVER SCREWS
MAY VOID WARRANTY.

2. Installation of right hand side cover

Install all 14 phillips head screws (12 screws for the TDH-20) to maintain water resistance of electronics compartment and torque to 10 in-lbs.

3. Removal of ON/OFF switch

- a. Remove right hand side cover (see Section #1 above).
- a. Remove black and red wires from switch.
- b. Unscrew nut from outside of switch.
- c. Remove switch from inside being careful not to lose rubber gasket.

4. Installation of ON/OFF switch

- a. Insert switch through hole in the front panel from the inside.
- b. Insure the rubber gasket is inserted between switch and front panel.
- c. Install knurled nut on switch and tighten to hand tight plus $\frac{1}{2}$ to $\frac{3}{4}$ turn.
- d. Reinstall red and black wires on switch.
- e. Reinstall right hand side cover (see Section #2 above).

NOTE: THIS KETTLE IS DESIGNED TO BE WATER RESISTANT. ALL SEALS AND GASKETS MUST BE IN PLACE AND FUNCTIONAL UPON COMPLETION OF ANY SERVICE. FAILURE TO DO SO WILL VOID THE WARRANTY.

5. Removal of burner "ON" indicator light

- a. Remove right hand side cover (see Section #1 above).
- a. Remove blue and green wires from light.
- b. Remove nut from light on inside of electrical box.
- c. Pull light out being careful not to lose rubber grommet.

6. Installation of burner "ON" indicator light

- a. Install light from outside of front panel.
- b. From inside of panel install rubber grommet then nut.
- c. Tighten nut hand tight plus $\frac{1}{2}$ to $\frac{3}{4}$ turn.
- d. Reattach blue and green wires.
- e. Reinstall right hand side cover as stated in Section #2 above.

7. Removal of transformer

- a. Remove right hand side cover (see Section #1 above).
- b. Unplug wires from transformer terminals: two red wires, one green wire, and one white wire.
- c. Remove both $\frac{1}{4}$ " mounting screws.

8. Installation of transformer

- a. Mount transformer with two $\frac{1}{4}$ " mounting screws.
- b. Install two red wires on bottom terminals, the white wire on the top right terminal and the green wire on the top left terminal.
- c. Reinstall right hand side cover as stated in Section #2 above.

9. Removal of water level control board

- a. Remove right hand side cover (see Section #1 above).
- b. Remove wires from control board.
- c. Squeeze plastic stand-offs behind board and pull board off.

10. Installation of water level control board

- a. Align control board and install two ¼" mounting screws.
- b. Install wires in the following order:
 - i. Blue wire bottom right
 - ii. Red wire second from bottom right
 - iii. Green wire upper right
 - iv. Yellow wire bottom left
 - v. Double red wire top left
- c. Reinstall right hand side cover as stated in Section #2 above.

11. To remove Honeywell gas control module

- a. Remove right hand side cover (see Section #1 above).
- b. Remove wires from module terminals.
- c. Remove the four ¼" mounting screws.

12. Installation of Honeywell gas control module

- a. Align module and install the four ¼" mounting screws.
- b. Reinstall wiring in the following order, starting on the left with terminal 1:
 - i. Red (MV)
 - ii. Yellow (MV/PV)
 - iii. Black (PV)
 - iv. Green 24v from burner
 - v. Green 24v ground
 - vi. Red 24v
 - vii. Terminal 9 Spark ignition lead
- c. Reinstall right hand side cover as stated in Section #2 above.

13. Removal of tilt micro switch

- a. Tilt kettle 90°.
- b. Remove the right hand side cover (see Section #1 above).
- c. Remove blue and white wires from switch.
- d. Remove the two mounting screws.
- e. Remove switch.

14. Installation of tilt micro switch

- a. Tilt kettle 90°.
- b. Align switch with mounting holes behind bracket with paddle facing forward.
- c. Install both mounting screws and nuts.
- d. Replace both the blue and white wires on the bottom two tabs.
- e. Insure kettle actuates switch when it is returned to the upright position.

- f. Reinstall right hand side cover as stated in Section #2 above.

15. Removal of gas valve

- a. Turn off gas supply to the kettle.
- b. Remove side cover (see #1 above).
- c. Disconnect electrical power from the kettle.
- d. Disconnect wiring from the gas valve.
- e. Disconnect valve to burner tube using a ½" in-line wrench.
- f. Remove 90° elbow.
- g. Remove burner cover by removing three screws on cover flange and two hex head bolts located inside electrical box.
- h. Disconnect union on gas piping located under burner cover.
- i. Remove gas valve.

16. Installation of gas valve

- a. Remove piping from old valve and install on new valve.
- b. Reconnect the union under burner cover.
- c. Reinstall burner cover.
- d. Reinstall gas piping removed in step 19.
- e. Insure rubber grommet is properly installed.
- f. Reconnect electrical wiring in the following order:
 - i. Black to PV
 - ii. Yellow to MV-PV
 - iii. Blue to MV (TH)
- g. Reinstall right hand side cover as stated in Section #2 above.

17. Removal of thermostat

- a. Remove thermostat knob by pulling straight out.
- b. Remove the two mounting screws.
- c. Remove thermostat shroud.
- d. Tilt kettle to 90°.
- e. Remove bottom cover.
- f. Remove blue and red wires from thermostat.
- g. Unscrew temperature bulb from kettle body being careful not to damage adjacent pressure switch.

18. Installation of thermostat

- a. Tilt kettle 90°.
- b. Install thermostat gasket in opening in skirt.
- c. Install second gasket on thermostat and align the screw holes with the holes in the gasket.
- d. Place the thermostat through the hole in the kettle skirt and align screw holes.
- e. Replace plastic spacer on thermostat shaft.

- f. Replace the stainless knob shroud and align holes.
- g. Start both screws but do not tighten.
- h. Put Teflon tape on the screw threads of the thermostat bulb and insert into bottom of kettle. Tighten hand tight plus one turn.
- i. Install bottom cover on skirt. Tighten screws and gasket to 10-12 in-lb torque.
- j. Turn the kettle upright and tighten the two thermostat mounting screws.
- k. Install knob by pushing straight on shaft.
- l. If the knob appears loose, remove and gently spread the two prongs of the shaft and reinstall knob.
- m. Check water level.
- n. Remove air from jacket.

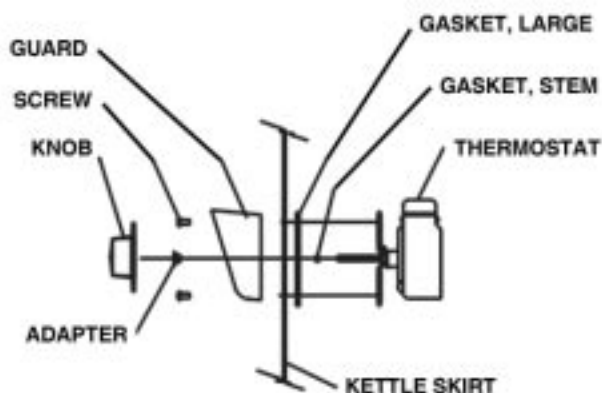

Thermostat and Gasket Installation Detail

19. Removal of water level probe

- a. Tilt kettle 90° and remove bottom cover.
- b. Remove yellow wire from probe.
- c. Unscrew probe from kettle jacket.

20. Installation of water probe

- a. Apply Teflon tape to probe threads.
- b. Screw probe into kettle jacket and torque to 150 in-lbs.
- c. Attach yellow wire to probe.
- d. Reinstall bottom cover.
- e. Check water level.
- f. Remove air from jacket.

21. Removal of pressure switch

- a. Tilt kettle a full 90°.
- b. Remove bottom cover.
- c. Unplug red and white wires from switch.
- d. Using a 9/16 open end wrench, carefully unscrew the pressure switch from the 90° elbow.

22. Installation of pressure switch

- a. Hand start the pressure switch into the 90° elbow.
- b. Using a 9/16 wrench, tighten the switch to 90 in-lbs.
- c. Reattach the red and white wires to the switch.
- d. Reinstall bottom cover.
- e. Check water level.
- f. Remove air from jacket.

Troubleshooting

Your Groen kettle is designed to operate smoothly and efficiently if properly maintained. However, the following is a list of checks to make in the event of a problem. Wiring diagrams are furnished inside the service panel and in this manual. **If an item on the list is followed by ✕, the work should be done by a qualified service representative.**

WARNING		
BEFORE REPLACING ANY PARTS, DISCONNECT THE UNIT FROM THE ELECTRIC POWER SUPPLY AND CLOSE THE MAIN GAS VALVE. ALLOW FIVE MINUTES FOR UNBURNED GAS TO VENT.		
CAUTION		
USE OF ANY REPLACEMENT PARTS OTHER THAN THOSE SUPPLIED BY GROEN OR THEIR AUTHORIZED DISTRIBUTOR CAN CAUSE INJURY TO THE OPERATOR AND DAMAGE TO THE EQUIPMENT AND WILL VOID ALL WARRANTIES.		
SYMPTOM	WHO	WHAT TO CHECK <small>✕ indicates items which must be performed by an authorized technician.</small>
Kettle is hard to tilt. (TDHC ONLY).	Auth Service Rep Only	a. Gears for foreign materials, and lubrication. ✕ b. Gears for alignment. ✕ c. Worm gears or broken gears. ✕
Kettle continues heating after it reaches desired temperature.	User	a. Thermostat dial setting.
	Auth Service Rep Only	b. Thermostat calibration. ✕ c. Thermostat operation. The thermostat should click when the dial is rotated to settings above and below the temperature of the kettle. ✕
Kettle stops heating before it reaches the desired temperature.	User	a. Thermostat dial setting.
	Auth Service Rep Only	b. Thermostat calibration. ✕ c. Thermostat operation. The thermostat should click when the dial is rotated to settings above and below the temperature of the kettle. ✕
Pressure Relief Valve pops open	User	a. For air in the jacket. See Jacket Vacuum / Removing Air From Jacket in the Maintenance section. b. Thermostat dial setting.
	Auth Service Rep Only	c. For defective thermostat. The thermostat should click when the dial is rotated to settings above and below the temperature of the kettle. If defective, replace. ✕ d. For defective pressure relief valve. If the valve pops at pressures below 49 PSI, replace. ✕
Burners will not light.	User	a. That the main gas supply valve is open. (handle is in line with gas pipe). b. Gas supply to the building. c. That the kettle body is horizontal.
	Auth Service Rep Only	d. Thermostat operation. The thermostat should click when the dial is rotated to settings above and below the temperature of the kettle. ✕ e. Momentary switch is being properly actuated. ✕
System does not produce a spark	Auth Service Rep Only	a. Thermostat, and close the contacts if they are open ✕ b. AC voltage between terminals on secondary side of transformer. If it is not 24 Volt, replace the transformer ✕ c. That the high tension cable is firmly attached and in good condition. If cracked or brittle, replace. ✕ d. Pilot electric ceramic for crack or break. ✕ e. Pilot spark gap. Regap. ✕

SYMPTOM	WHO	WHAT TO CHECK ✘ indicates items which must be performed by an authorized technician.
Spark is present but the pilot will not light.	Auth Service Rep Only	a. That the pilot valve is securely connected to terminals.✘ b. For 24 VAC at terminals PV and PV/MV. If 24V is not present, replace the ignition control module.✘ b. That gas pressure is at least 3.5" W.C.(8.7818 μb).✘ c. For gas at the pilot. If it is not flowing: (1) Check the pilot gas line for kinks and obstructions.✘ (2) Clean orifice, if necessary.✘ (3) Check magnetic operator for pilot valve on gas valve. Repair or replace as necessary.✘ d. That the pilot spark gap is located in the pilot gas stream. If not, adjust or replace the pilot burner.✘ e. For drafts. Shield the pilot burner, if necessary.✘
Pilot lights, but main burner will not come on and spark does not stay on.	Auth Service Rep Only	a. For 24 V between terminals PV and PV/MV. If 24V is not present, replace the ignition control module.✘ b. That gas pressure is at least 3.5" W.C.(8.7818 μb).✘ c. Electrical connections of the main valve to terminals, to assure that they are securely attached. Check magnetic operator for pilot valve on gas valve. Repair or replace as necessary.✘
Pilot lights, but main burner will not come on, the spark stays on.	Auth Service Rep Only	a. Check for bad burner ground. If necessary, repair with high temperature wire.✘ b. Pilot burner ceramic insulator for cracks.✘ c. That cable is not grounded out. If it is, correct the ground-out condition or replace cable.✘ d. For proper gas pressure.✘ e. Clean pilot assembly, or replace if necessary.✘ f. Tighten all mechanical and electrical connections.✘ g. If the pilot flame is weak, increase pilot orifice size.✘ h. Replace ignition control module.✘
Main burner comes on but will not stay on.	Auth Service Rep Only	a. Check burner ground for bad wire or connection. Replace if necessary with high temperature wire.✘ b. Check for low gas supply pressure. If necessary, replace ignition control module.✘

Parts List

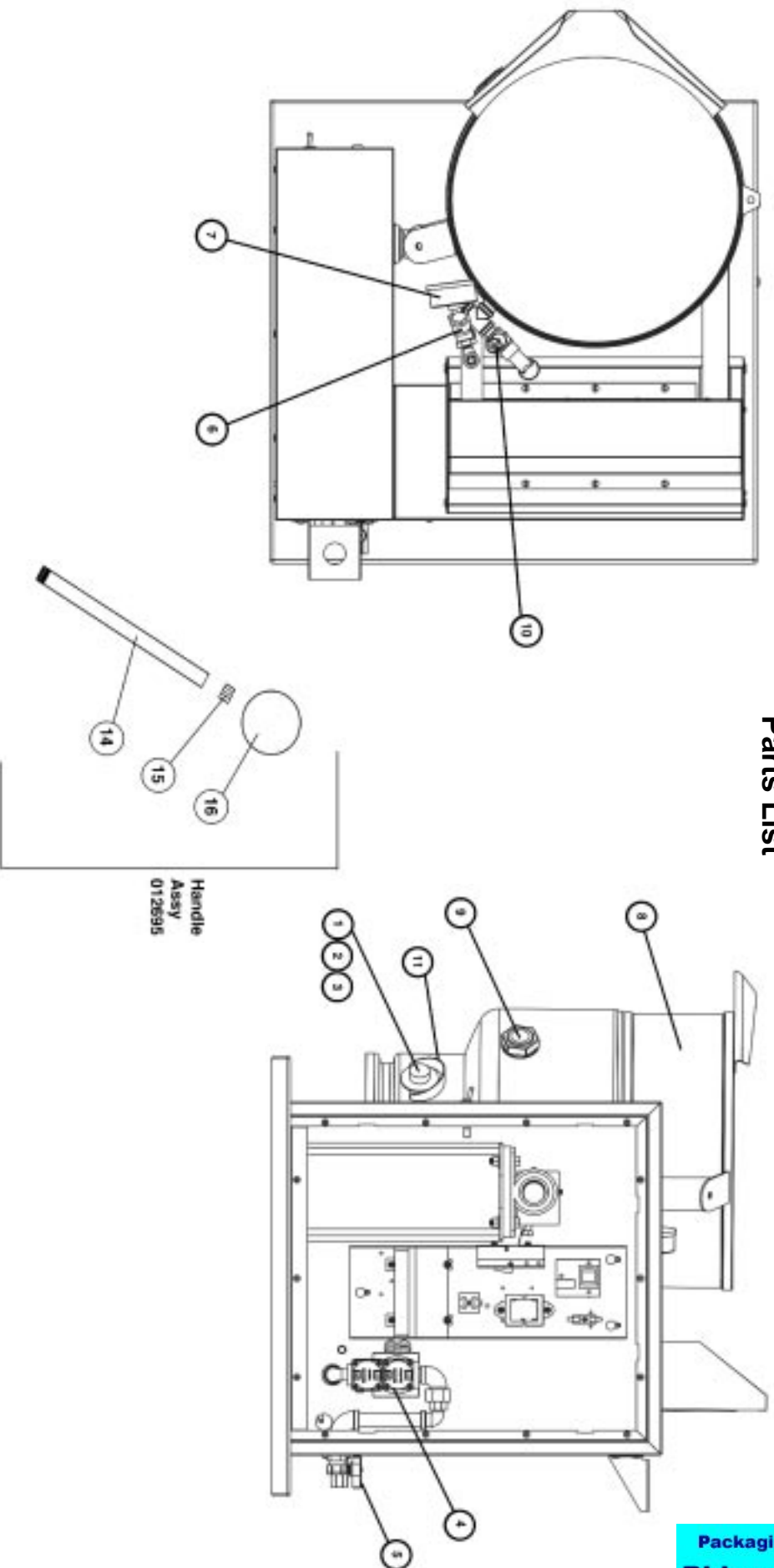

To order parts, contact your Groen Authorized Service Agency. Supply the model designation, part description, part number, quantity, and where applicable, voltage.

Key	Description	Part No.	Key	Description	Part No.	Key	Description	Part No.
1	Knob, Thermostat	002868	7	Gauge	084208	12	Switch, Pressure (Not Shown)	096963
2	Gasket, Thermostat	123585	8	Kettle Body Assy	137733	13	Electrode, Water Level (Not Shown)	074623
3	Thermostat	012313	9	Glass, Site Round	108554	14	Shaft, Handle	018963
4	Gas Valve, Nat. Gas	098443	10	Valve, Pressure Relief 50 PSI	097005	15	Ring, 1/2"	012692
5	Gas Valve, Manual Shut Off	098458	11	Guard, Thermostat	114830	16	Ball, Red	012691
6	Valve, 1/4" Swing, Check	096915						

Parts List

To order parts, contact your Groen Authorized Service Agency. Supply the model designation, part description, part number, quantity, and, where applicable, voltage.

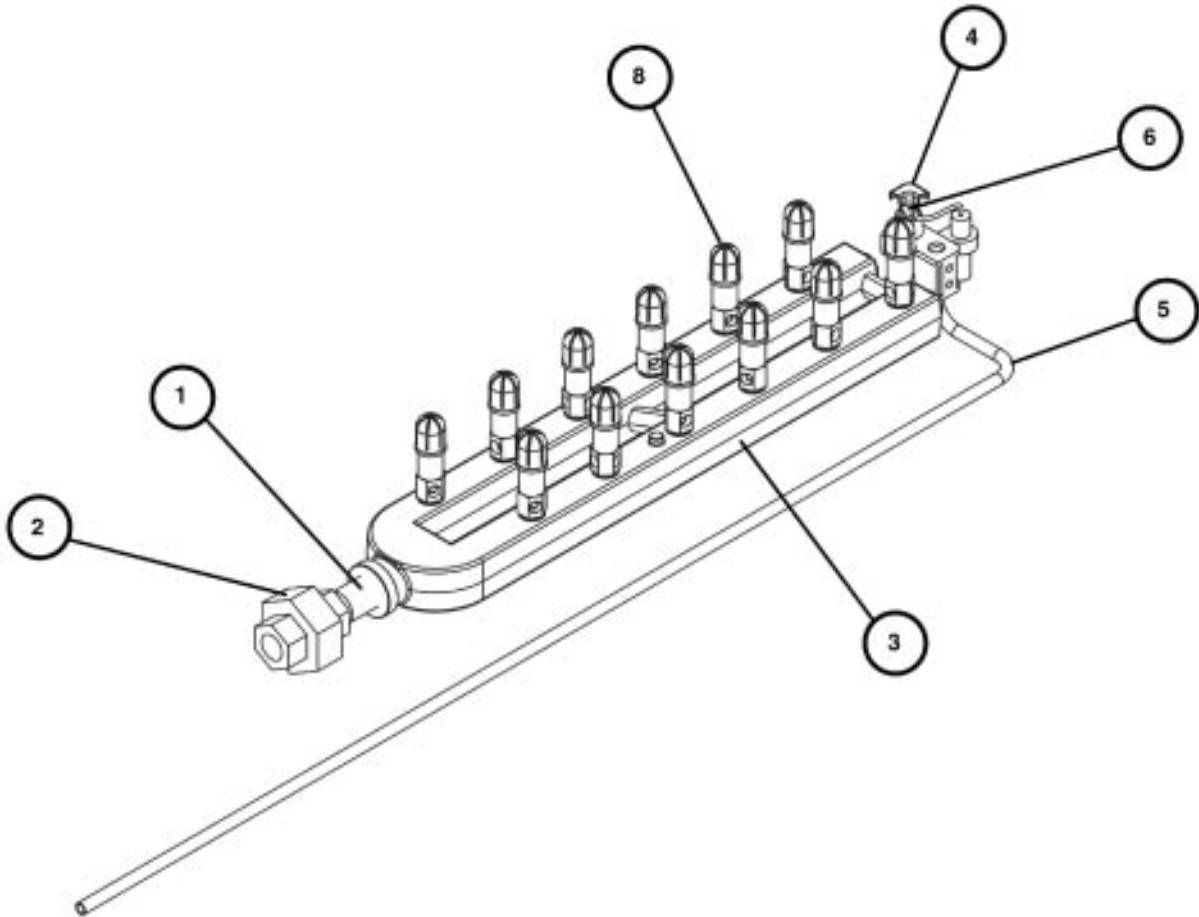

Key	Description	Part No.	Key	Description	Part No.
1	Nipple, 3/8" NPT x 2"	005679	5	Tube, Pilot	135487
2	Union, 3/8" NPT	005686	6	Pilot Orifice Spud Natural Gas	098648
3	Manifold, TDH-20	137757	6	Pilot Orifice Spud Propane Gas	098647
	Manifold, TDH-40	137056	7	Fitting, Compression 90 (Not Shown)	004584
4	Pilot	097024	8	Orifice SEE TABLE BELOW	

PART # 8	# of Orifices	Natural Gas	Propane Gas	Altitude
TDH-20 TDHC-20	8	137758	137756	0 - 2000 ft
TDH-40 TDHC-40	12	135543	137756	0 - 2000 ft

Parts List TDH Units Only

To order parts, contact your Groen Authorized Service Agency. Supply the model designation, part description, part number, quantity, and, where applicable, voltage.

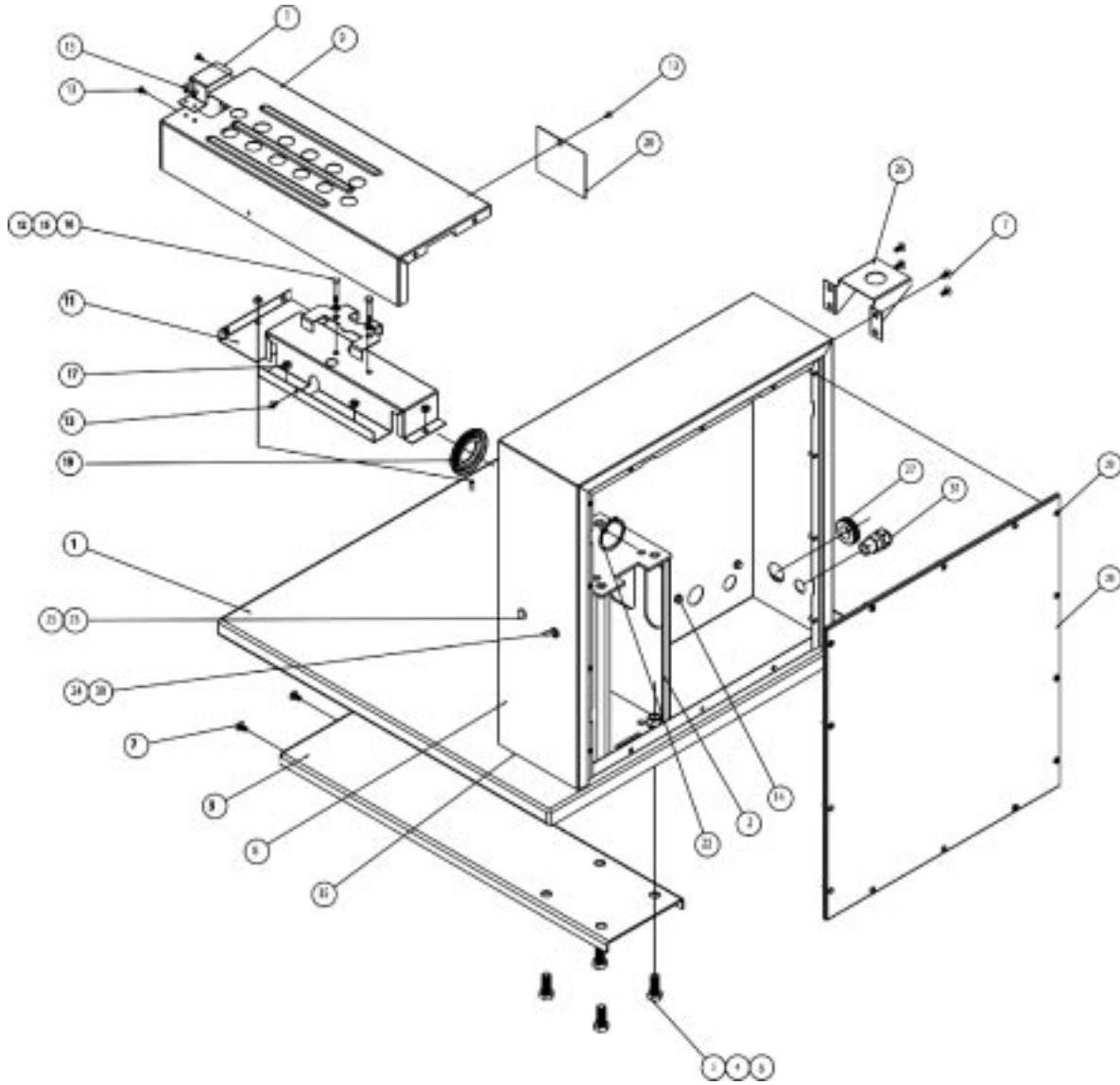

Parts List TDH Units Only

To order parts, contact your Groen Authorized Service Agency. Supply the model designation, part description, part number, quantity, and, where applicable, voltage.

Key	Description	Part No.	Key	Description	Part No.
1	Weldment, Base TDHC-40	137060	19	Seal Trunion	137005
2	Weldment, Pedestal TDHC-40	124735	20	Plate, Shroud Weld ASM (TDH-20)	137700
3	Weldment, Base Support TDHC-40	124729	20	Plate, Shroud Weld ASM (TDH-40)	137380
4	Washer Lock 1/2" S.S.	005657	21	Gasket, 3/8" Thk x 1/2" Wide, 6" Center Cut 1/4" Hole (Not Shown)	137588
5	Screw, Hex HD 1/2-13 x 1 1/4"	005623	22	E-Ring, 1.875" Dia.	138357
6	Nut Hexagon 1/2"-13	005603	23	Light Indicator Red 24VAC	116383
7	Screw Truss HD 1/4-20 x 1/2 S.S.	012700	24	Gasket Switch TDHC-40	137435
8	Asm, Cabinet Weld	137725	25	Gasket Lamp TDHC-40	137434
9	Shroud Burner Weld Asm, TDHC-40	135526	26	Faucet Bracket	137738
10	Shield, Pilot, TDHC-40	135524	27	Grommet 7/8" ID x 1-5/8" OD	007400
11	Burner Bracket Weld Asm.	135527	28	Cover, Cabinet TDHC-40	137004
12	Bracket, Burner Support	137353	29	Screw, 10-32 x 1/2" Combi Head	137766
13	Screw, Truss HD #8-32 x 3/8"	005764	30	Switch SPST ON/OFF	006904
14	Screw, Hex HD 1/4"-20 x 1/2"	005608	31	Connector Straight 3/8" Sealtite	001669
15	Washer Lock 1/4"	005655	32	Harness Asm TDHC-40	137006
16	Screw Hex HD Cap 1/4"-20 x 1-1/2"	005649	33	Harness Asm High Voltage TDCH-40	137456
17	Nut Hexagon Keps 1/4"-20	012940	34	Strap Cable TY-RAP	011093
18	Plate Shroud Weld Asm.	137680	35	Sealant RTV #732, Grey	001711

Parts List TDHC Units Only

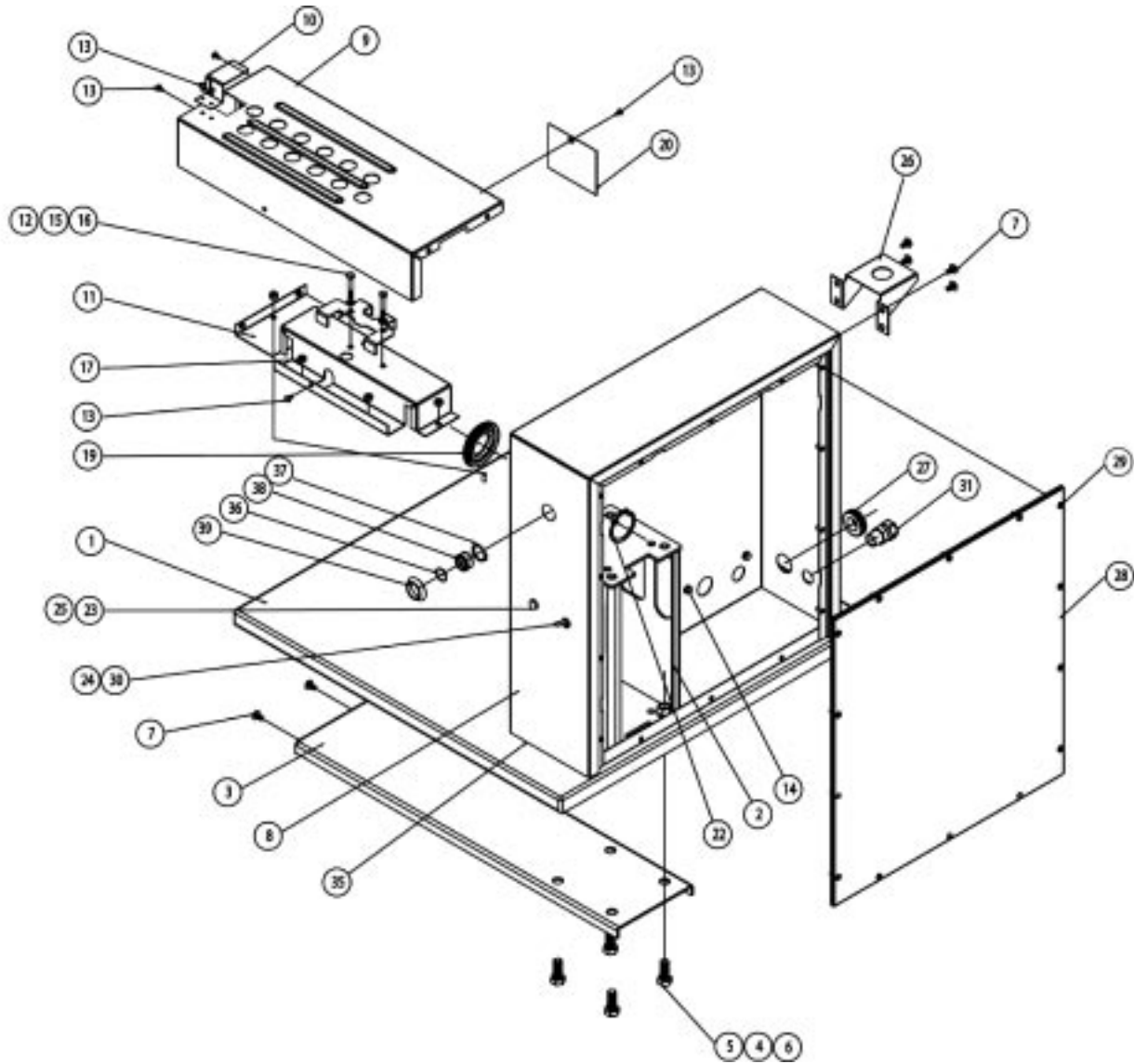

Parts List TDHC Units Only

To order parts, contact your Groen Authorized Service Agency. Supply the model designation, part description, part number, quantity, and, where applicable, voltage.

Key	Description	Part No.	Key	Description	Part No.
1	Weldment, Base TDHC-40	137060	21	Gasket, 3/8" Thk x 1/2" Wide, 6" Center Cut 1/4" Hole (Not Shown)	137588
2	Weldment, Pedestal TDHC-40	124735	22	E-Ring, 1.875" Dia.	138357
3	Weldment, Base Support TDHC-40	124729	23	Light Indicator Red 24VAC	116383
4	Washer Lock 1/2" S.S.	005657	24	Gasket Switch TDHC-40	137435
5	Screw, Hex HD 1/2-13 x 1 1/4"	005623	25	Gasket Lamp TDHC-40	137434
6	Nut Hexagon 1/2"-13	005603	26	Faucet Bracket	137738
7	Screw Truss HD 1/4-20 x 1/2 S.S.	012700	27	Grommet 7/8" ID x 1-5/8" OD	007400
8	Asm, Cabinet Weld	137725	28	Cover, Cabinet TDHC-40	137004
9	Shroud Burner Weld Asm, TDHC-40	135526	29	Screw, 10-32 x 1/2" Combi Head	137766
10	Shield, Pilot, TDHC-40	135524	30	Switch SPST ON/OFF	006904
11	Burner Bracket Weld Asm.	135527	31	Connector Straight 3/8" Sealtite	001669
12	Bracket, Burner Support	137353	32	Harness Asm TDHC-40	137006
13	Screw, Truss HD #8-32 x 3/8"	005764	33	Harness Asm High Voltage TDCH-40	137456
14	Screw, Hex HD 1/4"-20 x 1/2"	005608	34	Strap Cable TY-RAP	011093
15	Washer Lock 1/4"	005655	35	Sealant RTV #732, Grey	001711
16	Screw Hex HD Cap 1/4"-20 x 1-1/2"	005649	36	O-Ring #018	138359
17	Nut Hexagon Keps 1/4"-20	012940	37	E-Ring, 1.00"	138356
18	Plate Shroud Weld Asm.	137680	38	Collar, Shaft Seal, .750"	138354
19	Seal Trunion	137005	39	Seal, Shaft 1.00"	136088
20	Plate, Shroud Weld ASM (TDH-20)	137700			
20	Plate, Shroud Weld ASM (TDH-40)	137380			

Parts List (TDH Units Only)

To order parts, contact your Groen Authorized Service Agency. Supply the model designation, part description, part number, quantity, and, where applicable, voltage.

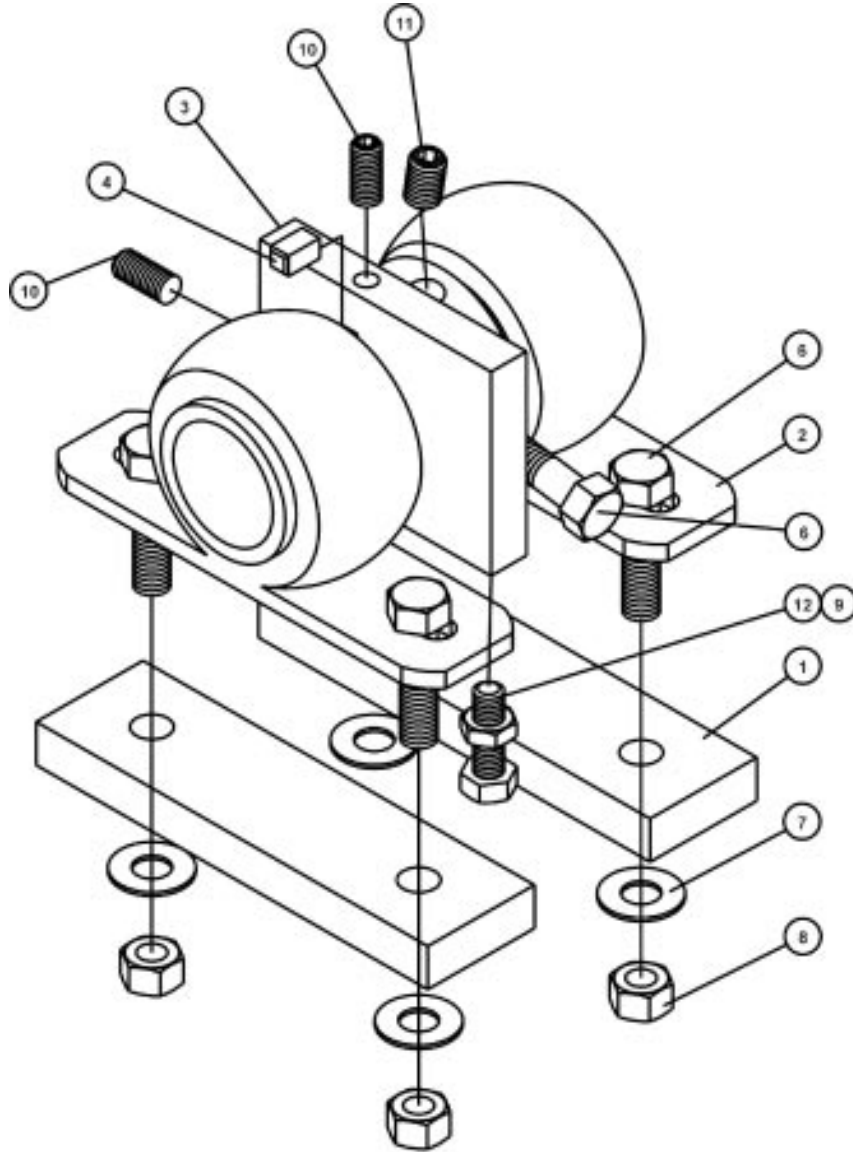

Key	Description	Part No.	Key	Description	Part No.
1	Spacer, Pillow Block	137692	7	Washer Flat 3/8"	005830
2	Pillow Block	002989	8	Nut Hex 3/8"-16	005619
3	Stop, Manual Tilt, TDH-40	137697	9	Nut Hex 5/16"-18	005602
4	Key, 1/4 Sq x .5" Lg, TDH-20	137746	10	Screw Set Socket	086617
5	Collar Set 1-1/2" ID x 2-1/4" OD x 3/4" Thk	003118	11	Screw Set Socket	003400
6	Screw Hex HD Cap 3/8"-16 x 1-1/2"	005615	12	Screw Hex HD Cap 5/16"-18 x 1"	005613

Parts List (TDHC Units Only)

To order parts, contact your Groen Authorized Service Agency. Supply the model designation, part description, part number, quantity, and, where applicable, voltage.

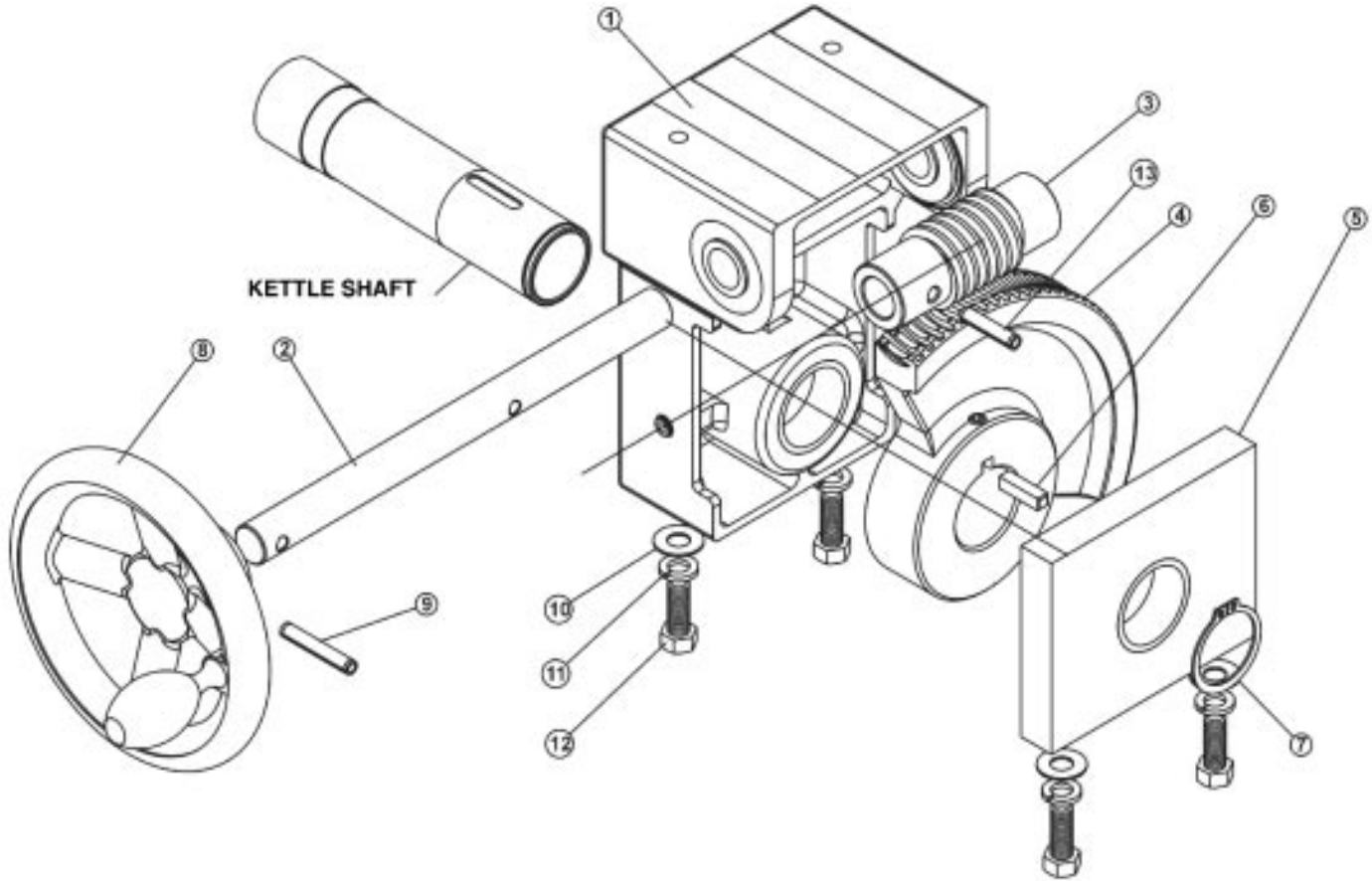

Key	Description	Part No.	Key	Description	Part No.
1	Assembly, Gear Carrier	124741	8	Assembly, Handwheel	124719
2	Shaft, Worm	122374	9	Pin, Roll 1/4" x 1.63 Lg.	128036
3	Gear, Worm	128001	10	Washer, Flat 3/8"	005830
4	Assembly, Gear Sector	128028	11	Washer, Lock 3/8"	005618
5	Assembly, Bearing Block	128021	12	Screw, 3/8-16 x 1" Hex HD	005612
6	Key, 1/4 Sq x 1" Lg.	122371	13	Pin, Roll 1/4" x 1.25" Lg.	012614
7	Retaining Ring 1.500	124764			

Parts List TDH and TDHC

To order parts, contact your Groen Authorized Service Agency.
Supply the model designation, part description, part number, quantity, and, where applicable, voltage and phase.

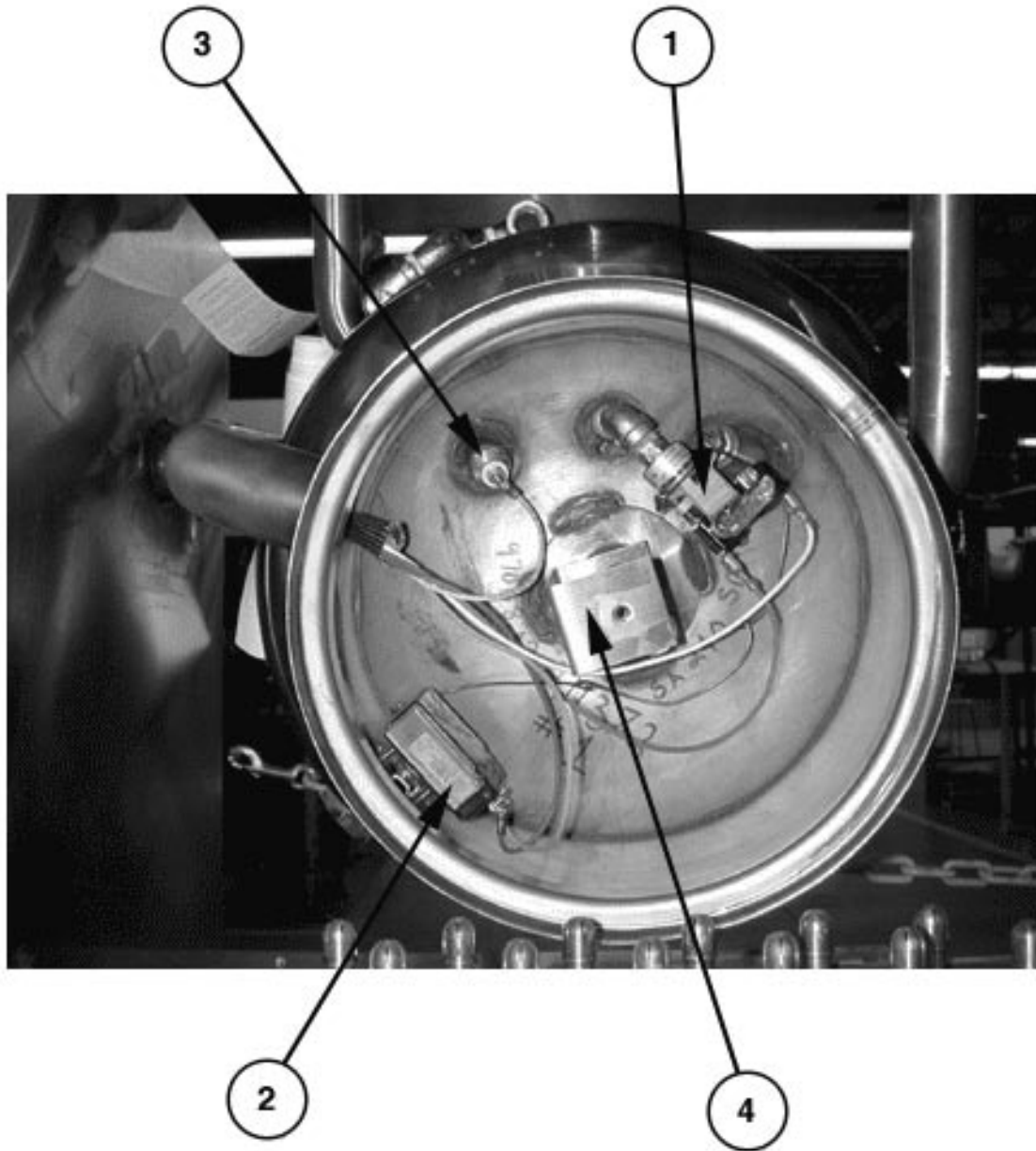

Key	Description	Part No.	Key	Description	Part No.
1	Pressure Switch	096963	5	Cover (NOT SHOWN)	003141
2	Thermostat	012313	6	Gasket, Bottom Cover (NOT SHOWN)	137969
3	Water Level Electrode	015589	7	Screw, ¼-20 x 1 ½ (NOT SHOWN)	012597
4	Bracket	137736	8	Gasket, Bottom Cover Screw (NOT SHOWN)	137968

Parts List

To order parts, contact your Groen Authorized Service Agency. Supply the model designation, part description, part number, quantity, and, where applicable, voltage and phase.

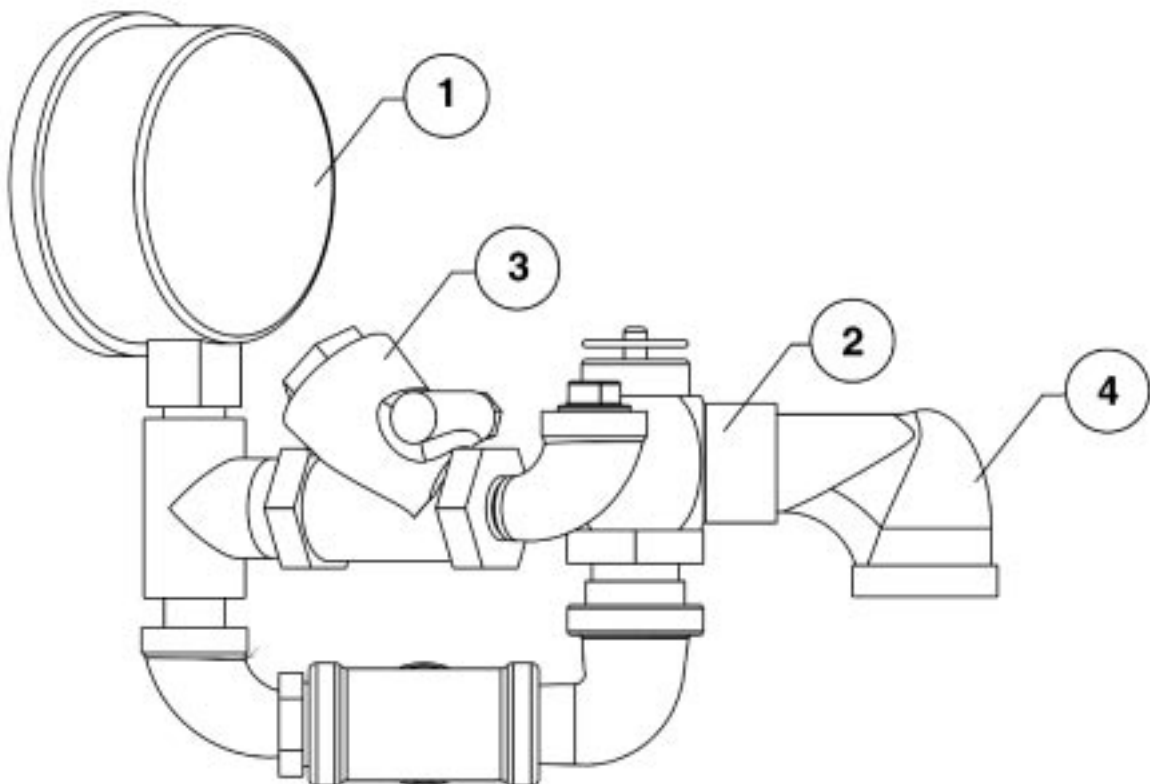
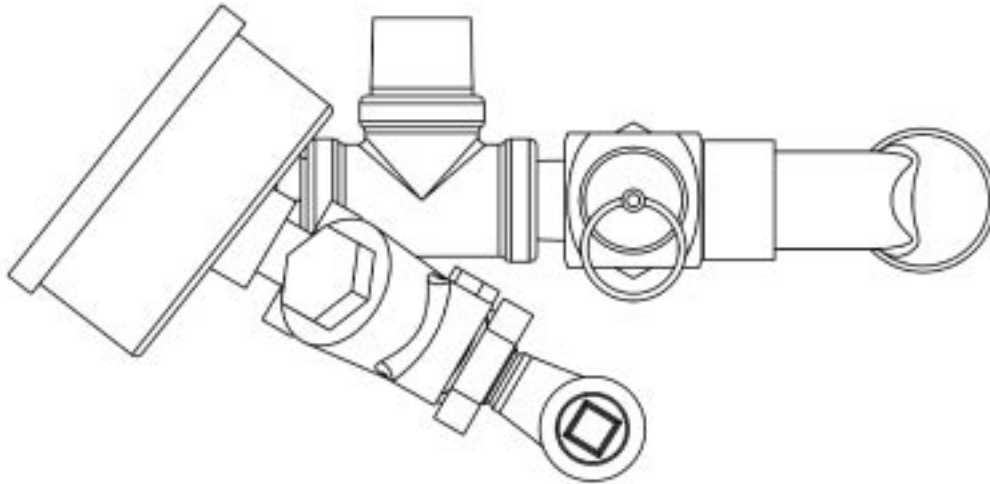

Key	Description	Part No.	Key	Description	Part No.
1	Gauge, Compound Pressure w/Dual	084208	3	Assy, Water Fill Sub	137438
2	Valve, Pressure Relief 50 PSI	097005	4	Elbow, 1/2" NPT 90 Deg Street Blk	096905

Parts List

To order parts, contact your Groen Authorized Service Agency. Supply the model designation, part description, part number, quantity, and, where applicable, voltage.

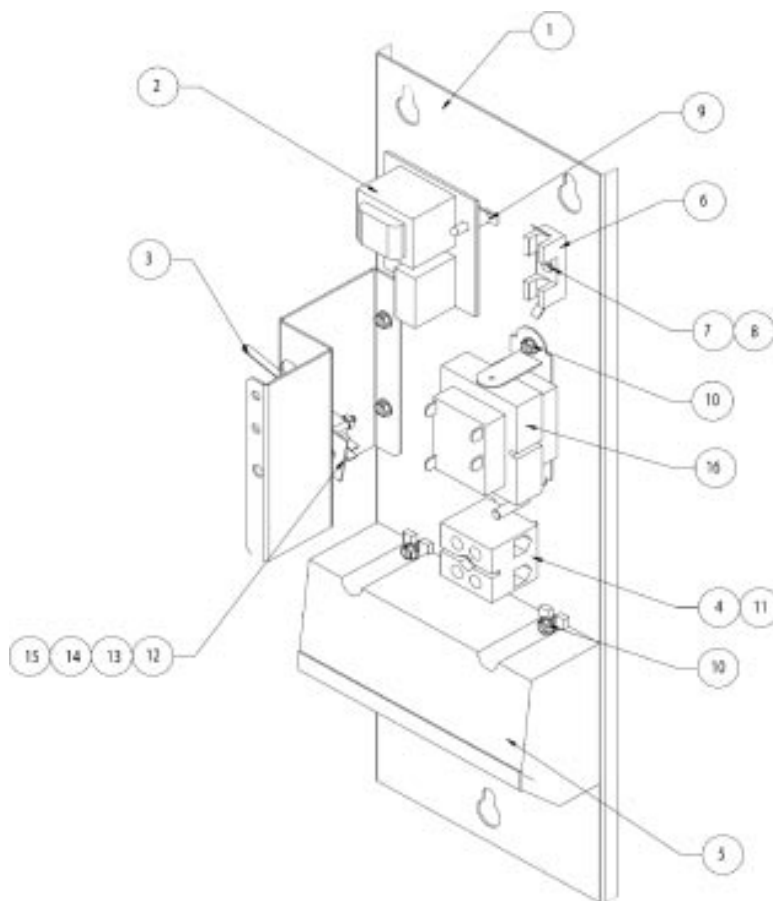

Key	Description	Part No.	Key	Description	Part No.
1	Elec. Mounting Bracket	137489	9	P. C. Board Mounting Post	099901
2	Control, Water Level, 24 V	122192	10	Screw, 8 x 3/8 lg. hex slot (for #5 and #17)	069789
3	Micro Switch	002982	11	Screw #8-32 x 1-1/4 Rnd Head (for #4)	005056
4	Terminal Block, two pole	003887	12	Screw, Round Head 4-40 x 3/4 lg. (for #3)	003122
5	Ignition Module	085153	13	Barrier Insulation (for #3)	003490
6	Fuse, Holder, Type 3 AG	077854	14	Washer shakeproof Lock, #6 (for #3)	005715
7	Fuse, three Amp Type 3 AG	077853	15	Nut, Hex 4-40 (for #3)	003121
8	Screw, 6-32 x 3/8 lg (for #6)	009697	16	Transformer, 20 VA 120 V	137487

Schematic

TDH & TDHC

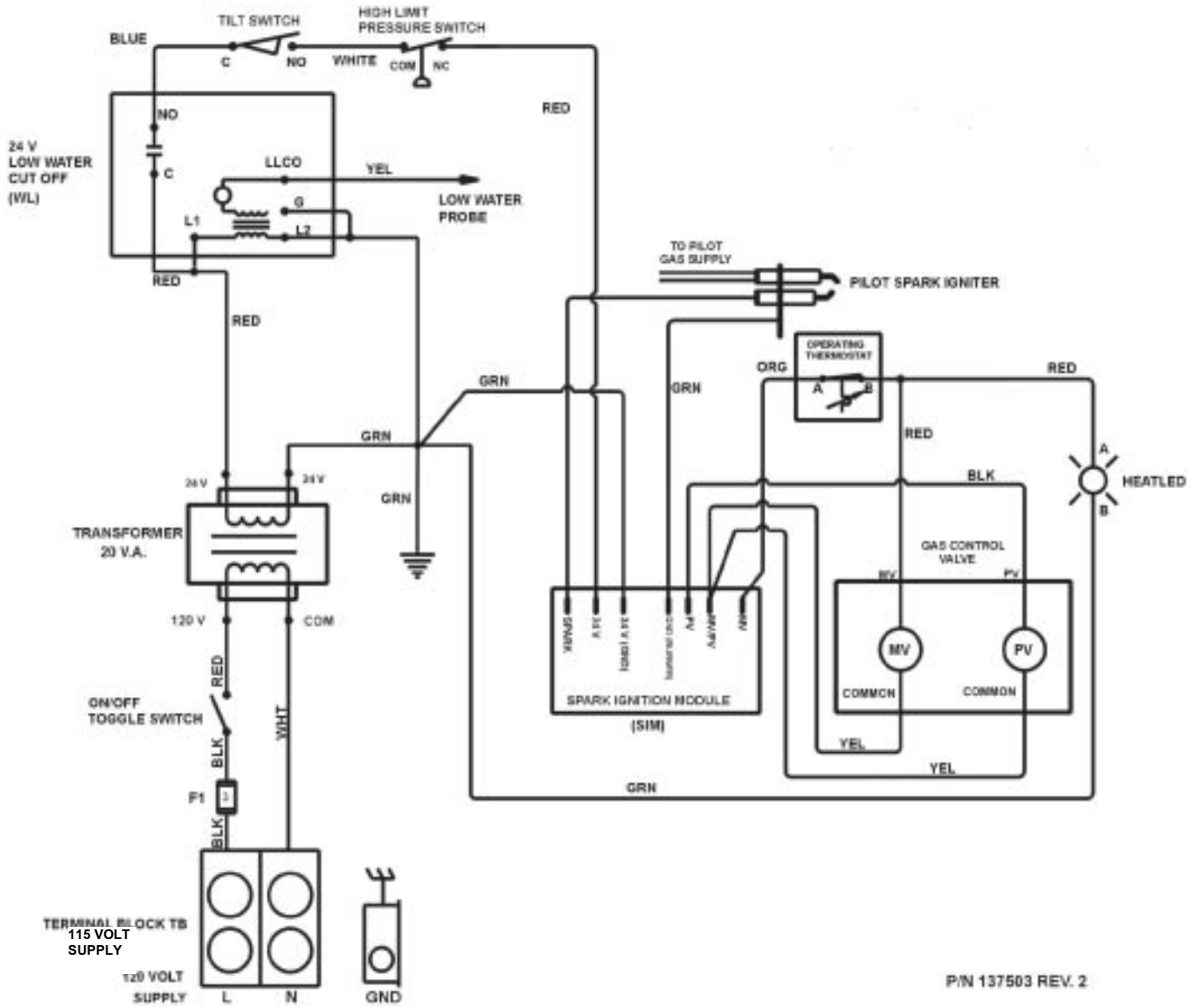

P/N 137503 REV. 2