

☆ **IMPORTANT INFORMATION** ☆ **KEEP FOR OPERATOR** ☆ **IMPORTANT INFORMATION** ☆

## OPERATOR MANUAL

Part Number 121066 Rev. C

## OM-TD/FPC

DOMESTIC

**MODEL: TD/FPC**  
**Braising Pan**

*Stainless Steel*  
*Table Top Mounted*  
*Manual Tilting*  
*Electrically Heated*  
*40 Quart Capacity*



**THIS MANUAL MUST BE RETAINED FOR FUTURE REFERENCE. READ, UNDERSTAND AND FOLLOW THE INSTRUCTIONS AND WARNINGS CONTAINED IN THIS MANUAL.**

**WARNING**  
**DO NOT STORE OR USE GASOLINE OR OTHER FLAMMABLE VAPORS AND LIQUIDS IN THE VICINITY OF THIS OR ANY OTHER APPLIANCE.**



Packaging - Processing  
**Bid on Equipment**  
1-847-683-7720  
[www.bid-on-equipment.com](http://www.bid-on-equipment.com)

**IMPORTANT — READ FIRST — IMPORTANT**

- CAUTION:** BE SURE OPERATORS READ, UNDERSTAND AND FOLLOW THE OPERATING INSTRUCTIONS, CAUTIONS, AND SAFETY INSTRUCTIONS IN THIS MANUAL.
- WARNING:** THIS UNIT IS INTENDED FOR USE IN THE COMMERCIAL HEATING, COOKING AND HOLDING OF WATER AND FOOD PRODUCTS, PER THE INSTRUCTIONS CONTAINED IN THIS MANUAL. ANY OTHER USE COULD RESULT IN SERIOUS PERSONAL INJURY OR DAMAGE TO EQUIPMENT AND WILL VOID WARRANTY.
- WARNING:** ELECTRICALLY GROUND THE PAN AT THE TERMINAL PROVIDED.
- WARNING:** THE BRAISING PAN MUST BE INSTALLED BY PERSONNEL WHO ARE QUALIFIED TO WORK WITH ELECTRICITY. IMPROPER INSTALLATION COULD RESULT IN PERSONAL INJURY OR EQUIPMENT DAMAGE.
- CAUTION:** STAND AWAY FROM HOT WATER OR FOOD PRODUCTS WHILE TILTING THE PAN
- WARNING:** WHEN TILTING BRAISING PAN FOR PRODUCT TRANSFER:
- 1) USE CONTAINER DEEP ENOUGH TO CONTAIN AND MINIMIZE SPLASHING.
  - 2) PLACE CONTAINER ON STABLE, FLAT SURFACE, AS CLOSE TO PAN AS POSSIBLE.
  - 3) STAND TO SIDE OF PAN WHILE POURING — NOT DIRECTLY IN POUR PATH OF HOT CONTENTS.
  - 4) RETURN PAN BODY TO LEVEL POSITION AFTER CONTAINER IS FILLED OR TRANSFER IS COMPLETE.
  - 5) DO NOT OVER FILL CONTAINER. AVOID DIRECT SKIN CONTACT WITH HOT CONTAINER AND ITS CONTENTS.
- WARNING:** DO NOT HEAT AN EMPTY PAN FOR MORE THAN FIVE MINUTES AT A SETTING HIGHER THAN 300° F.
- WARNING:** AVOID ANY EXPOSURE TO THE STEAM ESCAPING FROM THE COVER VENT. DIRECT CONTACT COULD RESULT IN SEVERE BURNS
- WARNING:** AVOID ALL DIRECT CONTACT WITH HOT EQUIPMENT SURFACES. DIRECT SKIN CONTACT COULD RESULT IN SEVERE BURNS.
- WARNING:** AVOID ALL DIRECT CONTACT WITH HOT FOOD OR WATER IN THE BRAISING PAN. DIRECT CONTACT COULD RESULT IN SEVERE BURNS.
- WARNING:** IF THE PAN CONTAINS ITEMS IN SAUCE OR MELTED FAT, THEY COULD SLIDE FORWARD SUDDENLY DURING TILTING AND CAUSE HOT LIQUID TO SPLASH OUT.
- WARNING:** USE OF ANY REPLACEMENT PARTS OTHER THAN THOSE SUPPLIED BY GROEN OR ITS AUTHORIZED DISTRIBUTORS VOIDS ALL WARRANTIES AND MAY CAUSE BODILY INJURY OR EQUIPMENT DAMAGE. SERVICE PERFORMED BY OTHER THAN FACTORY AUTHORIZED PERSONNEL WILL VOID ALL WARRANTIES.
- WARNING:** TURN OFF ELECTRIC POWER BEFORE WORKING ON INTERNAL COMPONENTS.
- WARNING:** BEFORE ANY CLEANING OPERATION, TURN THE THERMOSTAT TO “OFF” TO CUT OFF POWER TO THE HEATING ELEMENTS. BEFORE CLEANING ANY PART OTHER THAN THE INSIDE OF THE PAN, DISCONNECT THE ELECTRICAL SUPPLY AT THE CIRCUIT BREAKER OR FUSE BOX.
- WARNING:** BE CAREFUL TO AVOID CONTACT WITH CLEANING PRODUCTS IN ACCORDANCE WITH SUPPLIER AND MANUFACTURER RECOMMENDATIONS. MANY CLEANERS ARE HARMFUL TO THE SKIN, EYES, MUCOUS MEMBRANES AND CLOTHING. READ THE WARNINGS AND FOLLOW DIRECTIONS ON THE CLEANER LABEL.
- CAUTION:** NEVER LEAVE A CHLORINE SANITIZER IN CONTACT WITH STAINLESS STEEL FOR LONGER THAN 30 MINUTES. LONGER CONTACT CAN CAUSE CORROSION.
- WARNING:** DO NOT USE ANY FUSE WITH A HIGHER AMP RATING THAN THE RATING SPECIFIED FOR THAT CIRCUIT.

Table of Contents

IMPORTANT OPERATOR WARNINGS 2
REFERENCES 3
EQUIPMENT DESCRIPTION 4
INSTALLATION 4
INITIAL START-UP 5
OPERATION 5
SEQUENCE OF OPERATION 6
CLEANING 7
MAINTENANCE 8
TROUBLESHOOTING 9
PARTS LISTS 10
ELECTRICAL PARTS CHART 11
ELECTRICAL SCHEMATICS 12
SERVICE LOG 14
WARRANTY 15

References

UNDERWRITERS LABORATORIES, INC. 333 Pfingsten Road Northbrook, Illinois 60062
NATIONAL FIRE PROTECTION ASSOCIATION 60 Battery March Park Quincy, Massachusetts 02269
NSF INTERNATIONAL 789 N. Dixboro Rd. P.O. Box 130140 Ann Arbor, Michigan 48113-0140
NFPA/70 The National Electrical Code
KLENZADE SALES CENTER ECOLAB, INC. 370 Wabasha St. Paul, Minnesota 55102 800/328-3663 or 612/293-2233
ZEP MANUFACTURING 1310-T Seaboard Industrial Blvd. Atlanta, Georgia 30318



## Equipment Description

The Groen TD/FPC electrically heated braising pan provides a 40 quart, stainless steel pan body mounted for tilting and equipped with electric heating elements and a thermostatic control. The braising pan serves as a braising unit, griddle, fry pan, kettle, or bain-marie, and with optional equipment may be used also as an oven or food warmer/server.

The pan body is made of heavy-duty stainless steel welded into one piece with a polished interior and semi-deluxe finish on the exterior. A pouring lip is molded into the front wall. The cooking surface is stainless steel clad plate fitted with clamped-on electric heating elements to provide efficient heat transfer over the entire surface.

The heating elements and all other electrical components of the unit are enclosed for safety. The thermostat and indicator light are contained in a compact control console mounted to the right of the pan body. Installation requires only one electrical connection.

The pan body and control console are mounted on a base plate. A convenient handle on the right side of the pan body facilitates tilting.

Optional equipment includes:

1. Fill faucet with swing spout
2. One piece, lift-off cover
3. TS/8 support stand

BRAISING PAN CHARACTERISTICS		
Capacity	40 Quarts	37.85 liters
Pan Width	18 inches (inside)	457 mm (inside)
Pan Length (front to back)	27 inches (inside)	686 mm (inside)
Pan Depth	7 inches	178 mm
Base Width	28.5 inches	724 mm
Base (front to back)	18 inches	457 mm
Power at 208 Volts	5.7 KW	
Power at 240 Volts	6.0 KW	
Power at 380 Volts	6.0 KW	
Power at 480 Volts	6.0 KW	

## Installation

**WARNING**  
**THE BRAISING PAN MUST BE INSTALLED BY PERSONNEL WHO ARE QUALIFIED TO WORK WITH ELECTRICITY. IMPROPER INSTALLATION COULD RESULT IN PERSONAL INJURY OR EQUIPMENT DAMAGE.**

Internal wiring for the Braising Pan is supplied complete. When you receive the unit, it is ready for connection. A wiring diagram is located inside the console on the side of the pan, as well as in this manual (pp. 14-21).

Your pan was performance-tested at the factory to confirm that its controls and heating elements were functioning correctly.

### Installation is as follows:

1. Set the unit in place on a level surface. The unit must be level to avoid uneven cooking across the pan.
2. Provide the proper electric power supply as specified on the electrical information plate. Observe local codes and/or The National Electrical Code in accordance with ANSI/NFPA 70 - latest edition.
3. Bringing the electrical service through the entrance in the control box, make a waterproof connection with the incoming lines. A BX connection is not recommended. **GROUND THE UNIT ELECTRICALLY AT THE TERMINAL PROVIDED.**

## Initial Start-Up

Now that the Braising Pan has been installed, you should test it to ensure that it is operating correctly.

1. Remove all literature and packing materials from the interior and exterior of the unit.
2. Turn on the electrical power to the unit.
3. Put enough water into the pan to cover its bottom to a depth of  $\frac{1}{4}$ " to  $\frac{1}{2}$ " (6 to 13 mm). With the pan body in the horizontal position, note how the water covers the pan bottom. This is a good method to use for confirming that the unit is properly leveled.

4. Set the thermostat to 235° F. The heating indicator light should come on to show that the pan is heating. Heating should continue until the water boils.
5. To shut the unit down, turn the thermostat dial to "OFF."

**CAUTION**  
**STAND AWAY FROM THE HOT WATER**  
**WHILE TILTING THE PAN TO EMPTY IT.**

6. Position a container for the pour-off. Turn the handwheel clockwise to pour the water out. This will confirm that the pan body tilts from horizontal to vertical.

## Operation

The operator controls braising pan operation with the thermostat dial, which is located on the right front of the unit. Setting the dial sends electric power to turn the heaters on or off and sets the operating temperature of the pan.

### A. To Start Pan

1. Turn on the electric power supply to the unit.
2. Turn the thermostat dial to a desired setting between 100 and 400°F (38 and 204°C). The red indicator light will glow, showing that the pan is heating. The light will cycle on and off, which indicates that the pan is being held at the set temperature. Once in each cycle the contactors in the control box will make a clicking sound. This is normal.
3. For best braising or frying results, preheat the pan before you put in any food. To get an even temperature across the pan, preheat at a setting of 300° F (149° C) or less for 15 minutes (several thermostat on/off cycles).

**WARNING**  
**DO NOT HEAT AN EMPTY PAN FOR MORE THAN FIVE MINUTES AT SETTINGS ABOVE 300°F. DAMAGE TO THE PAN COULD RESULT.**

### B. Cooking

1. To simmer or slowly heat an item, set the dial at about 210° F (99° C) or lower. Put the optional cover on the pan to keep moisture loss at a minimum, or leave it off to help dry or reduce the product. Set the thermostat higher to cook or drive moisture off faster. The thermostat may be adjusted to any setting in its range to cook exactly as you wish.
2. When using the optional cover, leave the cover vent open to allow excess steam to escape. For longer simmering, you may wish to close the vent to retain moisture.
3. Be careful when lifting the optional cover. Lift its rear edge a few inches to allow any steam or and hot vapor to escape the pan. Then tilt it further to allow any hot condensate to roll off the cover and back into the pan.



**WARNING**  
**AVOID ANY EXPOSURE TO THE STEAM ESCAPING FROM THE COVER VENT. DIRECT CONTACT COULD RESULT IN SEVERE BURNS**

## OM/SM-TD/FPC

4. To pour or dump product, remove grease, or assist cleaning, first remove the cover, then tilt the pan. Be careful!



**WARNING**  
**AVOID ALL DIRECT CONTACT WITH HOT EQUIPMENT SURFACES. DIRECT SKIN CONTACT COULD RESULT IN SEVERE BURNS.**  
**AVOID ALL DIRECT CONTACT WITH HOT FOOD OR WATER IN THE BRAISING PAN. DIRECT CONTACT COULD RESULT IN SEVERE BURNS.**

**WARNING**  
**IF THE PAN CONTAINS ITEMS IN SAUCE OR MELTED FAT, THEY COULD SLIDE FORWARD SUDDENLY DURING TILTING AND CAUSE THE HOT LIQUID TO SPLASH OUT.**

### C. To Shut Down the Pan

1. Turn the thermostat dial to "OFF".
2. For prolonged shut-down, or before cleaning the outside of the unit, completely shut off the power supply to the unit.

### D. Routine Cleaning

After each use, turn the thermostat to "OFF" and clean all food-contact surfaces. At the end of each day, or at least once every 12 hours, turn off electric power to the unit, and clean both the interior and the exterior. See detailed cleaning instructions in the Maintenance section of this manual.

## Sequence of Operation

The following "action-reaction" outline is provided to help you understand how the braising pan actually functions.

When you start the pan by turning the thermostat dial from "OFF" to a desired temperature, the thermostat switch closes. This action causes the contactors to close, allowing power to flow to the heating elements and the indicator light. When the temperature of the pan rises to the value set on the thermostat dial, the thermostat switch opens and causes the contactors to open. This stops the flow of power to the heaters and indicator light.

As soon as the thermostat senses that the pan has cooled below the set temperature, the thermostat switch closes, the contactors close, and the heaters and indicator light come on again.

This on-off cycling continues, holding the pan at the set temperature. These cycles cause the indicator light to go on and off during normal operation.

If the pan temperature rises above 425°F (218°C) for any reason, a high-limit thermostat shuts off power until the pan cools. At that point the thermostat automatically resets and allows normal operation to begin again.

Setting the thermostat dial to "OFF" shuts down all control and heating circuits.

The thermostat controls heating by alternately feeding full power and completely cutting off power. The pan will heat as fast as it can until it reaches the set temperature, no matter what that temperature is. Turning the thermostat dial to a higher setting will only cause heating to continue longer, until the pan reaches the higher temperature. It will not make the pan heat any faster.

# Cleaning

## A. Suggested Tools

- 1. Cleaner, such as Klenzade
- 2. Brushes in good condition
- 3. Cloth for cleaning controls
- 4. Chlorine sanitizer such as Klenzade
- 5. Heavy Duty Cleaner, such as Klenzade LC-30

## B. Procedure



**WARNING**  
**BEFORE ANY CLEANING OPERATION, TURN THERMOSTAT DIAL TO "OFF" TO CUT ANY POWER TO THE HEATING ELEMENTS. BEFORE CLEANING ANY PART OTHER THAN THE INSIDE OF THE PAN, DISCONNECT ELECTRICAL SUPPLY AT CIRCUIT BREAKER OR FUSE BOX.**

- 1. Clean all food-contact surfaces soon after use. It is best to clean the pan before it has completely cooled. If the unit is in continuous use, completely clean and sanitize both the inside and outside at least once every 12 hours.

**CAUTION**  
**KEEP WATER AND CLEANING SOLUTIONS OUT OF CONTROLS AND ELECTRICAL EQUIPMENT. DO NOT SPRAY OR HOSE THE CONTROL BOX OR OTHER ELECTRICAL CONNECTIONS. THEY ARE NOT WATER-PROOF.**

- 2. To remove any large amount of food left in the pan, tilt the pan all the way up and flush it with lukewarm water. Do not damage the surface of the pan by scraping it with a metal tool. Scratches make the surface more difficult to clean, and provide ideal breeding places for bacteria.



**CAUTION**  
**MOST CLEANERS ARE HARMFUL TO THE SKIN, EYES, MUCOUS MEMBRANES, AND CLOTHING. PRECAUTIONS SHOULD BE TAKEN. WEAR RUBBER GLOVES, GOGGLES OR FACE SHIELD AND PROTECTIVE CLOTHING. READ THE WARNINGS AND CAREFULLY FOLLOW THE DIRECTIONS ON THE CLEANER LABEL.**

- 3. Following the supplier's directions, make up a warm solution of the cleaner. Carefully wash the inside and outside of the pan body with the cleaning solution.
- 4. Use a cloth moistened with cleaning solution to clean controls, the control console, and electric conduit.



Don't use metal implements or steel wool when cleaning.



Use a brush, sponge, cloth, plastic or rubber scraper, or plastic wool to clean.

## OM/SM-TD/FPC

5. Rinse the pan very well with lukewarm water, and drain it completely.
6. As part of the daily cleaning program, clean all inside and outside surfaces that may have been soiled. Remember to check such parts as the electrical console and other remote spots. Clean between the pan body and the console using the brush provided (P/N 058705).
7. To remove materials stuck to the equipment, use a brush, sponge, cloth, plastic or rubber scraper, or plastic wool with the cleaning solution. To make washing easier, let the cleaning solution sit in the unit and soak into the residue, or briefly heat the solution. Do **not** use any gritty cleaner or metal tool that might scratch the surface. Scratches make the surface harder to clean and provide places for bacteria to grow. **Do not use steel wool.** Small bits of steel wool left in the surface of the unit can cause rusting and pitting.
8. The outside of the unit may be polished with a recognized stainless steel cleaner such as Zepper from the Zep Manufacturing Company.
9. When the equipment needs to be sanitized, use a sanitizing solution equivalent to one that supplies 100 parts per million available chlorine. Get advice about the best sanitizing agent from your supplier of sanitizing products.
10. Following supplier instructions, apply the sanitizing agent after the unit has been cleaned and drained. Thoroughly drain off the sanitizer.
11. After the unit has been cleaned, sanitized and drained, let all surfaces air dry unless the unit must be used again right away.
12. It is recommended that the unit be sanitized just before use. Follow the directions of the sanitizer supplier.
13. About once a week (more often if the water is very hard), use a heavy duty cleaner to remove mineral deposits or film left by hard water or foods. Follow the supplier's directions very carefully, and thoroughly rinse the unit off as soon as cleaning is finished.
14. If especially difficult cleaning problems persist, contact your cleaning product supplier for help. The supplier has a trained technical staff with laboratory facilities to serve you.

**CAUTION**  
**NEVER LEAVE A CHLORINE SANITIZER IN CONTACT WITH STAINLESS STEEL SURFACES FOR LONGER THAN 30 MINUTES. LONGER CONTACT CAN CAUSE CORROSION.**

## Maintenance

**WARNING**  
**USE OF REPLACEMENT PARTS OTHER THAN THOSE SUPPLIED BY GROEN OR THEIR AUTHORIZED DISTRIBUTORS CAN CAUSE INJURY TO THE OPERATOR AND DAMAGE TO THE EQUIPMENT AND WILL VOID ALL WARRANTIES. SERVICE PERFORMED BY OTHER THAN FACTORY-AUTHORIZED PERSONNEL WILL VOID ALL WARRANTIES.**

Your Braising Pan is designed to require minimum maintenance, but some parts may require replacement after prolonged use. After installation, no user adjustment should be necessary. If a service need arises, only authorized personnel should perform the work.

Service personnel should check the unit at least once a year. This should include inspecting wires and connections and cleaning inside the control console. A Maintenance and Service Log is provided at the rear of this manual. Each time work is performed, enter the date on which it was done, what was done, and who did it.

**WARNING**  
**ELECTRICAL POWER MUST BE SHUT OFF BEFORE WORK IS DONE ON INTERNAL COMPONENTS.**

## Troubleshooting

Your Groen Braising Pan will operate smoothly and efficiently if properly maintained. However, the following is a list of checks to make in the event of a problem. If the actions suggested do not solve the problem, call your authorized Groen Service Representative. For the phone number of the nearest agency, call your area Groen representative or the Groen Parts and Service Department. If an item on the list is followed by X, the work should only be performed by a qualified service representative.

<b>WARNING</b>		
<b>USE OF ANY REPLACEMENT PARTS OTHER THAN THOSE SUPPLIED BY GROEN OR THEIR AUTHORIZED DISTRIBUTORS CAN CAUSE INJURY TO THE OPERATOR AND DAMAGE TO THE EQUIPMENT AND WILL VOID ALL WARRANTIES.</b>		
<b>SERVICE PERFORMED BY OTHER THAN FACTORY-AUTHORIZED PERSONNEL WILL VOID ALL WARRANTIES.</b>		
<b>SYMPTOM</b>	<b>WHO</b>	<b>WHAT TO CHECK</b>
		X indicates items which must be performed by an authorized technician.
Pan will not heat, but indicator light comes on.	Auth Service Rep Only	a. Heating elements for short circuit. X
Pan will not heat, and indicator light will not light	User	a. That power supply is on. b. Fuse(s).
	Auth Service Rep Only	c. For loose or broken wires. X d. Thermostat functioning, by listening for a click when the switch opens or closes. X e. Contactor functioning. X
Pan continues to heat after it reaches desired temperature	User	a. Thermostat dial setting. Turn down if too high.
	Auth Service Rep Only	b. Thermostat functioning. X c. Thermostat calibration. X d. Contactor, to determine if it is de-energized. X
Pan does not reach desired temperature.	User	a. Thermostat dial setting. Turn up if too low.
	Auth Service Rep Only	b. Heating elements for ground short or open (burned out) element. X c. Thermostat functioning, by listening for a click when the switch opens or closes. X d. Thermostat calibration. X e. Contactor functioning. X
Rapid clicking noise (chattering)	User	a. For low voltage.
	Auth Service Rep Only	b. Contactor for dirt or corrosion on the contacts. X
Uneven cooking due to "hot spots."	User	a. That the pan body is level
Uneven cooking due to "cold spots."	Auth Service Rep Only	a. For open (burned out) heating element. X b. That elements are fastened tightly to pan body. X c. That the pan body is level. X

### Parts List

To order parts, contact your authorized Groen Service Agency. Supply the model designation (TD/FPC), part description, part number and quantity required. Where applicable, provide the voltage and phase as well.

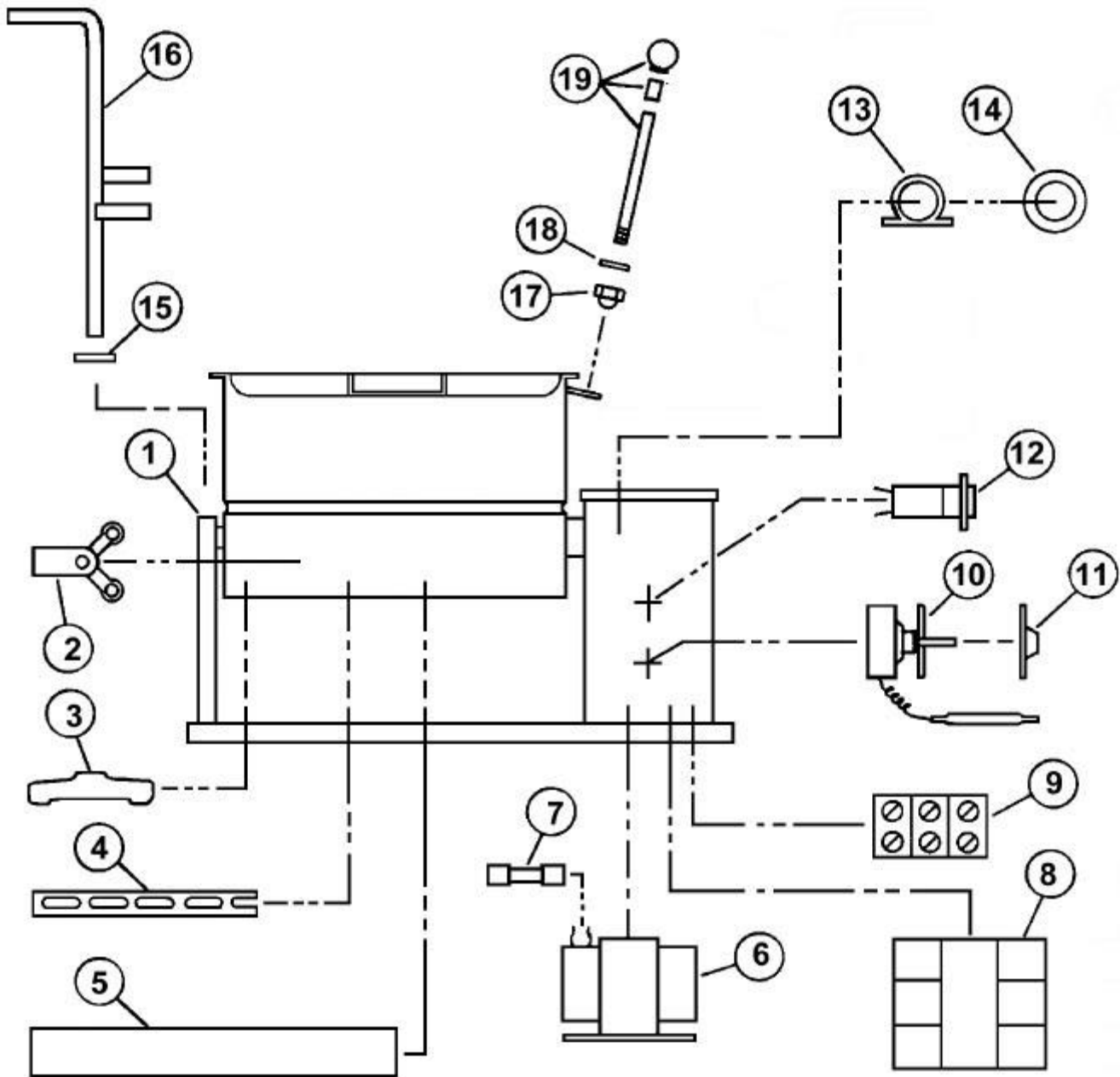

**Parts List**

Key	Description	Part No.	Key	Description	Part No.
1	Outboard Support Assembly	003696	9	Block, Terminal	003119
2	Thermostat, High Limit	012840	10	Thermostat, Control	012838
3	Clamp, Strip Heater	012844	11	Knob, Thermostat	003908
4	Bar, Bus, 36"	012845	12	Light, Indicator, 208 & 240 Volt	016028
5	Heater, Strip 208 Volt, 950 Watts	012842		Light, Indicator, 480 Volt	002986
	Heater, Strip 240 Volt, 1000 Watts	012843	13	Block, Pillow, 1-1/2" ID	002989
	Heater, Strip 480 Volt, 1000 Watts	012908	14	Collar, Set 1-1/2" ID	003118
6	Transformer, 380 Volt	001860	15	Washer, Plain. 1/2"	002213
	Transformer, 480 Volt	012827	16	Tilt Detent Assembly	002970
7	Fuse, 1 AMP, 480 Volt	004324	17	Nut, Cap, 3/8-24	003188
8	Contactor, 208 & 240 Volt, 1 Phase	009178	18	Washer, Lock, 3/8	005618
	Contactor, 208 & 240 Volt, 3 Phase	009210	19	Handle	012694
	Contactor, 480 Volt, 3 Phase	009574			

**Electrical Parts**

Model	Contactor		Heater		Indicator Light	Transformer
	Qty.	Part No.	Qty.	Part No.		
208 V/1 Ph	1	9178	6	12842	16028	None
208 V/3 Ph	1	9210	6	12842	16028	None
240 V/1 Ph	1	9178	6	12843	16028	None
240 V/3 Ph	1	9210	6	12843	16028	None
380 V/3 Ph	1	9574	6	12843	2986	1860
480 V/3 Ph	1	9574	6	12908	2986	12827

### Electrical Schematics

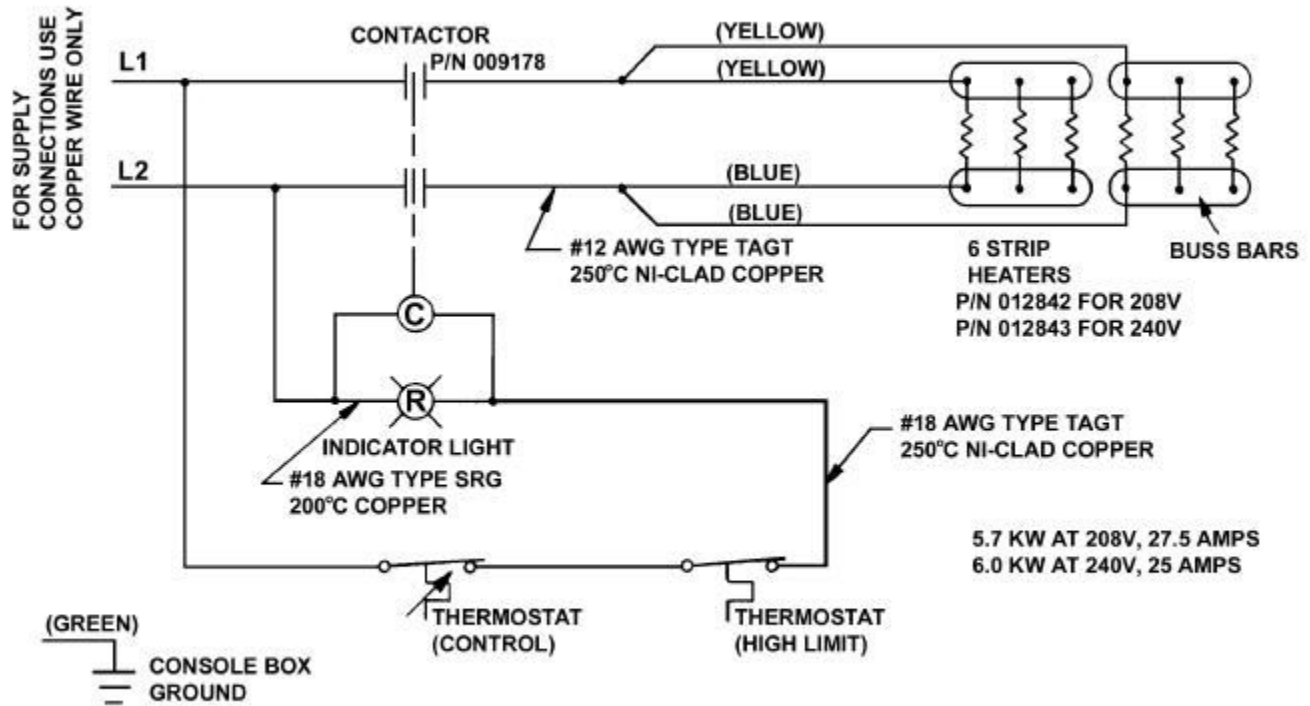

**208/240 V, 1 PH**

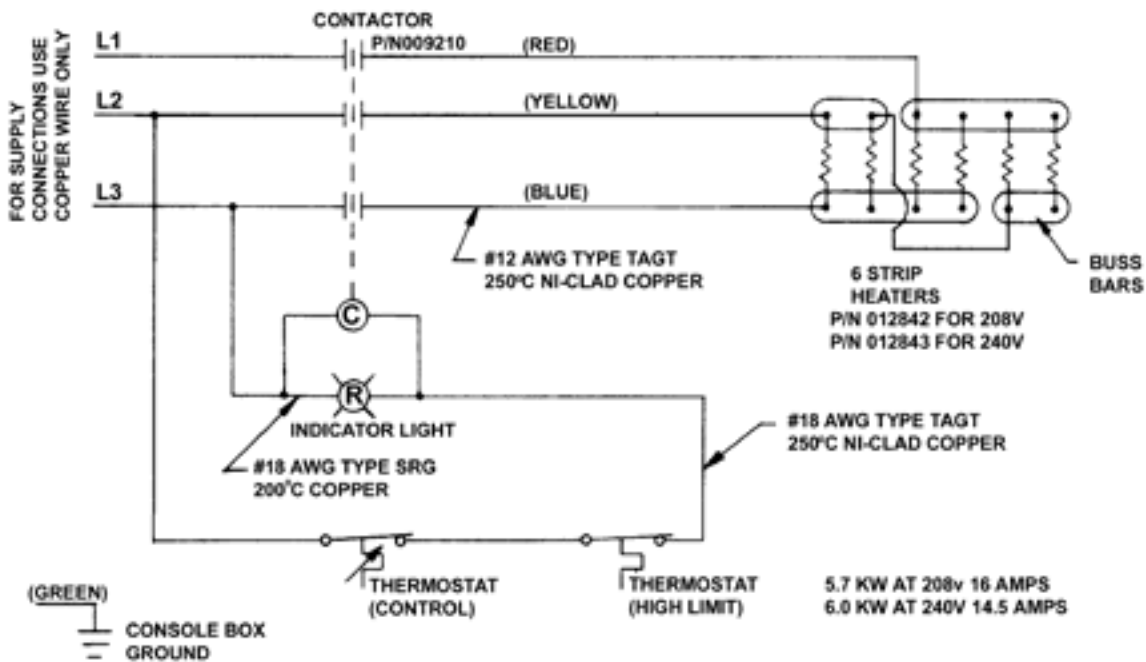

**208/240 V, 3 PH**

### Electrical Schematics

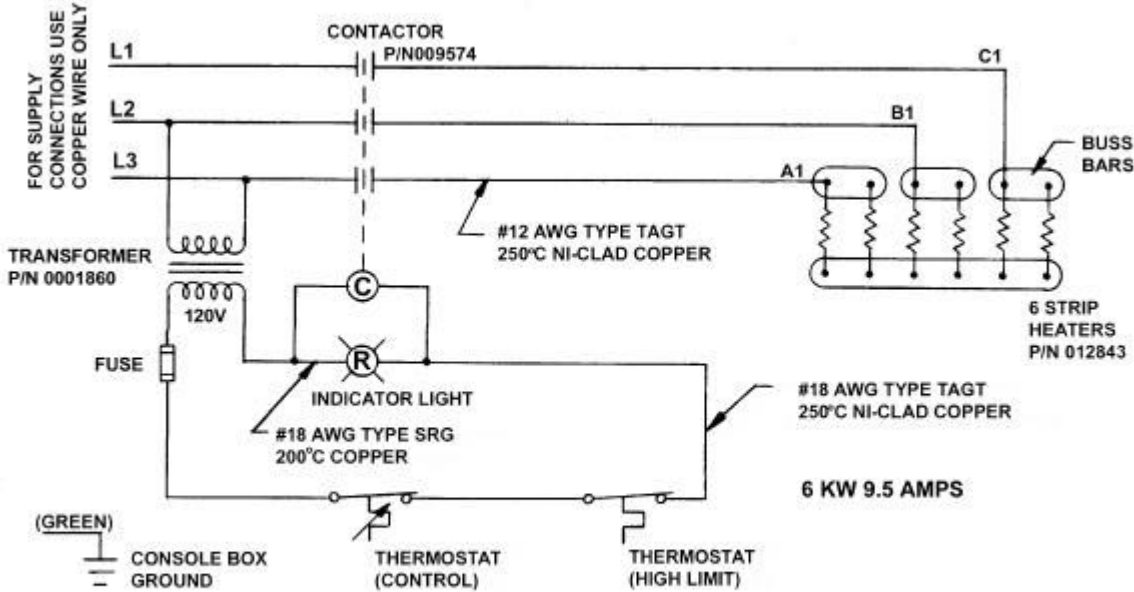

380 V, 3 PH

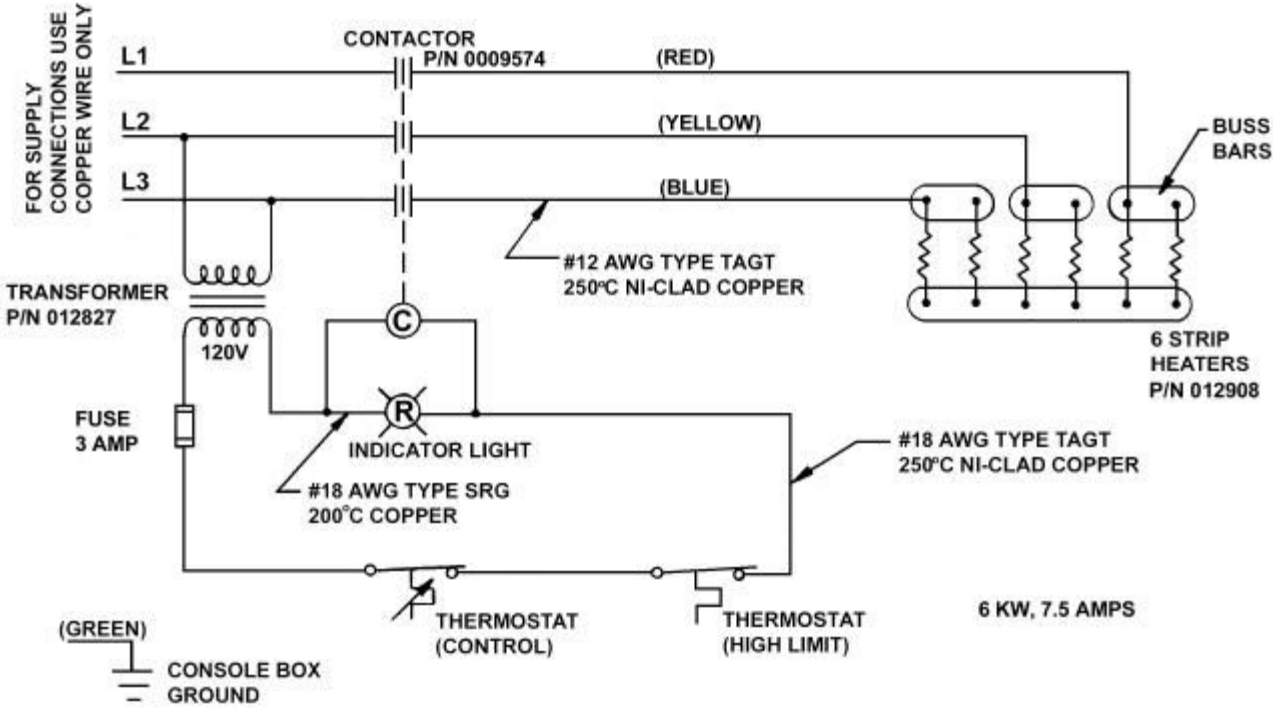

480 V, 3 PH