

# OPERATOR MANUAL

IMPORTANT INFORMATION, KEEP FOR OPERATOR

This manual provides information for:

## **TD/3 & TDA/1** *Domestic* **STEAM JACKETED KETTLE**

- Stainless Steel
- Direct Steam Heated
- Table Top Mounted
- Tilting



**THIS MANUAL MUST BE RETAINED FOR FUTURE REFERENCE. READ, UNDERSTAND AND FOLLOW THE INSTRUCTIONS AND WARNINGS CONTAINED IN THIS MANUAL.**

### **WARNING**

Do not store or use gasoline or other flammable vapors and liquids in the vicinity of this or any other appliance.

### **NOTIFY CARRIER OF DAMAGE AT ONCE**

It is the responsibility of the consignee to inspect the container upon receipt of same and to determine the possibility of any damage, including concealed damage. Unified Brands suggests that if you are suspicious of damage to make a notation on the delivery receipt. It will be the responsibility of the consignee to file a claim with the carrier. We recommend that you do so at once.

Manufacture Service/Questions 888-994-7636.

PART NUMBER 121006, REV. D (5/08)

Packaging - Processing  
**Bid on Equipment**  
1-847-683-7720  
[www.bid-on-equipment.com](http://www.bid-on-equipment.com)

# G GROEN®

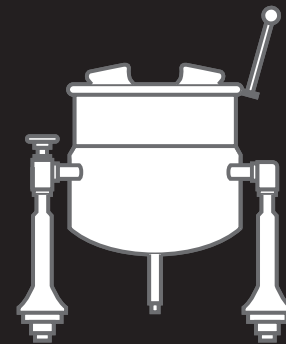

**UNIFIED BRANDS**  
FOODSERVICE EQUIPMENT SOLUTIONS  
A DOVER COMPANY

1055 Mendell Davis Drive  
Jackson, MS 39272  
888-994-7636, fax 888-864-7636  
[unifiedbrands.net](http://unifiedbrands.net)

# **IMPORTANT - READ FIRST - IMPORTANT**

- CAUTION:** BE SURE ALL OPERATORS READ, UNDERSTAND AND FOLLOW THE OPERATING INSTRUCTIONS, CAUTIONS, AND SAFETY INSTRUCTIONS CONTAINED IN THIS MANUAL.
- WARNING:** THIS UNIT IS INTENDED FOR USE IN THE COMMERCIAL HEATING, COOKING AND HOLDING OF WATER AND FOOD PRODUCTS, PER THE INSTRUCTIONS CONTAINED IN THIS MANUAL. ANY OTHER USE COULD RESULT IN SERIOUS PERSONAL INJURY OR DAMAGE TO THE EQUIPMENT AND WILL VOID WARRANTY.
- WARNING:** KETTLES MUST BE INSTALLED BY PERSONNEL QUALIFIED TO WORK WITH STEAM PLUMBING. IMPROPER INSTALLATION CAN RESULT IN INJURY TO PERSONNEL AND/OR DAMAGE TO EQUIPMENT.
- WARNING:** AVOID ANY EXPOSURE TO ESCAPING STEAM. STEAM CAN CAUSE SEVERE BURNS.
- WARNING:** TAKE EXTREME CARE TO KEEP HOT CONTENTS FROM SPILLING OR SPLASHING ON ANYONE. DO NOT STAND DIRECTLY IN FRONT OF KETTLE BODIES WHEN THEY ARE BEING TILTED.
- WARNING:** AVOID ALL DIRECT CONTACT WITH HOT EQUIPMENT SURFACES. DIRECT SKIN CONTACT COULD RESULT IN SEVERE BURNS.
- WARNING:** AVOID ALL DIRECT CONTACT WITH HOT FOOD OR WATER IN KETTLES. DIRECT CONTACT COULD RESULT IN SEVERE BURNS.
- CAUTION:** DO NOT OVER FILL THE KETTLE WHEN COOKING, HOLDING OR CLEANING. KEEP LIQUIDS AT A MINIMUM OF 2-3" (5-8 CM) BELOW THE KETTLE BODY RIM TO ALLOW CLEARANCE FOR STIRRING, BOILING AND SAFE PRODUCT TRANSFER.
- WARNING:** TAKE SPECIAL CARE TO AVOID CONTACT WITH HOT KETTLE BODY OR HOT PRODUCT WHEN ADDING INGREDIENTS, STIRRING OR TRANSFERRING PRODUCT TO ANOTHER CONTAINER.

# **IMPORTANT - READ FIRST - IMPORTANT**

**WARNING: WHEN TILTING KETTLE FOR PRODUCT TRANSFER:**

- 1) WEAR PROTECTIVE OVEN MITT AND PROTECTIVE APRON.
- 2) USE CONTAINER DEEP ENOUGH TO CONTAIN AND MINIMIZE PRODUCT SPLASHING.
- 3) PLACE CONTAINER ON STABLE, FLAT SURFACE, AS CLOSE TO KETTLE AS POSSIBLE.
- 4) STAND TO LEFT OR RIGHT SIDE OF KETTLE (DEPENDING ON TILTING HANDLE PLACEMENT) WHILE POURING. DO NOT STAND DIRECTLY IN POUR PATH OF HOT CONTENTS.
- 5) POUR SLOWLY, MAINTAIN CONTROL OF KETTLE BODY HANDLE AT ALL TIMES, AND RETURN KETTLE BODY TO UPRIGHT POSITION AFTER CONTAINER IS FILLED OR TRANSFER IS COMPLETE.
- 6) DO NOT OVER FILL CONTAINER. AVOID DIRECT SKIN CONTACT WITH HOT CONTAINER AND ITS CONTENTS.

**CAUTION: KEEP FLOORS IN FRONT OF KETTLE WORK AREA CLEAN AND DRY. IF SPILLS OCCUR, CLEAN IMMEDIATELY TO AVOID SLIPS OR FALLS.**

**WARNING: FAILURE TO CHECK SAFETY VALVE OPERATION PERIODICALLY COULD RESULT IN PERSONAL INJURY AND/OR DAMAGE TO EQUIPMENT.**

**WARNING: WHEN TESTING, AVOID AND EXPOSURE TO THE STEAM BLOWING OUT OF THE SAFETY VALVE. DIRECT CONTACT COULD RESULT IN SEVERE BURNS.**

**CAUTION: MOST CLEANERS ARE HARMFUL TO THE SKIN, EYES, MUCOUS MEMBRANES AND CLOTHING. PRECAUTIONS SHOULD BE TAKEN. WEAR RUBBER GLOVES, GOGGLES OR FACE SHIELD AND PROTECTIVE CLOTHING. CAREFULLY READ THE WARNINGS AND FOLLOW THE DIRECTIONS ON THE LABEL OF THE CLEANER TO BE USED.**

**CAUTION: USE OF ANY REPLACEMENT PARTS OTHER THAN THOSE SUPPLIED BY GROEN OR THEIR AUTHORIZED DISTRIBUTORS CAN CAUSE OPERATOR INJURY AND DAMAGE TO THE EQUIPMENT, AND WILL VOID ALL WARRANTIES.**

**WARNING: SERVICE PERFORMED BY OTHER THAN FACTORY AUTHORIZED PERSONNEL WILL VOID WARRANTIES.**

# Table of Contents

Important Operator Warnings .....	page 2
References.....	page 4
Equipment Description.....	page 5
Inspection and Unpacking .....	page 6
Installation.....	page 7
Initial Start-up.....	page 8
Operation.....	page 8
Cleaning.....	page 12
Maintenance.....	page 13
Sequence Of Operation.....	page 13
Troubleshooting.....	page 14
Parts Lists.....	page 15
Maintenance Log.....	page 18
Warranty.....	page 19

## References

KLENZADE SALES CENTER  
ECOLAB. Inc.  
370 Wabasha  
St. Paul, Minnesota 55102  
800/352-5326 or 612/293-2233

NSF INTERNATIONAL  
789 N. Dixboro Rd.  
P.O. Box 130140  
Ann Arbor, Michigan 48113-0140

ZEP MANUFACTURING CO.  
1310-T Seaboard Industrial Blvd.  
Atlanta, Georgia 30318

# Equipment Description

## A. ALL MODELS

The Groen TDC/3 and TDA/1 are tilting, table-top kettles with direct steam-heated jackets. The one-piece stainless steel body on each includes a butterfly shaped pouring lip. The kettles have a 180 emery grit interior finish and a bright semi-deluxe exterior finish.

Every unit requires a remote steam source. The steam supply is controlled by an inlet valve, and enters the jacket through one support and rotary joint. Condensate leaves the jacket through the other rotary joint and support. Standard units are ASME shop inspected, stamped, and registered with the National Board. These kettles operate efficiently at pressures above five PSI. A safety valve, strainer, steam trap, and check valve are all required for installation, and may be ordered from Groen as optional equipment.

Optional features and equipment include:

- Higher maximum pressure
- Lift-off covers
- T5C table mounting
- Bracket inserts
- Kettle brush kit
- Steam trap assembly
- Motor-driven agitator

## B. MODEL TDC/3



The TDC/3 kettle has a 2/3 jacket rated for working pressures up to 55 PSI. The kettle body incorporates a triple reinforced rim. Two tubular steel supports support the swivel on which the kettle tilts. A leg projects from the bottom of the kettle.

The design of the TDC/3 makes it easy for one person to tilt the kettle with the tilting handle, even when the kettle is full.

Model	Capacity	Dimensions: Inches (mm)		
	Quarts (liters)	Front to Back	Left to Right	Rim Height
TDC/3-10	10 (9.4)	13-1/4 (337)	12-7/8 (327)	16-1/8 (410)
TDC/3-20	20 (18.9)	15-1/4 (387)	14-7/8 (378)	17-1/8 (435)

## C. MODEL TDA/1



The TDA/1 kettle incorporates a triple reinforced rim and a 2/3 jacket registered for working pressures up to 50 PSI. Two chrome-plated arms support the trunnions on which the kettle tilts. The arm that also serves as the steam inlet has an integral steam control valve.

Model	Capacity	Dimensions: Inches (mm)		
	Quarts (liters)	Front to Back	Left to Right	Rim Height
TDA/1-40	40 (37.8)	19-3/4 (502)	26-3/4 (679)	22-3/8 (568)

# Inspection & Unpacking

## CAUTION

AVOID NAILS AND SPLINTERS WHEN REMOVING KETTLES FROM WOODEN CRATES. WEAR SAFETY GLASSES.

## CAUTION

UNIT WEIGHS 40 TO 125 LBS (18 TO 61 KG). FOR SAFE HANDLING, INSTALLER SHOULD GET HELP AS NEEDED, OR USE MATERIALS HANDLING EQUIPMENT (e.g., FORT LIFT, DOLLY OR PALLET JACK) TO REMOVE THE UNIT FROM THE SKID AND PLACE IT FOR INSTALLATION.

When installation is to begin, cut the straps holding the unit on the skid. Lift the unit straight up off of the skid.

## CAUTION

SHIPPING STRAPS ARE UNDER TENSION AND CAN SNAP BACK WHEN CUT.

The kettle will arrive completely assembled and wrapped in protective plastic, strapped and bolted on a skid, enclosed in a cardboard crate. Immediately on receipt remove the box and plastic wrap, and inspect the unit for damage. Report any damage or an incorrect shipment to the delivery agent.

Write down the model number, serial number and installation date, and keep this information for future reference. Space for these entries is provided at the top of the Service Log in the back of this manual.

# Installation

**WARNING**  
**THIS UNIT MUST BE INSTALLED BY PERSONNEL QUALIFIED TO WORK WITH PLUMBING. IMPROPER INSTALLATION CAN CAUSE INJURY TO PERSONNEL AND/OR DAMAGE TO EQUIPMENT.**

1. Installation under a ventilation hood is recommended. Consult local codes.
2. Install and anchor the kettle on a level and rigid surface. Recommended mounting surface is 16 gauge (.060" thick) top with a lower reinforcement of C4 structural channel. NOTE: Failure to install the kettle per above recommendation may cause the steam piping to flex and leak, reduce seal life and will void warranty.
3. If the steam supply pressure is greater than the maximum working pressure stamped on the nameplate, you must install a pressure reducing valve in the steam supply line near the kettle.
4. Connect the steam supply line to the steam inlet fitting. Include a steam control valve and an appropriate safety valve. To obtain the full heating capability of the kettle, the steam supply line must be as large as the steam inlet fitting.
5. The safety valve is preset to relieve jacket pressure that exceeds its rated limit. Do not try to adjust the valve setting, and do not allow the valve outlet or lever to be blocked.
6. Connect the kettle condensate return line to the boiler return line, or to a drain. A suitable steam trap, strainer, and check valve must be installed. (See piping diagram, below).
7. Any mechanical change must be approved by the Groen Service Department.

## STANDARD PIPING FOR TDC/3 & TDA/1

The inlet valve may be located anywhere on the cabinet top or face but not through the face casting. The illustrated sleeve is designed to simplify valve installation by allowing the valve to shift off center by 1/4", if necessary. This should be enough to allow for thread take-up and misalignment.

\*Accessories available from Groen as options. Piping is to be supplied by the installer.

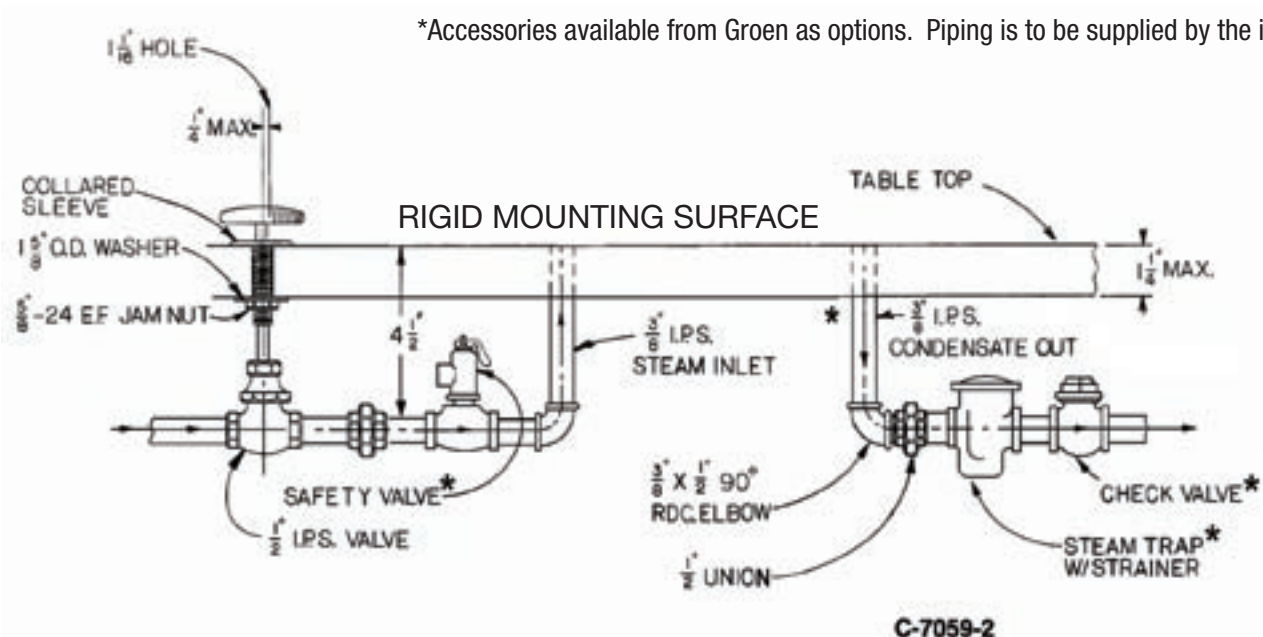

# Initial Start-Up

**IMPORTANT**  
**BE SURE ALL OPERATORS READ,**  
**UNDERSTAND AND FOLLOW THE OPERATING**  
**INSTRUCTIONS, CAUTIONS, AND SAFETY**  
**INSTRUCTIONS CONTAINED IN THIS**  
**MANUAL.**

**WARNING**  
**AVOID ANY EXPOSURE TO ESCAPING STEAM,**  
**WHICH CAN CAUSE SEVERE BURNS.**



Now that the kettle has been installed, you should test it to ensure that it is operating correctly.

1. Remove all literature and packing materials from inside and outside of the unit.
2. Pour a small amount of water into the kettle.
3. Open the steam inlet valve.
4. When the water begins to boil, inspect all of the fittings to ensure that there are no leaks.
5. Check the safety valve by lifting its lever far enough to let steam escape. Then let it snap back into place to reset the valve so that it will not leak.
6. Shut down the unit by closing the steam inlet valve.
7. Operate the tilting mechanism to confirm that this feature functions through the whole range of normal operation.

If the unit functions as described above, it is ready for use. If the unit does not function as intended, contact your local Groen Certified Service Agency.

# Operation

**WARNING**  
AVOID EXPOSURE TO ESCAPING STEAM,  
WHICH CAN CAUSE SEVERE BURNS.

**CAUTION**  
KEEP FLOORS IN FRONT OF THE KETTLE  
WORK AREA CLEAN AND DRY. IF SPILLS  
OCCUR, CLEAN AT ONCE TO AVOID SLIPS  
OR FALLS.

**WARNING**  
AVOID ALL DIRECT CONTACT WITH HOT  
FOOD OR WATER IN THE KETTLE. DIRECT  
CONTACT COULD RESULT IN SEVERE BURNS.

TAKE SPECIAL CARE TO AVOID CONTACT  
WITH HOT KETTLE BODY OR HOT PRODUCT  
WHEN ADDING INGREDIENTS, STIRRING,  
OR TRANSFERRING PRODUCT TO ANOTHER  
CONTAINER.

**CAUTION**  
DO NOT OVER FILL THE KETTLE WHEN  
COOKING, HOLDING OR CLEANING. KEEP  
LIQUIDS AT A MINIMUM OF 2-3" (5-8 CM)  
BELOW THE KETTLE BODY RIM TO ALLOW  
CLEARANCE FOR STIRRING, BOILING AND  
SAFE PRODUCT TRANSFER.

**WARNING**  
WHEN TILTING KETTLE FOR PRODUCT  
TRANSFER:

- 1) WEAR PROTECTIVE OVEN MITT AND  
PROTECTIVE APRON.
- 2) USE CONTAINER DEEP ENOUGH TO  
CONTAIN AND MINIMIZE PRODUCT  
SPLASHING.
- 3) PLACE CONTAINER ON STABLE, FLAT  
SURFACE, AS CLOSE TO KETTLE AS  
POSSIBLE.
- 4) STAND TO LEFT OR RIGHT SIDE OF  
KETTLE (DEPENDING ON TILTING HANDLE  
PLACEMENT) WHILE POURING. DO NOT  
STAND DIRECTLY IN POUR PATH OF HOT  
CONTENTS.
- 5) POUR SLOWLY, MAINTAIN CONTROL OF  
KETTLE BODY HANDLE AT ALL TIMES,  
AND RETURN KETTLE BODY TO UPRIGHT  
POSITION AFTER CONTAINER IS FILLED OR  
TRANSFER IS COMPLETE.
- 6) DO NOT OVER FILL CONTAINER. AVOID  
DIRECT SKIN CONTACT WITH HOT  
CONTAINER AND ITS CONTENTS.

To heat the kettle, open the steam inlet valve. Adjusting the valve allows you to control the heating rate. Opening the valve more allows steam to flow into the jacket faster, and heats the product faster.

The kettle operates efficiently at pressures from five PSI to the maximum working pressure for which the kettle was designed. The maximum pressure is stamped on the kettle nameplate.

## TILTING

To transfer product or empty the kettle: the kettle is designed and manufactured to be tilted in a controlled manner. Grasp the insulated plastic ball firmly. Maintain a firm grip on handle when tilting, while keeping the kettle body in a tilted position and then SLOWLY returning the kettle body to an upright position.



# Operation

## ACCESSORIES

**CAUTION**  
DO NOT TILT KETTLE BODY WITH COVER IN PLACE. COVER MAY SLIDE OFF, CAUSING INJURY TO OPERATOR.

**WARNING**  
AVOID ALL DIRECT CONTACT WITH HOT SURFACES. DIRECT SKIN CONTACT COULD RESULT IN SEVERE BURNS.

AVOID ALL DIRECT CONTACT WITH HOT FOOD OR WATER IN THE KETTLE. DIRECT CONTACT COULD RESULT IN SEVERE BURNS.

**CAUTION**  
DO NOT OVERFILL THE KETTLE WHEN COOKING, HOLDING OR CLEANING. KEEP LIQUIDS A MINIMUM OF 2-3" (5-8 CM) BELOW THE KETTLE RIM TO ALLOW CLEARANCE FOR STIRRING, BOILING AND SAFE PRODUCT TRANSFER.



AVOID CONTACT WITH STEAM AND HOT CONDENSATE WHEN REMOVING A COVER.



### 1. Cover

As with stock pot cooking, an optional lift-off cover can speed up the heating of water and food products. A cover helps retain heat in the cooking vessel and reduces the amount of heat and humidity released into the kitchen. Use of a cover can reduce some product cook times and help maintain the temperature, color and texture of products being held or simmered for extended periods.

Make sure plastic ball handle is secure on the lift off cover before using. ALWAYS use the plastic handle to place or remove the cover from the kettle. Wear protective oven mitts and a protective apron.

When putting the cover on the kettle, position it on top of kettle rim, with its flat edge facing the pouring lip.

When removing cover:

- a) Firmly grasp the plastic handle
- b) Lift rear edge (farthest from operator) 1-2" (3-5 cm) to allow any steam and water vapor to escape the cooking vessel. Wait 2-3 seconds.
- c) Tilt cover to 45-60° angle and allow any hot condensate or product to roll off cover back into kettle.
- d) Remove the cover, ensuring that any remaining hot condensate or product does not drip on operator, floor or work surfaces.
- e) Place cover on safe, flat, sanitary, out-of-the-way surface, or return to kettle rim.

# Operation

## ACCESSORIES Continued...

### WARNING

AVOID ALL DIRECT CONTACT WITH HOT SURFACES. DIRECT SKIN CONTACT COULD RESULT IN SEVERE BURNS.

AVOID ALL DIRECT CONTACT WITH HOT FOOD OR WATER IN THE KETTLE. DIRECT CONTACT COULD RESULT IN SEVERE BURNS.

### CAUTION

DO NOT OVERFILL THE KETTLE WHEN COOKING, HOLDING OR CLEANING. KEEP LIQUIDS A MINIMUM OF 2-3" (5-8 CM) BELOW THE KETTLE RIM TO ALLOW CLEARANCE FOR STIRRING, BOILING AND SAFE PRODUCT TRANSFER.

### WARNING

**HOT SURFACES**



## 2. Basket Insert

An optional kettle basket insert (10 Quart and larger) can assist in cooking water boiled products, including eggs, potatoes, vegetables, shell fish, pasta and rice. The nylon mesh liner must be used when cooking product smaller than the mesh size of the basket, which is approximately 1/4" (6 mm). This includes rice and small pasta shapes.

Allow for the water displacement of basket and product to be cooked. This may mean only filling the kettle half full of water. Test the basket and product displacement with the kettle OFF, and with cold water in the kettle.

- a) Load basket on a level, stable work surface.
- b) Lift the loaded basket with both hands. Get help from another person if the basket is too heavy for safe handling.
- c) Slowly lower product into kettle.
- d) When removing basket with cooked product, lift the basket straight up, ensuring that the bottom of the basket clears the rim and pouring lip of the kettle. Wear protective oven mitts and a protective apron.
- e) Allow hot water to fully drain from product before moving the basket away from the kettle. Do not rest the kettle basket on the kettle rim or pouring lip. If the basket is too heavy for one individual to lift and safely move, get help from another person. Remove product immediately from the basket into another container, being sure to avoid contact with hot product and hot basket or . .
- f) Place basket with food on stable, flat surface, setting it inside a solid steamer or bake pan, to catch any remaining hot water which might drain from product.

# Cleaning

**CAUTION**  
MOST CLEANERS ARE HARMFUL TO THE SKIN, EYES, MUCOUS MEMBRANES AND CLOTHING. PRECAUTIONS SHOULD BE TAKEN. WEAR RUBBER GLOVES, GOGGLES OR FACE SHIELD AND PROTECTIVE CLOTHING. CAREFULLY READ THE WARNINGS AND FOLLOW THE DIRECTIONS ON THE LABEL OF THE CLEANER TO BE USED.

**WARNING**  
AVOID ANY DIRECT CONTACT WITH HOT SURFACES. DIRECT SKIN CONTACT COULD RESULT IN SEVERE BURNS.



USE BRUSHED, SPONGES OR CLOTH TO CLEAN YOUR KETTLES

**CAUTION**  
NEVER LEAVE A CHLORINE SANITIZER IN CONTACT WITH STAINLESS STEEL SURFACES LONGER THAN 30 MINUTES. LONGER CONTACT CAN CAUSE STAINING AND CORROSION.



DON'T SCRAPE WITH TOOLS, STEEL WOOL OR OTHER ABRASIVES

1. Suggested Tools:
  - a) A good cleaner
  - b) Kettle brushes in good condition
  - c) A good sanitizer
  - d) Film remover
2. Procedure:
  - a) Clean food-contact surfaces as soon as possible after use. If the unit is in continuous use, thoroughly clean and sanitize the interior and exterior at least once every 12 hours.
  - b) Scrape and flush out food residues. Be careful not to scratch the kettle with metal implements.
  - c) Prepare a hot solution of the detergent/ cleaning compound as instructed by the supplier.
  - d) Clean the unit thoroughly, inside and outside.
  - e) Rinse the kettle thoroughly with hot water, then drain completely.
  - f) As part of the daily cleaning program, clean soiled external and internal surfaces.
  - g) To remove stuck materials, use a brush, sponge, cloth, plastic or rubber scraper, or plastic wool with the cleaning solution. To reduce effort required in washing, let the detergent solution sit in the kettle and soak into the residue. Do not use abrasive materials or metal tools that might scratch the surface. Scratches make the surface harder to clean and provide places for bacteria to grow.
  - h) Do not use steel wool, which may leave particles in the surface and cause eventual corrosion and pitting.
  - i) The outside of the unit may be polished with a stainless steel cleaner such as "Zepper" from Zep Manufacturing Co.
  - j) When equipment needs to be sanitized, use a solution equivalent to one that supplies 200 parts per million available chlorine. Obtain advice on sanitizing agents from your supplier of sanitizing products.
  - k) Following the supplier's instructions, apply the agent after the unit has been cleaned and drained. Drain and thoroughly rinse off the sanitizer.
  - l) It is recommended that each piece of equipment be sanitized just before use.
  - m) If there is difficulty removing mineral deposits or a film left by hard water or food residues, clean the kettle thoroughly and use a deliming agent, such as Groen Delimer/Descaler (Part Number 114800) or Lime-Away® from Ecolab, in accordance with the manufacturer's directions. Rinse and drain the unit thoroughly before further use.
  - n) If cleaning problems persist, contact your cleaning product representative for assistance. The supplier has a trained technical staff with laboratory facilities to serve you.

# Maintenance

## PERIODIC MAINTENANCE

**CAUTION**  
USE OF ANY REPLACEMENT PARTS OTHER THAN THOSE SUPPLIED BY GROEN OR AN AUTHORIZED SUPPLIER WILL VOID ALL WARRANTIES AND COULD INJURE THE OPERATOR OR DAMAGE THE EQUIPMENT.

**WARNING**  
WHEN TESTING, AVOID ANY EXPOSURE TO THE STEAM BLOWING OUT OF THE SAFETY VALVE. DIRECT CONTACT COULD RESULT IN SEVERE BURNS.



**NOTICE:** Contact Groen or an authorized Groen representative when repairs are required.

A Maintenance and Service Log is provided at the back of this manual. Each time maintenance is performed on your Groen kettle, enter the date on which the work was done, what was done, and who did it. File the log with the warranty.

Periodic inspection will minimize equipment down time and increase the efficiency of operation. The following points should be checked:

- 1) Once a day, with pressure in the jacket, check the operation of the safety valve. Lift the lever of the safety valve until steam is released. Then release the lever and let the valve snap shut. If the lever does not activate, or there is no evidence of discharge, or the valve leaks, immediately discontinue use of the kettle and contact a qualified Groen service representative.
- 2) At least once every 90 days, inspect fittings and valves for signs of damage or wear. Regularly examine trunnion packings and valve seats for wear, and replace them when necessary.

**NOTE:** Service performed by other than factory authorized personnel will void all warranties.

- 3) Lubricate trunnions and gears with a good grade of high temperature grease. Grease trunnions at least once every 60 days, and grease gears when inspection shows that they are dry.

## SEQUENCE OF OPERATION

The following "action-reaction" outline is provided to help the user understand the function of the equipment.

When the steam inlet valve is opened, steam flows into the jacket at a pressure determined by the boiler system or by the pressure reducing valve that serves the kettle.

In the jacket, steam transfers heat to the kettle as it condenses into water. The steam trap allows condensate (water) to leave the jacket, while it holds steam in. When the steam is shut off, condensation produces a vacuum in the jacket, but the check valve in the condensate return line keeps water from flowing back into the jacket.

# Troubleshooting

**WARNING**  
**USE OF ANY REPLACEMENT PARTS OTHER THAN THOSE SUPPLIED BY GROEN OR AN AUTHORIZED SUPPLIER/DISTRIBUTOR WILL VOID ALL WARRANTIES AND COULD INJURE THE OPERATOR OR DAMAGE THE EQUIPMENT.**

**WARNING**  
**TO AVOID INJURY FROM SPLASHING OR SPILLING HOT CONTENTS, EMPTY THE KETTLE THROUGH THE DRAWOFF OR BY BAILING BEFORE ANY WORK IS DONE ON THE TILTING MECHANISM.**

Your Groen kettle will operate smoothly and efficiently if properly maintained. However, the following is a list of checks to make in the event of a problem. If the actions suggested do not solve the problem, call your qualified Groen Service Representative. For the phone number of the nearest agency, call your area Groen representative or the Groen Parts and Service Department. If an item on the list is followed by X, the work should be done by a qualified service representative.

SYMPTOM	WHO	WHAT TO CHECK X indicates items which must be performed by an authorized technician.
Kettle will not heat.	User	a. That the steam inlet valve is open. b. That the steam supply line is turned on. c. That the condensate return valve is open. d. That the boiler is operating properly. Steam should be supplied at a pressure greater than five PSI.
	Auth Service Rep Only	e. Steam supply line for blockage. X f. Condensate return line for blockage. X g. Steam trap operation. X
Safety valve leaks a small amount of steam.	User	a. For contamination that prevents seating the valve. With pressure in the jacket, lift the valve lever briefly all the way up, to blow the valve clean then let it snap back down to seat the valve.
	Auth Service Rep Only	b. Safety valve for defects. Defective valve <b>MUST</b> be replaced with an identical valve. X
Safety valve leaks a large amount of steam.	Auth Service Rep Only	a. Steam supply pressure. X b. Safety valve for defects. Defective valve <b>MUST</b> be replaced with an identical valve. X
Pipe fitting leaks.	User	a. Is the fitting tight?
	Auth Service Rep Only	b. If the leak is at a trunnion, and tightening the packing gland does not stop the leak, replace the packing. X

# Parts List Model TDC/3

Key	Description	Part No.
1	Pedestal Assembly	081572
2	Pedestal Cap	081574
3	Nut, Hex Jam 1-3/4" OD	081707
7	Packing Ring Set	002033
8	Washer Packing	002019
9	Spring	002025
10	Washer 5/8" Neoprene	003242
11	Tip, Crutch 1" ID	002032
12	Handle Assembly	012694
13	Knob, Maroon Ball	012691
14	Ring, Tolerance	012692
15	Handle Shaft	018963
16	Lockwasher 3/8"	005618
17	Nut Cap 3/8-24	003188
18	Basket TDC/3-10	001110
19	Basket TDC/3-20	001120
20	Cover Assembly TDC/3-10	001107
21	Cover Assembly TDC/3-20	001108
22	Valve, Globe 3/8" Brass	002051
23	Valve, Globe 3/8" RCP	010145
24	Valve, Globe 3/8" PCP	010146
25	Handwheel, Valve	01148
26	Valve, Safety (not incl.)	011001
27	Strainer, 1/2" Blk	004181
28	Strainer, 1/2" RCP	010165
29	Strainer, 1/2" PCP	010166
30	Steam Trap Repair Kit	002886
31	Steam Trap, 1/2" Blk	010250
32	Steam Trap, 1/2" RCP	010251
33	Steam Trap, 1/2" PCP	010252
34	Valve, Check 1/2" Brass	004187
35	Valve, Check 1/2" RCP	010124
36	Valve, Check 1/2" PCP	010140
37	Nipple, 3/8" x 12-1/2" Lg	005485
--	Pedestal Gasket (old style)	001968
--	Bullet Foot	042505
--	Stem Extension PCP	012722
--	Kettle Body	MS2043
--	Control, DC Adjustable	013972
--	Control, DC Adjustable	005125

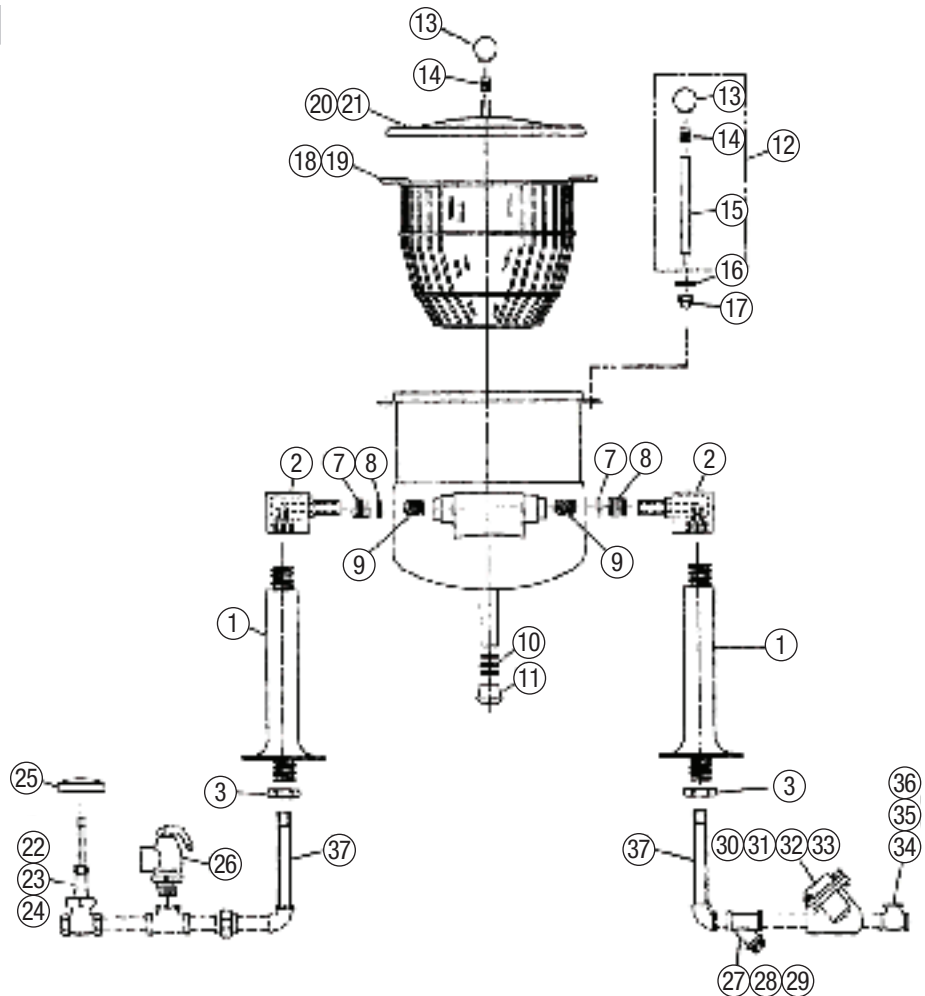

# Parts List Model TDA

Key	Description	Part No.
1	Knob	001385
2	Handle & Bushing Assy.	001022
3	Spring	001067
4	Handle Guide Nut	001025
5	Plunger Guide	001046
6	Elbow Assembly (incl. item 5) see 6a	001083
6a	Elbow Assembly- 1,4,6 Qt pre 1957	001043
7	O-Ring	007360
8	Hex Nut (see 8a)	001032
8a	Hex Nut 1,4,6 Qt pre 1957	001034
9	Ferrule	001023
10	Pedestal (to 20 Qts incl)	001087
10a	Pedestal (40 Qt size only)	001088
11	Hex Mounting Nut	001031
12	Pipe (for 1087 Pedestal)	001056
12a	Pipe (for 1088 Pedestal)	001057
13	Packing	001065
14	Packing Gland (see 14a)	001036
14a	Packing Gland-1,4,6 sizes pre 1957	001045
15	Valve Assembly (incl. 16,17,18,19,20) see 15a	001037
15a	Valve Assy-1,4,6 Qt pre 1957	001042
16	Stem Assembly	001098
16a	Stem Ass-1,4,6 Qt pre 1957	002076
17	Bonnet, see 17a	001142
17a	Bonnet-1,4,6 Qt pre 1957	001075
18	Packing Ring	001152
19	Packing Nut	001144
20	Handle (small 2" dia)	001148
21	Basket TDA 10	001110
21a	Basket TDA 20	001120
22	Cover TDA 10	001107
22a	Cover TDA 20	001108
23	Safety Valve (state pressure)	--
24	1/2" Strainer	004181
25	1/2" Steam Trap	004182
26	1/2" Swing Check Valve	004187
27	Handle Screw	002613
28	Valve Stem Assembly (incl. 16,17,18,19,20,27)	002615

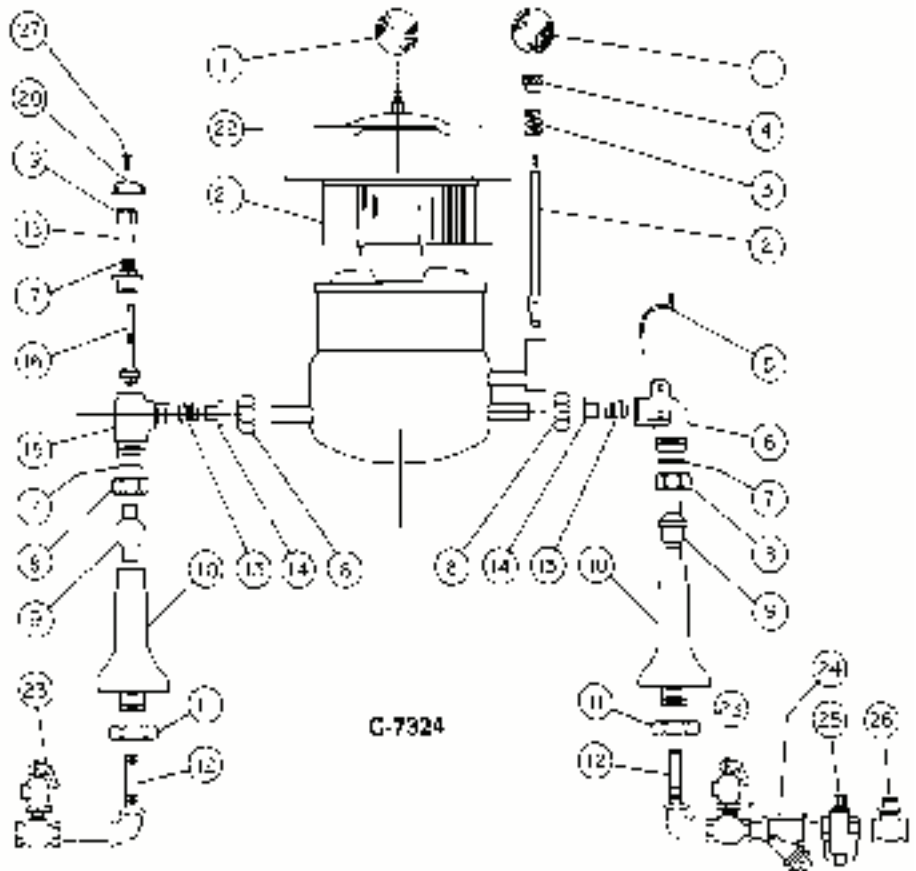

\* Obsolete, see item 28

# Diagram - Trunnion Packings for Model TDC/3

NOTE: THESE 5 RINGS COMPRISE ONE SET  
OF PACKING & MUST BE ASSEMBLED IN  
THE MANNER SHOWN. PART NO 2033

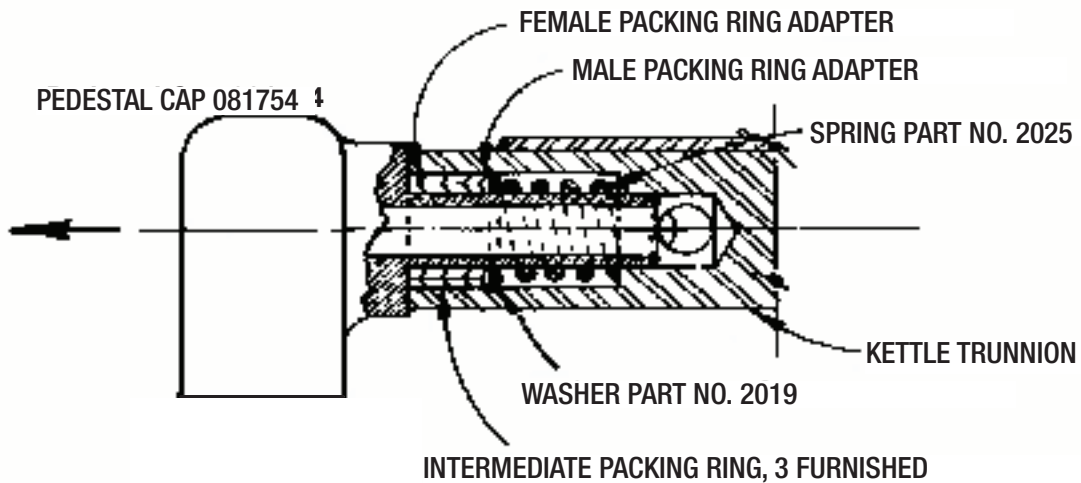

A-5758