

OPERATOR MANUAL & SERVICE MANUAL

IMPORTANT INFORMATION, KEEP FOR OPERATOR

This manual provides information for:

MODELS TA/3 *Domestic* **INCLINED MIXER** **ASSEMBLY**

- Stainless Steel
- Tilt-Out Drive System
- Speed Agitator Controls
- For 40, 60 & 80 Gallon Kettles

DEE 4/T - (40, 60) TA/3

DHT - (40, 60) TA/3

D - (40, 60) TA/3



**THIS MANUAL MUST BE RETAINED FOR FUTURE REFERENCE.
READ, UNDERSTAND AND FOLLOW THE INSTRUCTIONS AND
WARNINGS CONTAINED IN THIS MANUAL.**

WARNING

Do not store or use gasoline or other flammable vapors and liquids in the vicinity of this or any other appliance.

NOTIFY CARRIER OF DAMAGE AT ONCE

It is the responsibility of the consignee to inspect the container upon receipt of same and to determine the possibility of any damage, including concealed damage. Unified Brands suggests that if you are suspicious of damage to make a notation on the delivery receipt. It will be the responsibility of the consignee to file a claim with the carrier. We recommend that you do so at once.

Manufacture Service/Questions 888-994-7636.

Information contained in this document is known to be current and accurate at the time of printing/creation. Unified Brands recommends referencing our product line websites, unifiedbrands.net, for the most updated product information and specifications.

PART NUMBER 141909, REV. B (7/06)

G GROEN®

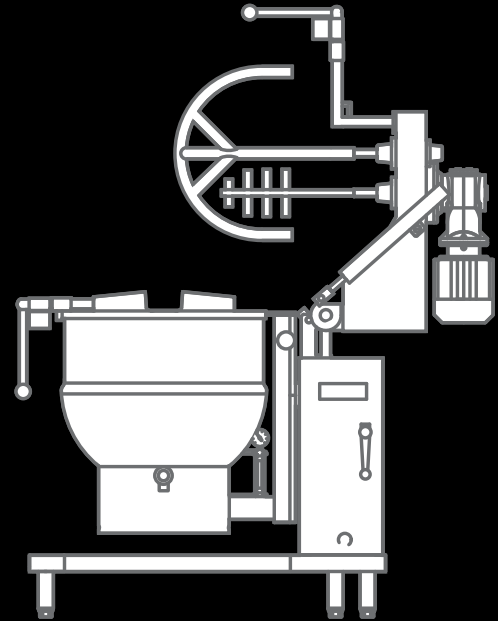

1055 Mendell Davis Drive
Jackson, MS 39272
888-994-7636, fax 888-864-7636
groen.com

IMPORTANT — READ FIRST — IMPORTANT

- CAUTION:** BE SURE ALL OPERATORS READ, UNDERSTAND AND FOLLOW THE OPERATING INSTRUCTIONS, CAUTIONS, AND SAFETY INSTRUCTIONS CONTAINED IN THIS MANUAL.
- WARNING:** THIS UNIT IS INTENDED FOR USE IN THE COMMERCIAL HEATING, COOKING AND HOLDING OF WATER AND FOOD PRODUCTS, PER THE INSTRUCTIONS CONTAINED IN THIS MANUAL. ANY OTHER USE COULD RESULT IN SERIOUS PERSONAL INJURY OR DAMAGE TO THE EQUIPMENT AND WILL VOID WARRANTY.
- WARNING:** THE KETTLE MUST BE INSTALLED BY PERSONNEL QUALIFIED TO WORK WITH ELECTRICITY. IMPROPER INSTALLATION CAN RESULT IN INJURY TO PERSONNEL AND/OR DAMAGE TO EQUIPMENT.
- DANGER:** ELECTRICALLY GROUND THE UNIT AT THE TERMINAL PROVIDED. FAILURE TO GROUND UNIT COULD RESULT IN ELECTROCUTION AND DEATH.
- WARNING:** AVOID ALL DIRECT CONTACT WITH HOT EQUIPMENT SURFACES. DIRECT SKIN CONTACT COULD RESULT IN SEVERE BURNS.
- WARNING:** AVOID ALL DIRECT CONTACT WITH HOT FOOD OR WATER IN THE KETTLE. DIRECT CONTACT COULD RESULT IN SEVERE BURNS.
- CAUTION:** DO NOT OVER FILL THE KETTLE WHEN COOKING, HOLDING OR CLEANING. KEEP LIQUIDS A MINIMUM OF 2-3" (5-8 cm) BELOW THE KETTLE BODY RIM TO ALLOW CLEARANCE FOR STIRRING, BOILING AND SAFE PRODUCT TRANSFER.
- WARNING:** TAKE SPECIAL CARE TO AVOID CONTACT WITH HOT KETTLE BODY OR HOT PRODUCT WHEN ADDING INGREDIENTS, STIRRING OR TRANSFERRING PRODUCT TO ANOTHER CONTAINER.
- WARNING:** DO NOT STAND ON OR APPLY UNNECESSARY WEIGHT OR PRESSURE ON THE KETTLE FRONT OR POURING LIP. THIS COULD RESULT IN OVERLOAD AND FAILURE OF THE TILT MECHANISM, AND POSSIBLE SERIOUS INJURY AND BURNS TO THE OPERATOR AND OTHERS.
- WARNING:** WHEN TILTING KETTLE FOR PRODUCT TRANSFER:
- 1) WEAR PROTECTIVE OVEN MITT AND PROTECTIVE APRON.
 - 2) USE CONTAINER DEEP ENOUGH TO CONTAIN AND MINIMIZE PRODUCT SPLASHING.
 - 3) PLACE CONTAINER ON STABLE, FLAT SURFACE, AS CLOSE TO THE KETTLE AS POSSIBLE.
 - 4) STAND TO LEFT OR RIGHT SIDE OF KETTLE (DEPENDING ON TILTING HANDLE PLACEMENT) WHILE POURING. DO NOT STAND DIRECTLY IN POUR PATH OF HOT CONTENTS.
 - 5) POUR SLOWLY, MAINTAIN CONTROL OF KETTLE BODY HANDLE AT ALL TIMES, AND RETURN KETTLE BODY TO UPRIGHT POSITION AFTER CONTAINER IS FILLED OR TRANSFER IS COMPLETE.
 - 6) DO NOT OVER FILL CONTAINER. AVOID DIRECT SKIN CONTACT WITH HOT CONTAINER AND ITS CONTENTS.
- CAUTION:** KEEP FLOORS IN FRONT OF KETTLE WORK AREA CLEAN AND DRY. IF SPILLS OCCUR, CLEAN IMMEDIATELY, TO AVOID SLIPS OR FALLS.
- WARNING:** FAILURE TO CHECK PRESSURE RELIEF VALVE OPERATION PERIODICALLY COULD RESULT IN PERSONAL INJURY AND/OR DAMAGE TO EQUIPMENT.
- WARNING:** WHEN TESTING, AVOID ANY EXPOSURE TO THE STEAM BLOWING OUT OF THE PRESSURE RELIEF VALVE. DIRECT CONTACT COULD RESULT IN SEVERE BURNS.
- WARNING:** TO AVOID INJURY, READ AND FOLLOW ALL PRECAUTIONS STATED ON THE LABEL OF THE WATER TREATMENT COMPOUND.
- WARNING:** BEFORE REPLACING ANY PARTS, DISCONNECT THE UNIT FROM THE ELECTRIC POWER SUPPLY.
- WARNING:** TURN OFF POWER AT THE CIRCUIT BREAKER PRIOR TO INSTALLATION OR SERVICE.

- WARNING:** THE MIXER MUST BE INSTALLED BY PERSONNEL WHO ARE QUALIFIED TO WORK WITH ELECTRICITY, IMPROPER INSTALLATION CAN RESULT IN INJURY TO PERSONNEL AND/OR DAMAGE TO EQUIPMENT.
- WARNING:** ANY MECHANICAL OR ELECTRICAL CHANGE MUST BE APPROVED BY THE GROEN FOOD SERVICE ENGINEERING DEPARTMENT.
- WARNING:** TURN OFF AGITATOR BEFORE ADDING INGREDIENTS OR INSPECTING KETTLE CONTENTS. DO NOT WEAR LOOSE CLOTHING OR JEWELRY AROUND OPERATING MIXER KETTLE. KEEP WELL CLEAR OF ROTATING MIXER ARMS AND PADDLES AT ALL TIMES.
- WARNING:** THE UNIT IS EQUIPPED WITH AN AUTOMATIC CUTOFF SWITCH. IF POWER IS ON WHEN A TILTED MIXER IS LOWERED INTO THE OPERATING POSITION, THE MIXER WILL AUTOMATICALLY START.
- CAUTION:** STARTING WITH THE MIXER SET AT HIGH SPEED MAY CAUSE MATERIAL TO SPILL OUT OF THE KETTLE ON TWO SPEED AND VARIABLE SPEED UNITS.
- CAUTION:** UNDER HEAVY LOAD DO NOT RUN THE MIXER CONTINUOUSLY AT SLOWER THAN 5% OF FULL SPEED. SLOWER OPERATION COULD DAMAGE THE SPEED CONTROL.
- WARNING:** BEFORE CLEANING ANY PART OF THE MIXER, OTHER THAN THE AGITATOR, DISCONNECT THE ELECTRICAL SUPPLY AT THE CIRCUIT BREAKER OR FUSE BOX TO AVOID POSSIBLE ELECTRICAL SHOCK.
- WARNING:** KEEP WATER AND SOLUTIONS OUT OF THE CONTROLS, ELECTRICAL WIRING, AND DRIVE MECHANISM. NEVER SPARY OR HOSE THE MIXER.
- CAUTION:** WHEN YOU INSTALL THE SCRAPER BLADES, MAKE SURE THE SCRAPER IS CURVED. A REVERSED SCRAPER WILL NOT SCRAPE AND CAN CAUSE SERIOUS DAMAGE.
- WARNING:** AVOID CONTACT WITH CLEANING PRODUCTS IN ACCORDANCE WITH SUPPLIER AND MANUFACTURER RECOMMENDATIONS. MANY CLEANERS ARE HARMFUL TO THE SKIN, EYES, MUCOUS MEMBRANES AND CLOTHING. READ THE WARNINGS AND FOLLOW DIRECTIONS ON THE CLEANER LABEL.
- WARNING:** USE OF ANY REPLACEMENT PARTS OTHER THAN THOSE SUPPLIED BY GROEN OR THEIR AUTHORIZED DISTRIBUTOR VOIDS ALL WARRANTIES AND CAN CAUSE BODILY INJURY TO THE OPERATOR AND DAMAGE TO THE EQUIPMENT.
- WARNING:** SERVICE PERFORMED BY OTHER THAN FACTORY AUTHORIZED PERSONNEL WILL VOID ALL WARRANTIES.
- WARNING:** BEFORE REPLACING ANY PARTS, SHUT OFF ALL ELECTRIC POWER SUPPLIES TO THE COOKER/MIXER.
- WARNING:** USE ONLY GROEN-SUPPLIED PARTS. SUBSTITUTION OF UNAUTHORIZED OR GENERIC PARTS CAN RESULT IN BODILY INJURY TO THE OPERATOR AND DAMAGE TO THE EQUIPMENT.



**DO NOT PLACE HANDS, TOOLS, OR HOSES IN KETTLE
WHILE AGITATOR IS MOVING**

AGITATOR INSTRUCTIONS

***WARNING* AGITATOR AREA MUST BE CLEAR OF OBSTRUCTION BEFORE OPERATION**

TO RUN AGITATOR

**ENSURE KETTLE IS FULLY UPRIGHT
ENSURE MIXER HEAD IS FULLY DOWN AND LATCHED
SET THE SPEED DIAL TO DESIRED SPEED
TURN THE START SWITCH TO ON**

TO STOP AGITATOR

PRESS THE RED STOP BUTTON OR TURN THE SWITCH TO OFF



**DO NOT PLACE HANDS, TOOLS, OR HOSES IN KETTLE
WHILE AGITATOR IS MOVING**

Table of Contents

IMPORTANT OPERATOR WARNINGS	2
REFERENCES	5
EQUIPMENT DESCRIPTION	6
INSTALLATION AND START-UP	7
OPERATION	7
CLEANING	8
MAINTENANCE	10
TROUBLESHOOTING	11
PARTS LIST	12
ELECTRICAL SCHEMATIC	19
SERVICE LOG	20
WARRANTY	21

References

NATIONAL FIRE PROTECTION ASSOCIATION
60 Battery March Park
Quincy, Massachusetts 02269

NFPA/70 The National Electrical Code

Equipment Description

The Groen TA/3 assembly is an electrically powered mixer with dual counter rotating agitators, which is incorporated into Groen kettles of 40 to 80 gallon capacity.

The main agitator is anchor type and of tubular stainless steel and fitted with scraper fingers. Both the scraper fingers and the agitator assembly are easily removed.

The secondary, counter rotating agitator is constructed of stainless steel and is easily removeable.

The mixer has a variable speed drive with electrical speed control.

For a description of the kettle component of your cooker/mixer, see the separate kettle manual.

Installation and Start-Up



WARNING
TURN OFF POWER AT THE CIRCUIT BREAKER PRIOR TO INSTALLATION.

THE MIXER MUST BE INSTALLED BY PERSONNEL WHO ARE QUALIFIED TO WORK WITH ELECTRICITY. IMPROPER INSTALLATION CAN RESULT IN INJURY TO PERSONNEL AND/OR DAMAGE TO EQUIPMENT.

ANY MECHANICAL OR ELECTRICAL CHANGE MUST BE APPROVED BY THE GROEN FOOD SERVICE ENGINEERING DEPARTMENT.

Your Groen mixer has been test operated at the factory and is furnished with all internal wiring. It is complete and ready for final connection. A wiring diagram is furnished at the rear of this manual.

A. Installation is as follows:

1. Set the cooker/mixer in place and level it. If the mixer is a tilting model, confirm that there is enough rear or side clearance, depending on model, and overhead clearance to tilt the mixer safely through its entire tilting range. Provide enough clearance to permit access for service as well. Fasten the cooker/mixer to the floor or

deck to reduce chances that the unit could tip over if unit is provided with flanged feet.

2. Provide the proper electric power supply as specified on the electrical information plate attached to the mixer. Observe local codes and/or The National Electrical Code in accordance with ANSI/NFPA 70 - latest edition. The installation must conform to the code that has the more strict requirements.
3. Your mixer requires a permanent connection with the electrical service. Use waterproof conduit and waterproof connectors for this connection.
4. Any electrical service for the kettle will require a separate connection. See the specific kettle manual.



WARNING
TO PREVENT POSSIBLE ELECTRIC SHOCK, GROUND THE UNIT AT THE TERMINAL PROVIDED.

5. Use the following check list to confirm that the installation is correct.

Unit level

- Adequate clearance for tilting
- Access for service
- Unit fastened down
- Mixer power supply conforms to information plate and code
- Electrical conduit and connections are waterproof
- Mixer grounded

For instructions on installing the kettle component of your cooker/mixer, see the separate kettle manual.

B. Initial Start-Up

After the mixer is installed, take the following actions to confirm that the equipment is operating correctly.

1. For a tilting model, tilt the mixer through its complete tilting range to ensure that there is no hazard or interference.
2. Make sure the agitator is properly coupled with its drive shaft. The mixer has a slip-on coupling, the drive pin must be positioned at the end of the J-slot. (See photograph 1)
3. Carefully examine the primary agitator to verify that each finger is positioned correctly as shown in figure 1.1.
4. When the mixer is in operating position, each scraper blades should touch the inside of the kettle during at least part of each revolution of the agitator.
5. At the circuit breaker or fuse box, turn on the electric power supply to the mixer.
6. Switch on the drive and confirm that the mixer operates smoothly throughout its speed range.
7. Make sure the agitator turns in the correct direction, so it pushes the nylon scraper blades ahead of the agitator bar.

If the unit functions as described above, it is ready for use. If the unit does not function as intended, call your local Groen authorized service agency.

For instructions on initial start-up of the kettle component of your cooker/mixer, see the separate kettle manual.

WARNING
TURN OFF AGITATOR BEFORE ADDING INGREDIENTS OR INSPECTING KETTLE CONTENTS. DO NOT WEAR LOOSE CLOTHING OR JEWELRY AROUND OPERATING MIXER KETTLE. KEEP WELL CLEAR OF ROTATING MIXER ARMS AND PADDLES AT ALL TIMES.

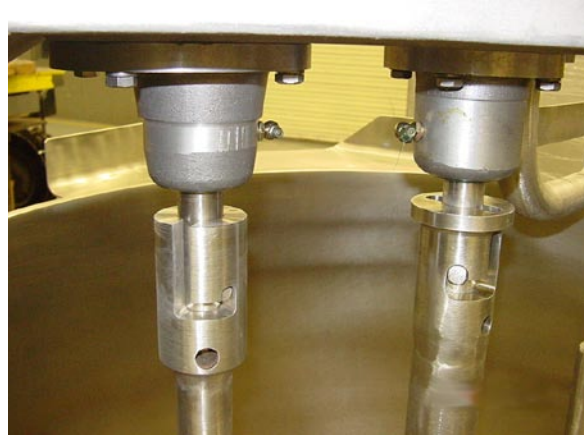

Photo 1: Slip-on Coupling

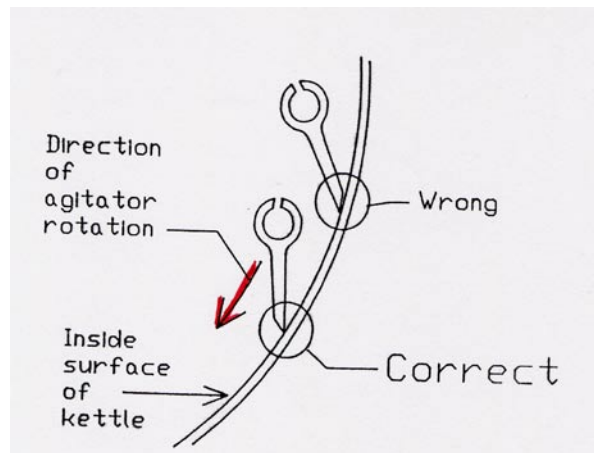

Figure 1.1

Operation

WARNING

TURN OFF AGITATOR BEFORE ADDING INGREDIENTS OR INSPECTING KETTLE CONTENTS. DO NOT WEAR LOOSE CLOTHING OR JEWELRY AROUND OPERATING MIXER KETTLE. KEEP WELL CLEAR OF ROTATING MIXER ARMS AND PADDLES AT ALL TIMES.

- Before you operate the mixer, make sure that the agitator is firmly connected with the drive shaft and properly positioned in the kettle. The agitator must be positioned so every scraper blade touches the kettle during at least part of each revolution. To connect the agitator:
 - Slip-on Coupling: Slide the coupling up onto the shaft as far as it will go. Then turn the agitator and pull it down, so that the drive pin on the shaft becomes firmly seated against the end of the J-slot.
 - Bolted Coupling:
 - Guide the two pins of the drive shaft into the holes in the coupling.
 - With the lobe of the cam pointing up**, and while holding the two cam bolts, insert the bolts through the larger holes in the side of the coupling. The bolts must pass the flat part of the shaft, and through the smaller holes in the other side of the coupling.
 - Turn the cam bolts toward the shaft 1/8 turn or until the lobe of the cam is snug against the flat side of the shaft.
 - Fasten the bolts in place with the supplied hex nuts, and tighten the nuts.
- If the mixer has been tilted up, lower it into operating position.

WARNING
THE UNIT IS EQUIPPED WITH AN AUTOMATIC TILT CUTOFF SWITCH. IF POWER IS ON WHEN A TILTED MIXER IS LOWERED INTO OPERATING POSITION, THE MIXER WILL AUTOMATICALLY START.

- Turn on electric power to the unit at the circuit breaker or fuse box.
- Switch on the drive.

- Set the desired mixing speed.

CAUTION

STARTING WITH THE MIXER SET AT HIGH SPEED MAY CAUSE MATERIAL TO SPILL OUT OF THE KETTLE ON VARIABLE SPEED UNITS.

- On a variable speed drive with electrical speed control, turn the speed adjustment knob.

CAUTION

UNDER HEAVY LOAD DO NOT RUN THE MIXER CONTINUOUSLY AT SLOWER THAN 5% OF FULL SPEED. SLOWER OPERATION COULD DAMAGE THE SPEED CONTROL.

- To stop the mixer, switch off the drive. If the cooker/mixer will be cleaned or serviced, or will not be used for a week or longer, cut off all power supplies to the unit at the circuit breaker or fuse box.
- Switch off the drive, before you tilt the mixer. To tilt the mixer, first unlatch it (See Photograph). For some units, you may need to tilt the kettle forward slightly to let the agitator clear the kettle wall as you tilt the mixer.
- As you tilt the mixer out of the kettle, clean any clinging product from the agitator, so product will not drip onto the outside of the kettle or surroundings, and so the weight of product will not make the mixer fall down.

To operate the kettle component of your cooker/mixer, see the separate kettle manual.

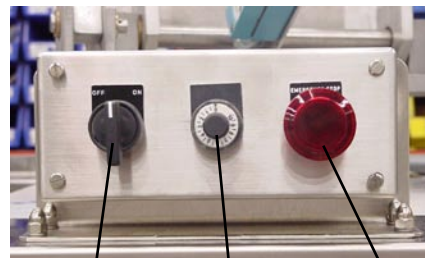

ON/OFF Switch 3 Speed Control Knob Emergency Stop Switch

Cleaning

A. Suggested Tools & Materials.

1. A good stainless steel cleaner.
2. Stiff brush.
3. Sanitizer Solution

B. Precautions



WARNING
BEFORE CLEANING ANY PART OF THE MIXER, OTHER THAN THE AGITATOR, SHUT OFF ALL ELECTRIC POWER TO THE COOKER/MIXER AT THE CIRCUIT BREAKER OR FUSE BOX, TO AVOID POSSIBLE ELECTRIC SHOCK.

KEEP WATER AND SOLUTIONS OUT OF THE CONTROLS, ELECTRICAL WIRING, AND DRIVE MECHANISM. NEVER SPRAY OR HOSE THE MIXER.

C. Procedure

1. Wash the agitator as soon as possible after use. If the unit is in continuous use, thoroughly clean and sanitize all parts of the mixer at least once every 12 hours
2. Disassemble the scrapers and clean them along with the rest of the agitator, then reassemble them. To disassemble a scraper:
 - a. Decouple both agitators from the drive shafts. (see photo1 on page 7). Just lift the agitator and rotate it in the "J" slot to decouple.
 - b. Lay both agitators on flat surface (Photo 2)
 - c. Remove hairpin clip from agitator (Photo 3)
 - d. Remove scraper blades.
 - e. Reverse procedure to assemble. CAUTION - verify that the scraper blade is assembled correctly. (See figure 1.1 on page 7)



Photo 2



Photo 3

CAUTION

WHEN YOU CONNECT THE SCRAPER WITH THE YOKE, MAKE SURE THE SCRAPER IS CURVED THE SAME WAY AS THE KETTLE. A REVERSED SCRAPER WILL NOT SCRAPE AND CAN CAUSE SERIOUS DAMAGE.

WARNING

AVOID CONTACT WITH ANY CLEANER, AS RECOMMENDED BY THE SUPPLIER. CAREFULLY READ THE WARNINGS AND FOLLOW THE DIRECTIONS ON THE LABEL OF THE CLEANER. MANY CLEANERS ARE HARMFUL TO THE SKIN, EYES, MUCOUS MEMBRANES, AND CLOTHING.

3. Prepare a hot solution of the cleaning compound as instructed by the supplier. Wash the agitator parts and rinse them well. Use a cloth moistened with the cleaning solution to clean other parts of the mixer.
4. To remove materials stuck to the agitator, use a brush, sponge, cloth, plastic or rubber scraper, or plastic wool along with the cleaning solution. To make washing easier, let the cleaning solution soak into the residue. When you clean the stainless steel parts, do **not** use any abrasive material (like metal sponges or scouring powder) or metal implement (like a spoon, scraper, or wire brush) that might scratch the surface. Scratches make the surface hard to clean and provide places for bacteria to grow. Do **not** use steel wool, which may leave particles imbedded in the surface and cause eventual corrosion and pitting.
5. As part of the daily cleaning program, clean all surfaces that may have been soiled. Remember to check such parts as the back and underside of the drive housing.
6. When the agitator needs to be sanitized, use a sanitizing solution equivalent to one that supplies 100 parts per million available chlorine. Obtain advice on the best sanitizing

agent from your supplier of sanitation products. Following the supplier's directions, apply the sanitizer after the agitator has been washed, then rinse off the sanitizer completely. It is recommended that the agitator be sanitized just before use.

CAUTION

NEVER LEAVE A SANITIZER IN CONTACT WITH THE SURFACE OF STAINLESS STEEL LONGER THAN 20 MINUTES. LONGER CONTACT CAN CAUSE CORROSION.

7. The exterior of the unit may be polished with a good quality stainless steel cleaner.

Cleaning procedures for the kettle component of your cooker/mixer are described in the separate kettle manual.

Maintenance

WARNING
USE OF ANY REPLACEMENT PARTS OTHER THAN THOSE SUPPLIED BY GROEN OR THEIR AUTHORIZED DISTRIBUTOR VOIDS ALL WARRANTIES AND CAN CAUSE BODILY INJURY TO THE OPERATOR AND DAMAGE TO THE EQUIPMENT.

SERVICE PERFORMED BY OTHER THAN FACTORY AUTHORIZED PERSONNEL WILL VOID ALL WARRANTIES.

A. Periodic Service

1. The interior of control and drive housings should be kept clean and dry.
2. Electrical wiring should be kept securely connected and in good condition.
3. Regular service of the mixer should include cleaning the motor and checking the reducer gearcase. Check oil level at 3000hrs of operation or every 6 months. Change oil completely every 3 years or every 15,000 hours. Lubricant type is GG Artic SHC 23" Food grade lubricant (Mobil product)
4. Every six(6) months lubricate all grease fittings on the transfer case with a USDA approved food grade grease/lubricant. Wipe off excess lubricant.

B. Component Replacement

WARNING
BEFORE REPLACING ANY PARTS, SHUT OFF ALL ELECTRIC POWER SUPPLIES TO THE COOKER/MIXER.

All internal wiring is marked as shown on the schematic drawings in this manual. Be sure that new components are wired in the same manner as the old components.

C. Service Records

A Service Log is provided At the rear of this manual. Each time service is performed on this equipment, enter the date on which the work was done, what was done, and who did it. Keep this log with the equipment.

Service procedures for the kettle component of the cooker/mixer are described in the separate kettle manual.

Troubleshooting

Your Groen Mixer will operate smoothly and efficiently if properly maintained. However, the following is a list of checks to make in the event of a problem. If the actions suggested do not solve the problem, call your authorized Groen Service Representative. For the phone number of the nearest agency, check the Groen web site at www.groen.com, ask your area Groen representative or call the Groen Parts and Service Department. If an item on the list is followed by X, the work should only be performed by a qualified service representative.

WARNING		
USE OF ANY REPLACEMENT PARTS OTHER THAN THOSE SUPPLIED BY GROEN OR THEIR AUTHORIZED DISTRIBUTORS CAN CAUSE INJURY TO THE OPERATOR AND DAMAGE TO THE EQUIPMENT AND WILL VOID ALL WARRANTIES.		
SERVICE PERFORMED BY OTHER THAN FACTORY-AUTHORIZED PERSONNEL WILL VOID ALL WARRANTIES.		
SYMPTOM	WHO	WHAT TO CHECK
		X indicates items which must be performed by an authorized technician.
Motor will not run.	User	a. Power supply to the unit. b. For a mechanical overload. (example: frozen product) c. Circuit breaker or fuse.
	Auth Service Rep Only	d. That the tilt switch is closed. X e. For a ground or short in the motor. X f. Overload heaters. X
Motor runs slowly.	User	a. For a mechanical overload.
	Auth Service Rep Only	b. For open motor field circuit, by checking field current. X
Motor speed varies rapidly.	User	a. For an oscillating load, by disconnecting the mixer drive from the agitator and checking motor speed.
	Auth Service Rep Only	b. Variable speed controller X
Motor overheats and/or sparks excessively.	User	a. For a mechanical overload. b. Ambient temperature is high.
	Auth Service Rep Only	c. Incorrect supply voltage to motor. X d. Excessive variation (under voltage or over voltage) in supply voltage. X e. Single phasing due to loose connection in supply line or a blown fuse. X
Circuit breaker or heater cuts out frequently.	User	a. For a mechanical overload.
	Auth Service Rep Only	b. Whether line voltage is too high. X c. Motor armature and wiring for ground or short. X d. For open motor field circuit, by checking field current. X e. For defective circuit breaker. X f. Motor improperly connected. X

Troubleshooting guidance for the kettle component of your cooker/mixer is contained in the separate kettle manual.

Parts List

To order parts, contact your authorized Groen Service Agency. Supply the model designation, part description, part number and quantity required. Where applicable, provide the voltage and phase as well.

WARNING
USE ONLY GROEN-SUPPLIED PARTS. SUBSTITUTION OF UNAUTHORIZED OR GENERIC PARTS CAN RESULT IN BODILY INJURY TO THE OPERATOR AND DAMAGE TO THE EQUIPMENT.

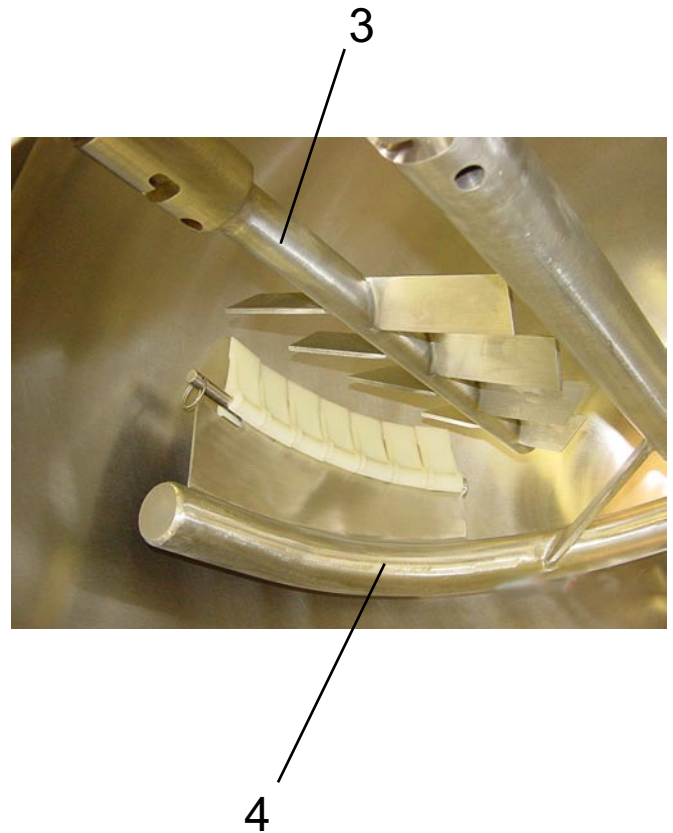
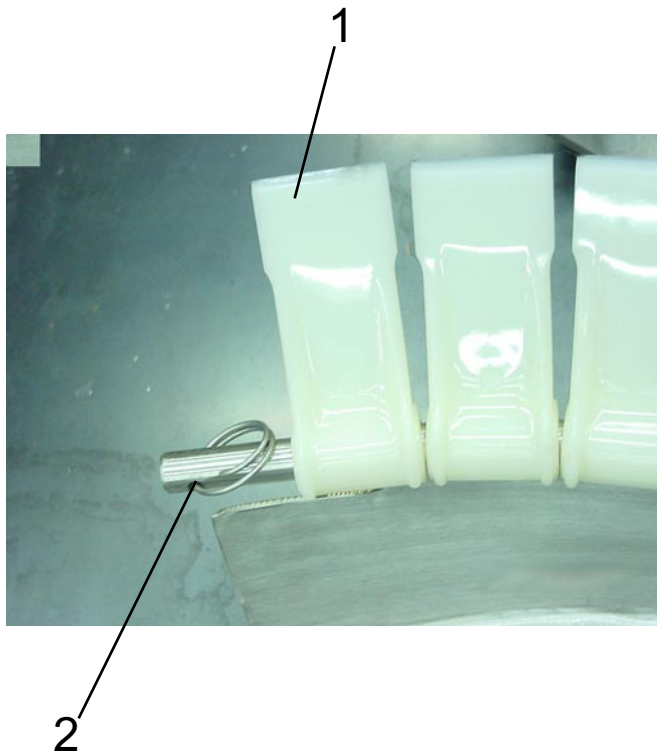

Diagram No.	Description	Part No.
1	Scraper Blade	006502
2	Hairpin Clip	012947
3	Agitator Secondary	009686 - 40 Gallon 009687 - 60 Gallon 009688 - 80 Gallon
4	Primary Agitator Assy.	009243 - 40 Gallon 009244 - 60 Gallon 009245 - 80 Gallon

Parts List

Description	Part No.	Description	Part No.
Switch Assembly Agitator	128485	Handle & Latch Assy	044392
Switch Assembly Speed Control	115341	Bracket Arm Guide	002124
Switch Assembly Emergency Stop	115342	Pin Taper #4 2" Long	005474
Enclosure Nema	128458	Snubber	009122
Enclosure , 12" x 16" x8"	128460	Handle & Bracket Assy	009238
Inverter 230 Vac	120436	Knob Red Ball Handle	012691
Inverter 380/460V	128975	Power Aid Assy	009718
Terminal Block 3 - Pole	003888	Pin Poweraid Connection Top	012889
Contactora 12Amp 4 Pole	111072	Pin Poweraid Connection	012890
Fuse Block	096809	Plate Mounting	002153
Fuse 20 Amp	071489	Base Pivot and Poweraid Assy	128618
Transformer, 100 Va	115356	Agitator Primary 40 Gal	009243
Lug, Ground 14-6 AWG	119829	Agitator Secondary 40 Gal	009686
Wiring Kit, Variable Speed	132383	Blade Fixed Scraper	001864
Relay, Control	115358	Scraper Finger Blade	006502
Socket Relay	115359	Holder Assy Scraper Top 40 Gal	010548
Wiring Schematic Variable	128491	Holder Assy Scraper Bottom 40 Gal	010549
Wiring Harness	128482	Holder Scraper Blade	001721
Wiring Harness Control Box	128483	Clip Hairpin Tri-Cover	012947
Wiring Harness Control Box to Agitator	128484	Coupling Quick Disconnect	009304
Fuse Block (Type M) 3 Pole	120706	Coupling Quick	009239
Cover Agitator Tilt	006972	Drive 1.5 HP, 208/360V	135822
Cover Inside Agitator	006973	Drive 2.0 HP, 240/480V	128979
Bearing Roller	009212	Drive 1.5 HP, 240/480V	135578
Shaft 3/4" Dia x 7-5/8" Long	009694	Drive 2.0 HP, 208/360V	132099
Transfer Case Casting	019640	Mounting Plate	128519
Cover Transfer Case	009608	Bracket Assy	128516
Gasket 5/32" x 1/2"	012323	Gasket 5/32" x 1/2" x 50' Vertical Strip	002121
Cover Transfer Case, Rear	132037	Gasket 5/32" x 1/2" x 50' w/ Adhesive	005233
Mercury Tilt Switch	127408	Seal Cover Plate	006975
Bracket For Tilt Switch	128408	Base Pivot & Power Aid Assy	003662
Front Transfer Case Assy,	135336	Power Aid Assy	009719
Housing Front Bearing	009203	Bearing Cylindrical	009722
Housing Eccentric Bearing	009204	Bearing Cylindrical	009724
Housing Top Bearing	009205	Pin Power Aid Connection Top	012889
Washer Thrust	009208	Ring Basic External	001538
Bearing Cylindrical	009209	Shaft 3/4" Dia x 7-5/8" Long	009694
Ring External	009223	Transfer Case Glass Bead	019641
Pin Coupling 3/8" DIA	009253	Shaft Seal	001758
Key 1/4" Square x 2" Long	009258	Plate, Gearmotor Adaptor	128989
Shaft 1" x 11 - 1/2" Long	009557	Gear Pinion	009254
Gear Pinion	009268	Gear Spur	009260
Gear Spur	009269	Shaft Extender	132026
Pin Coupling	009305	Handle & Latch	041015
Key 1/4" Square x 1-1/2" Long	009249	Handle & Bracket	009185
Shaft, Motor for 135115	135117	Handle & Spring	009181
Set Collar	012012	Fitting Grease #70	012100
Plate, Motor & Drive Gear Assy	135119	Cover Plate	128379
Screw, Socket Cap Grade 8	115302	Agitator Primary 60 Gal	009244
		Holder Assy Scraper 60 Gal	010554

Parts List

Description	Part No.	Description	Part No.
Holder Scraper Blade	001724	Holder Assy Scraper 80 Gal	010561
Holder Assy Scraper 60 Gal	010557	Holder Assy Scraper 80 Gal	010563
Agitator Secondary 60 Gal	009687	Clip Hairpin	012947
Agitator Primary 80 Gal	009245		
Agitator Secondary 80 Gal	009688		

FRONT SECTION ASSEMBLY - 40 GALLON KETTLES

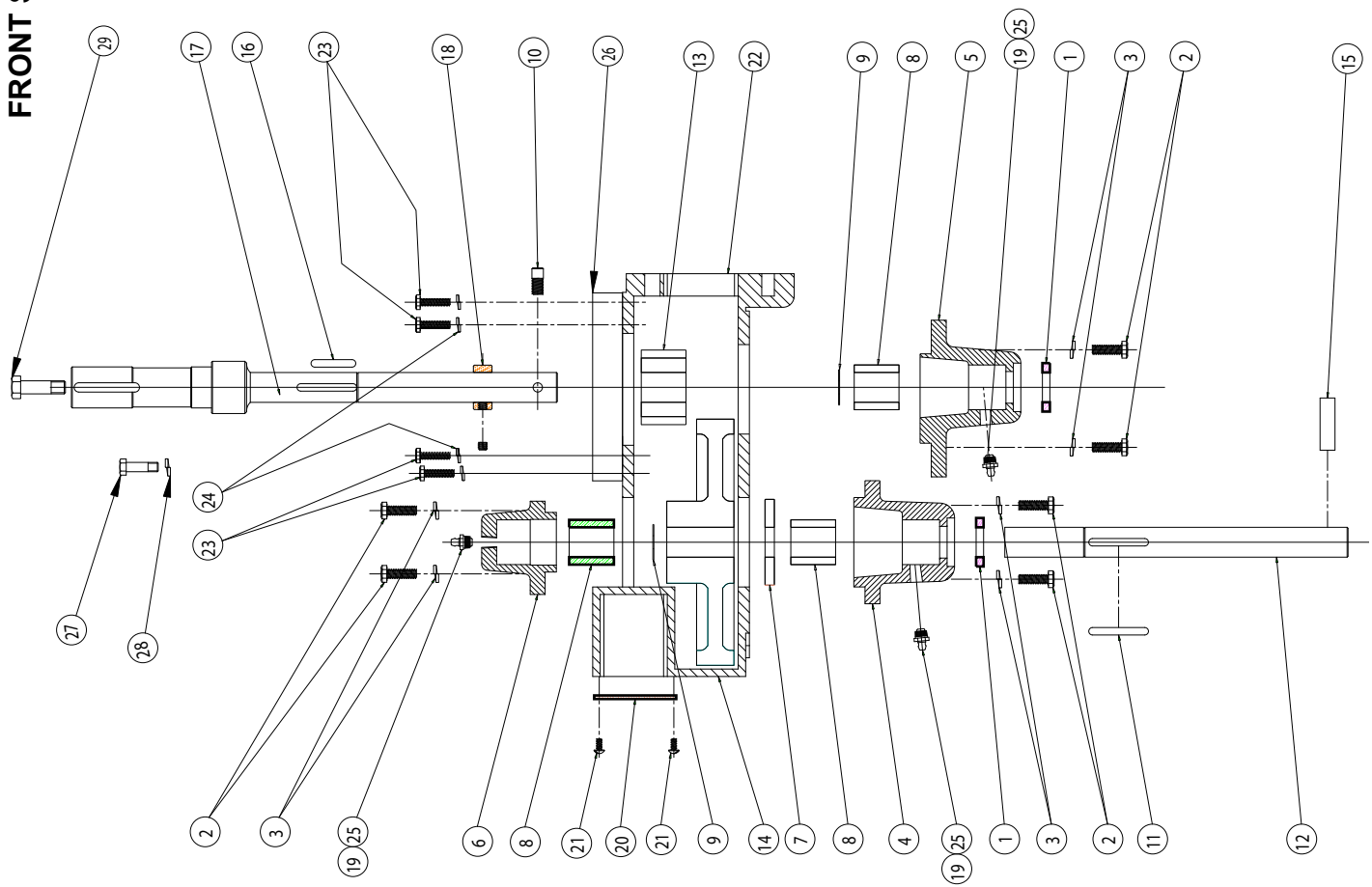

ITEM NO.	QTY REQD	PART OR IDENTIFYING NO.	NOMENCLATURE OR DESCRIPTION
29	1	006029	SCREW HEX HD CAP 7/16" - 14 X 1 1/2" LG
28	4	014830	LOCKWASHER, 7/16" DIA
27	4	115302	SCREW, SOCKET CAP GRADE 8 5/16"-18 X 1 1/2" LG
26	1	135118	SPACING PLATE, MOTOR & DRIVE GEAR ASSY, EURODRIVE
24	4	005655	LOCKWASHER, 1/4"
23	4	005610	BOLT, 1/4"-20 X 1/2" LONG
22	REF.	009263	FRONT HOUSING, TRANSFER CASE
21	4	006009	SCREW, ROUND HEAD, #10-32 X 3/8" LONG
20	1	128379	COVER PLATE, SWITCH
19	3	012100	FITTING GREASE, STRAIGHT
18	1	012012	SET, COLLAR 1" ID
17	1	135117	SHAFT, MOTOR DRIVE
16	1	009249	KEY, 1/4" SQ. X 1-1/2" LONG
15	1	009305	PIN, COUPLING 1/2" DIA
14	1	009269	GEAR SPUR, 64-TEETH
13	1	009268	GEAR, PINION (24) TEETH
12	1	009557	SHAFT, 1" DIA. X 11-1/2" LG.
11	1	009258	KEY, 1/4" SQ. X 2" LG. ROUND ENDS
10	1	009253	PIN, COUPLING 3/8" DIA
9	2	009223	RING, EXTERNAL
8	3	009209	BEARING, CYLINDRICAL
7	1	009208	WASHER THRUST, 1"
6	1	009205	HOUSING, TOP BEARING
5	1	009204	HOUSING, ECCENTRIC
4	1	009203	HOUSING, FRONT BEARING
3	12	005656	WASHER LOCK, 5/16"
2	12	005613	SCREW, HEX HEAD CAP, 5-16"-18 X 1" LONG
1	2	001758	SEAL, SHAFT
			NOMENCLATURE OR DESCRIPTION

TRANSFER CASE ASSEMBLY - 40 GALLON UNITS

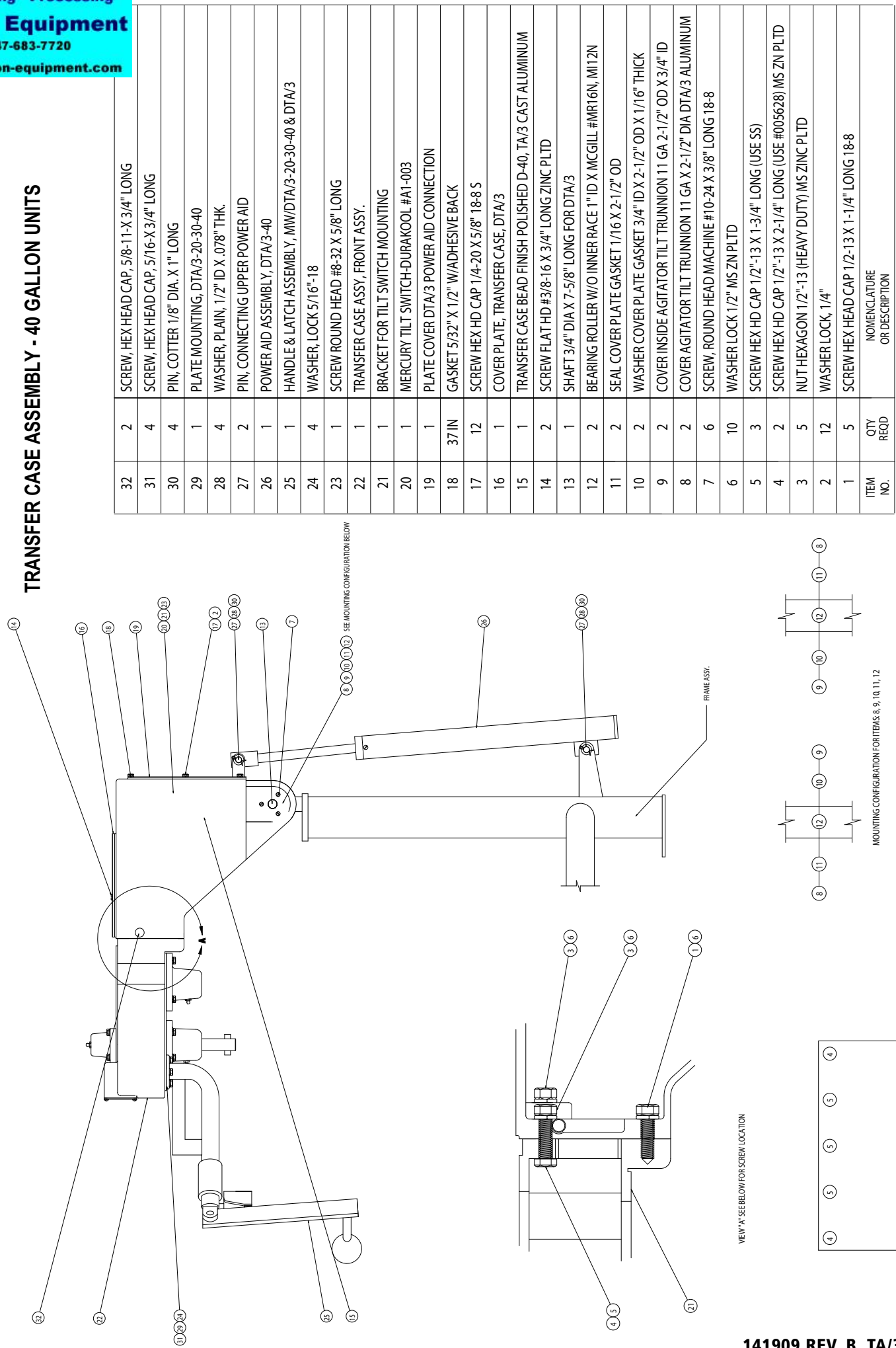

ITEM NO.	QTY REQD	NOMENCLATURE OR DESCRIPTION
32	2	SCREW, HEX HEAD CAP, 5/8-11-X 3/4" LONG
31	4	SCREW, HEX HEAD CAP, 5/16-X 3/4" LONG
30	4	PIN, COTTER 1/8" DIA. X 1" LONG
29	1	PLATE MOUNTING, DTA/3-20-30-40
28	4	WASHER, PLAIN, 1/2" ID X .078" THK.
27	2	PIN, CONNECTING UPPER POWER AID
26	1	POWER AID ASSEMBLY, DTA/3-40
25	1	HANDLE & LATCH ASSEMBLY, MM/DTA/3-20-30-40 & DTA/3
24	4	WASHER, LOCK 5/16"-18
23	1	SCREW ROUND HEAD #8-32 X 5/8" LONG
22	1	TRANSFER CASE ASSY, FRONT ASSY.
21	1	BRACKET FOR TILT SWITCH MOUNTING
20	1	MERCURY TILT SWITCH-DURAKOOL #A1-003
19	1	PLATE COVER DTA/3 POWER AID CONNECTION
18	37/IN	GASKET 5/32" X 1/2" W/ADHESIVE BACK
17	12	SCREW HEX HD CAP 1/4-20 X 5/8" 18-8 S
16	1	COVER PLATE, TRANSFER CASE, DTA/3
15	1	TRANSFER CASE BEAD FINISH POLISHED D-40, TA/3 CAST ALUMINUM
14	2	SCREW FLAT HD #3/8-16 X 3/4" LONG ZINC PLTD
13	1	SHAFT 3/4" DIA X 7-5/8" LONG FOR DTA/3
12	2	BEARING ROLLER W/O INNER RACE 1" ID X MCGILL #MR16N, MI12N
11	2	SEAL COVER PLATE GASKET 1/16 X 2-1/2" OD
10	2	WASHER COVER PLATE GASKET 3/4" ID X 2-1/2" OD X 1/16" THICK
9	2	COVER INSIDE AGITATOR TILT TRUNNION 11 GA 2-1/2" OD X 3/4" ID
8	2	COVER AGITATOR TILT TRUNNION 11 GA X 2-1/2" DIA DTA/3 ALUMINUM
7	6	SCREW, ROUND HEAD MACHINE #10-24 X 3/8" LONG 18-8
6	10	WASHER LOCK 1/2" MS ZN PLTD
5	3	SCREW HEX HD CAP 1/2"-13 X 1-3/4" LONG (USE SS)
4	2	SCREW HEX HD CAP 1/2"-13 X 2-1/4" LONG (USE #005628) MS ZN PLTD
3	5	NUT HEXAGON 1/2"-13 (HEAVY DUTY) MS ZINC PLTD
2	12	WASHER LOCK, 1/4"
1	5	SCREW HEX HEAD CAP 1/2-13 X 1-1/4" LONG 18-8
		NOMENCLATURE OR DESCRIPTION

PARTS LIST

VIEW 'A' SEE BELOW FOR SCREW LOCATION

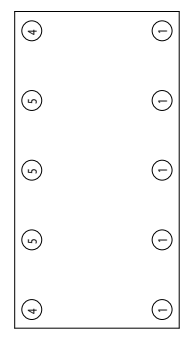

SCREW LOCATION

MOUNTING CONFIGURATION FOR ITEMS 8, 9, 10, 11, 12

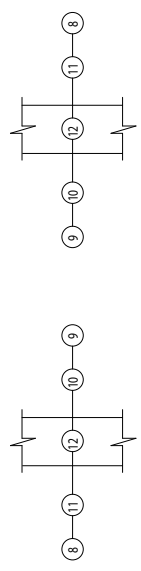

TRANSFER CASE ASSEMBLY 60 & 80 GALLON

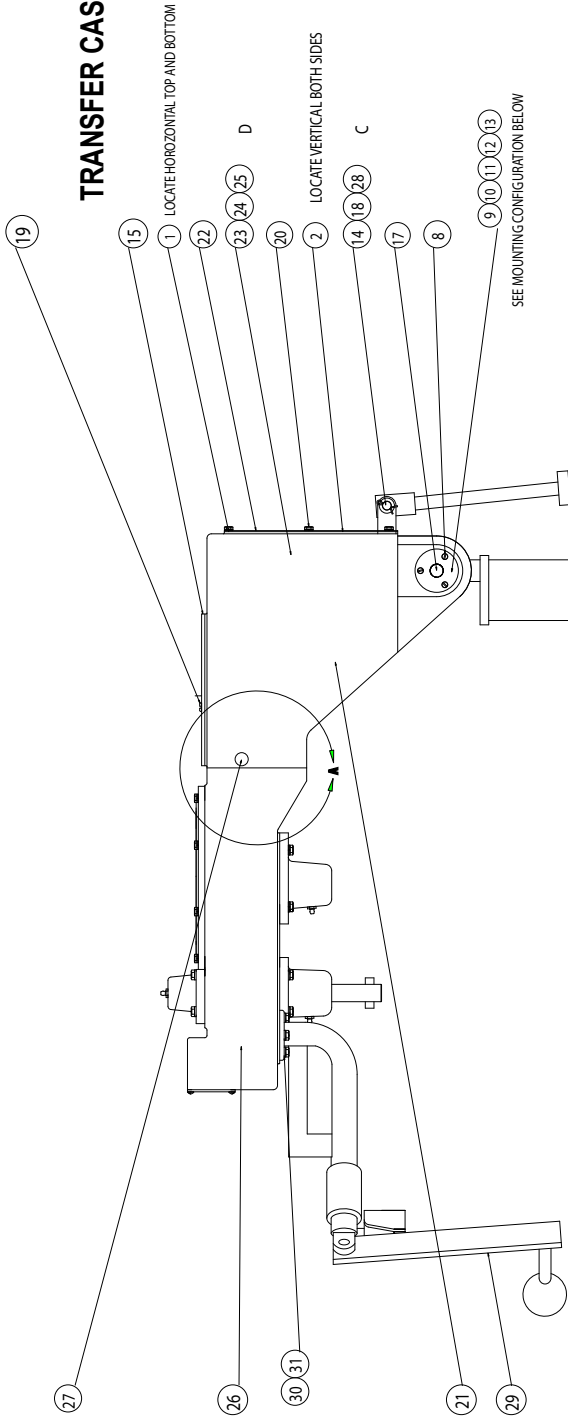

SEE MOUNTING CONFIGURATION BELOW

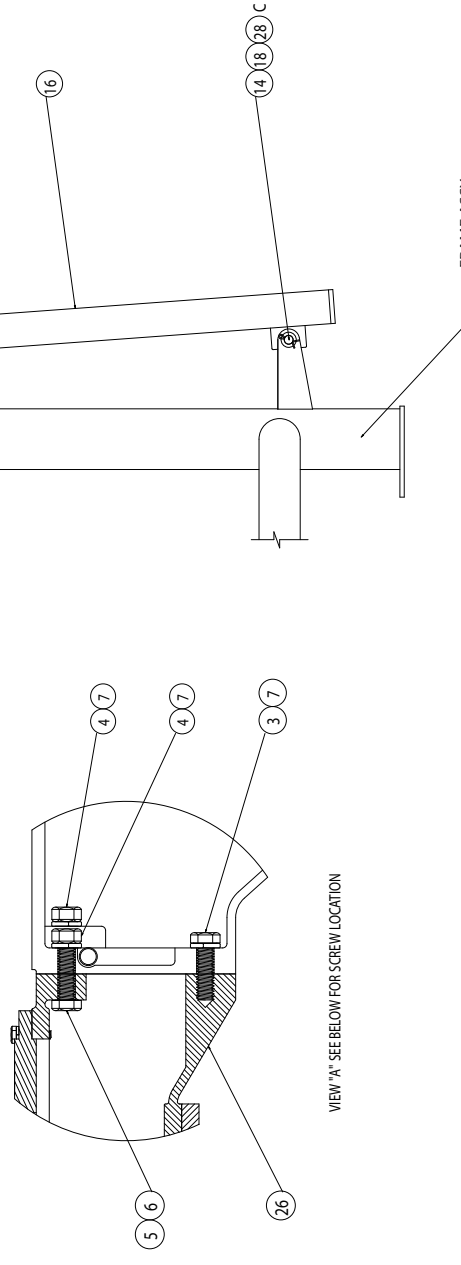

VIEW "A" SEE BELOW FOR SCREW LOCATION

FRAME ASSY.

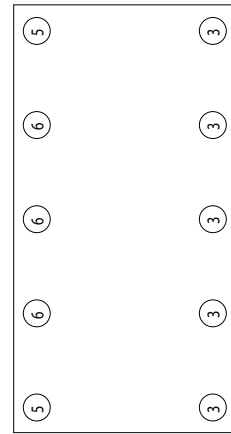

SCREW LOCATION

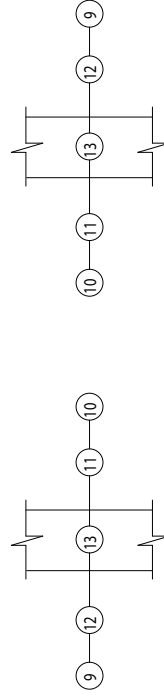

MOUNTING CONFIGURATION FOR ITEMS: 9, 10, 11, 12, 13

ITEM NO.	QTY	PART OR IDENTIFYING NO.	NUMBER OR DESCRIPTION
31	4	005656	WASHER, LOCK 5/16" 18-8
30	4	005613	SCREW, HEXAGON HEAD CAP 5/16-18 X 1" LONG 18-8
29	1	041015	HANDLE & LATCH ASSY DTA & MN/DTA/3-60
28	4	005598	WASHER PLAIN 1/2" ID X .078" THICK FITS 1/2" 18-8
27	2	009878	SCREW HEX HEAD CAP 5/8"-11 X 3/8" LONG
26	1	128999	TRANSFER CASE ASSY (60 Gallon) ; (80 Gallon)
25	1	007526	SCREW ROUND HEAD MACHINE #8-32 X 5/8" LONG MS ZN PLD
24	1	128408	BRACKET FOR TILT SWITCH MOUNTING
23	1	122176	MERCURY TILT SWITCH-DURAKOOL #A1-003
22	1	013873	PLATE COVER/POWERAID CONNECTION DTA/3-40-60-80
21	1	019641	TRANSFER CASE BEAD FINISH POLISHED DTA/3-60-80 CAST ALUMINUM
20	12	078546	SCREW HEX HD CAP 1/4-20 X 5/8" 18-8 S
19	2	013466	SCREW FLAT HD #3/8-16 X 3/4" LONG ZINC PLTD
18	2	013405	PIN CONNECTION UPPER POWERAID 1/2" DIA. X 2-3/8" LONG DTA
17	1	009694	SHAFT 3/4" DIA X 7-5/8" LONG FOR DTA/3
16	1	012903	POWERAID ASSY, DTA/3-60
15	1	132037	PLATE COVER DTA/3 W/O ELECTRICAL HOLE
14	4	009246	PIN COTTER 1/8" DIA. X 1" LONG
13	4	009212	BEARING ROLLER W/O INNER RACE 1" ID X MCGILL #MR16N, M17.2N
12	2	006975	SEAL COVER PLATE GASKET 1/16 X 2-1/2 OD
11	2	006974	WASHER COVER PLATE GASKET 3/4" ID X 2-1/2" OD X 1/16" THICK
10	2	006973	COVER INSIDE AGITATOR TILT TRUNNION 11 GA 2-1/2" OD X 3/4" ID
9	2	006972	COVER AGITATOR TILT TRUNNION 11 GA X 2-1/2" DIA DTA/3 ALUMINUM
8	6	006009	SCREW ROUND HEAD MACHINE #10-24 X 3/8" LONG 18-8
7	10	005735	WASHER LOCK 1/2" MS ZN PLD
6	3	005734	SCREW HEX HD CAP 1/2"-13 X 1-3/4" LONG (USE SS)
5	2	005728	SCREW HEX HD CAP 1/2"-13 X 2-1/4" LONG (USE #005628) MS ZN PLTD
4	5	005705	NUT HEXAGON 1/2"-13 (HEAVY DUTY) MS ZINC PL
3	5	005623	SCREW HEX HEAD CAP 1/2-13 X 1-1/4" LONG 18-8
2	2	005233	GASKET 5/32" X 1/2" X 8" LONG W/ADHESIVE BACK
1	2	002121	GASKET 5/32" X 1/2" X 10-1/8" VERTICAL STRIP W/ADHESIVE BACK

PARTS LIST

Electrical Schematics

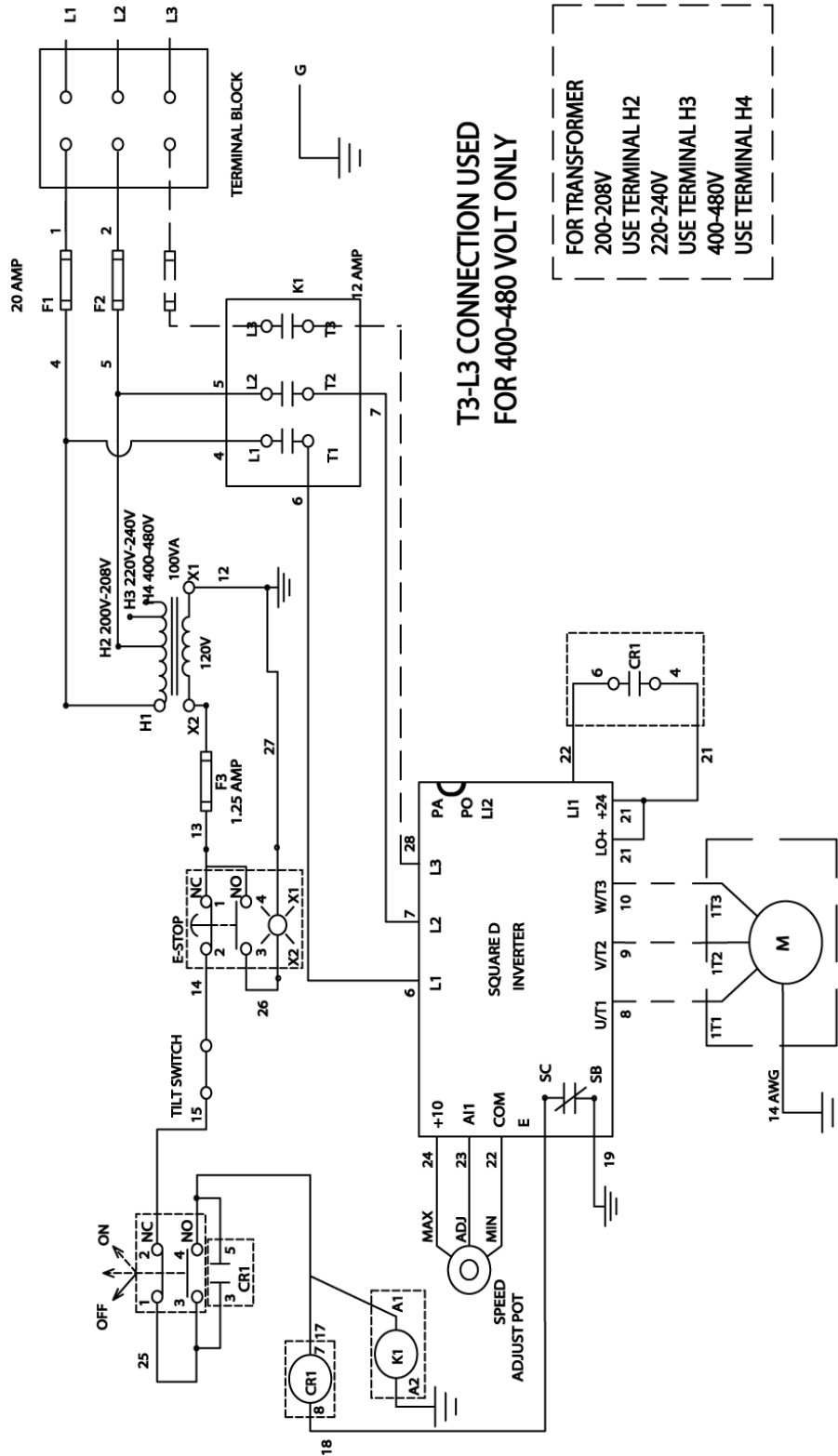

**T3-L3 CONNECTION USED
 FOR 400-480 VOLT ONLY**

FOR TRANSFORMER
 200-208V USE TERMINAL H2
 220-240V USE TERMINAL H3
 400-480V USE TERMINAL H4

P/N 128491
 REV. B